



**National Highways Authority of India  
(Ministry of Road Transport & Highways)  
Government of India**

**Consultancy Services for Preparation of Feasibility Study and Detailed Project Report for:-**

- (i) 4-lane Elevated Section at Begusarai at Chainage 221.910 to 224.935 on NH-31, Length 3.025 Km
- (ii) 4-lane Elevated section of Shivala - Bihta section of Patna - Koilwar on NH-30 at design Chainage 16.050 to 29.500 of proposed alignment of NH-30, Length 13.450 Km
- (iii) 4-lane Elevated section at Gopalganj Chainage 384.483 to 386.362 on NH-28, Length 1.879 Km.

***REQUEST FOR PROPOSAL (RFP)***

**December, 2017**

**G-5&6, Sector-10, Dwarka-New Delhi-110075**

## INDEX

Sl. No.	Content	Page No.
1	Notice Inviting Tender (NIT)	3
2	Letter of Invitation	4-18
3	Annex -I : Details of the Proposed Stretch	19
4	Annex-II : Procedure of Assessment of Least Cost to NHAI under special circumstances	20-25
5	Data Sheet	26-35
6	Appendix - I : Terms of Reference	36-105
7	Supplement -I: Additional Requirements for Hill Roads	106-110
8	Supplement - II: Additional Requirements for Bridges	111-113
9	Supplement – III : Additional requirement for safety audit	114-118
10	Enclosure - I : Manning Schedule	119-120
11	Enclosure - II : Qualification Requirements of Key Personnel	121-130
12	Enclosure - III: Schedule for Submission of Reports and Documents and format of submission of reports and documents.	131-133
13	Enclosure - IV: Format for submission of reports and documents	134-138
14	Appendix – II : Formats for Eligibility	139-145
15	Appendix - III : Formats for Technical Proposals	146-156
16	Appendix - IV: Formats for Financial Proposals	157-166
17	Appendix - V: Detailed Evaluation Criteria	167-186
18	Appendix - VI: Draft Contract Agreement	187-231
19	Appendix – VII: DPR Checklist for 8 stages [Stage 1: Inception Report, Stage 2: Feasibility Report, Stage 3: LA & Clearances I, Stage 4: Detailed Project Report, Stage 5: Technical Schedules, Stage 6: LA & Clearances II]: Stage 7: Award Determination(Structures), Stage 8: Land Possession Report (Structures)	232-271
20	Appendix- VIII: Sample Executive Summary of Detailed Project Report	272-301

**National Highways Authority of India (NHAI)  
(Ministry of Road Transport and Highways)  
Government of India**

**NOTICE INVITING TENDER (NIT)**

NHAI/BH/Elevated/DPR/2017/Proc.

Date:-26.12.2017

1. NHAI has been assigned the work of **Consultancy Services for Preparation of Feasibility Study and Detailed Project Report for:-**

- (i) 4-lane Elevated Section at Begusarai at Chainage 221.910 to 224.935 on NH-31, Length 3.025 Km
- (ii) 4-lane Elevated section of Shivala - Bihta section of Patna - Koilwar on NH-30 at design Chainage 16.050 to 29.500 of proposed alignment of NH-30, Length 13.450 Km
- (iii) 4-lane Elevated section at Gopalganj Chainage 384.483 to 386.362 on NH-28, Length 1.879 Km.

(as per Annexure I).

- 2. Proposals are hereby invited from eligible Consultants for preparation of Detailed Project Report of <Project Description>. The Letter of Invitation (LOI) and Terms of Reference (ToR) including Request for Proposal (RFP) is available online on e-tender portal of <https://etenders.gov.in>. The document can also be downloaded from NHAI website ([www.nhai.org](http://www.nhai.org)). Cost of the Document in the form of a Non-refundable document fee of Rs.5,000 (Rupees Five Thousand only) in the form of Demand Draft favoring 'National Highways Authority of India' and payable at New Delhi must be furnished in a separate envelop while submitting the proposal.
- 3. The RFP has also been uploaded on "INFRACON" ([www.infracon.nic.in](http://www.infracon.nic.in)). As such before submitting the proposal the Consultant shall mandatorily register and enlist themselves (the firm and all key personnel), on the MoRTH portal "INFRACON" and furnish registration details along with its RFP. A copy of Infracon Operation Procedure is also enclosed for bidder's reference.
- 4. All the bidders registered on Infracon shall form a Team on Infracon and which would be assigned unique Infracon Team ID. Bidders while submitting the proposal shall quote the Infracon Team ID.
- 5. Bid must be submitted online at e-tender portal of NHAI <https://etenders.gov.in> on or before <Time, **24.01.2018**>.

6. The following schedule is to be followed for this assignment:

- i) Deadline for downloading of bid: <1100 hrs, 24.01.2018>
- ii) Last date for submission of queries: <1500 Hrs, 10.01.2018>
- iii) Pre bid meeting: <1500 hrs, 10.01.2018>
- iv) Deadline for Physical Submission of bids : <1100 hrs, 25.01.2018>

Yours sincerely,

S. S. Jha  
General Manager (Tech.) Bihar  
National Highways Authority of India  
G-5&6, Sector 10, Dwarka,  
New Delhi-110075  
E-mail: [sheoshankar@nhai.org](mailto:sheoshankar@nhai.org)  
Website: [www.nhai.org](http://www.nhai.org)

## Letter of Invitation (LOI)

<Reference>

Dated:

<Date>

Dear Sir,

### **Sub: Consultancy Services for Preparation of Feasibility Study and Detailed Project Report for:-**

- (i) 4-lane Elevated Section at Begusarai at Chainage 221.910 to 224.935 on NH-31, Length 3.025 Km
- (ii) 4-lane Elevated section of Shivala - Bihta section of Patna - Koilwar on NH-30 at design Chainage 16.050 to 29.500 of proposed alignment of NH-30, Length 13.450 Km
- (iii) 4-lane Elevated section at Gopalganj Chainage 384.483 to 386.362 on NH-28, Length 1.879 Km

#### 1. Introduction

1.1 The National Highways Authority of India (NHAI) has been constituted through an Act of Parliament for faster, economical and quality Road Construction work throughout India. The National Highways Authority of India (NHAI) has been entrusted with the assignment of

### **Consultancy Services for Preparation of Feasibility Study and Detailed Project Report for:-**

- (i) 4-lane Elevated Section at Begusarai at Chainage 221.910 to 224.935 on NH-31, Length 3.025 Km
- (ii) 4-lane Elevated section of Shivala - Bihta section of Patna - Koilwar on NH-30 at design Chainage 16.050 to 29.500 of proposed alignment of NH-30, Length 13.450 Km
- (iii) 4-lane Elevated section at Gopalganj Chainage 384.483 to 386.362 on NH-28, Length 1.879 Km

NHAI now invites proposal from Technical consultants for carrying out detailed project report as per details given in Annexure-1.

1.2 A brief description of the assignment and its objectives are given in the Appendix-I, “*Terms of Reference*”.

1.3 The NHAI invites Proposals (the “**Proposals**”) *through e-tender* (on-line bid submission) for selection of Technical Consultant (the “**Consultant**”) who shall prepare detailed project report (DPR). The consultant should have expertise in carrying out the similar kind of job, in similar geographical location (particularly for hill road projects). Consultants are here by invited to submit proposal in the manner as prescribed in the RFP document. A Consultant with “a Particular Team” may submit proposals for more than one package. However, a Consultant

is not allowed to bid for a package with more than one team. For the sake of clarity, it is mentioned that one consultant cannot submit two proposals/ bids for the same package. A consultant (either as sole or as in JV/Association) can be awarded only upto 2 packages. A Consultant with “a Particular Team” may submit only one “proof of eligibility (Part 1)” and “Technical Proposal (Part II)” for any number of packages applied for by them. However, the packages for which a Consultant with “a Particular Team” applies should be clearly mentioned. Financial proposal for each package are to be submitted separately. Financial proposal are only to be submitted online and no hard copy of the financial proposal should be submitted. The most preferred bidder (H-1) for each package would be determined on the basis of Quality and Cost as mentioned in the RFP. Award of work to a Consultant with “a Particular Team” either as sole or as in JV/Association shall be limited to one package only. Joint venture shall not have more than two firms. In case, a Consultant with “a Particular Team” turns out to be the most preferred bidder (H-1) in more than one package, the package which is to be awarded to this Consultant with “a Particular Team” shall be determined on the basis of least cost to NHAI considering the financial quote of H-1 bidder and H-2 bidder limited to those packages, which shall be worked out as per the procedure given in the RFP. The consultants are hereby invited to submit proposals in the manner prescribed in the RFP.

- 1.4 The consultants shall submit proposals either in sole capacity or in JV or in Association. . In case of Joint Venture, the maximum number of Joint Venture partners is limited to 2 (i.e. one lead + 1 JV partner). The Applicant whether a sole applicant or joint venture may include an Associate company also. Any entity which has been barred by the Ministry of Road Transport and Highways (MORTH) or its implementing agencies for the works of Expressways, National Highways, ISC and EI Works and the bar subsists as on the date of application, would not be eligible to submit the bid, either individually or as a member of a Joint Venture.
- 1.5 To obtain first hand information on the assignment and on the local conditions, the consultants are encouraged to pay a visit to the client, local State PWDs and the project site before submitting a proposal and attend a pre-proposal conference. They must fully inform themselves of local and site conditions and take them into account in preparing the proposal.
- 1.6 Financial Proposals will be opened only for the firms found to be eligible and scoring qualifying marks in accordance with Para 5 hereof. The consultancy services will be awarded to the highest ranking consultant on the basis of Quality and Cost.
- 1.7 Please note that (i) costs of preparing the proposal and of negotiating the contract, including visits to the Client, etc., are not reimbursable as a direct cost of the assignment; and (ii) Client is not bound to accept any of the proposals submitted and reserve the right to reject any or all proposals without assigning any reasons.
- 1.8 The proposals must be properly signed as detailed below:

- 1.8.1
- i. by the proprietor in case of a proprietary firm
  - ii. by the partner holding the Power of Attorney in case of a firm in partnership (A certified copy of the Power of Attorney on a stamp paper of Rs. 100 and duly notarized shall accompany the Proposal).
  - iii. by a duly authorized person holding the Power of Attorney in case of a Limited Company or a corporation (A certified copy of the Power of Attorney on a stamp paper of Rs. 100 and duly notarized shall accompany the proposal).
  - iv. by the authorized representative in case of Joint Venture.
- 1.8.2 In case a Joint Venture/Association of firms, the proposal shall be accompanied by a certified copy of legally binding Memorandum of Understanding (MOU) on a stamp paper of Rs.100, signed by all firms to the joint venture confirming the following therein:
- i. Date and place of signing
  - ii. Purpose of Joint Venture/Association (must include the details of contract works for which the joint venture has been invited to bid)
  - iii. A clear and definite description of the proposed administrative arrangements for the management and execution of the assignment. Name of Lead Firm and other partner of JV should be clearly defined in the MOU
  - iv. Delineation of duties/ responsibilities and scope of work to be undertaken by each firm along with resources committed by each partner of the JV/Association for the proposed services
  - v. An undertaking that the JV firms are jointly and severally liable to the Employer for the performance of the services
  - vi. The authorized representative of the joint venture/Association shall give a Letter of Association, MOU as in i) to vi above except v, letter of Authorization, copies of GPA/SPA for the person signing the documents and a certificate of incorporation.
- 1.8.3 In case of Joint venture, one of the firms which preferably have relatively higher experience, will act as the lead firm representing the Joint Venture. The duties, responsibilities and powers of such lead firm shall be specifically included in the MOU /agreement. It is expected that the lead partner would be authorized to incur liabilities and to receive instructions and payments for and on behalf of the Joint Venture. Payment to be made to the JV can also be made to the account of the JV. For a JV to be eligible for bidding, the experience of lead partner and other partner should be as indicated in data sheet.
- 1.8.4 A firm can bid for a project either as a sole consultant or in the form of joint venture with other consultant or in association with any other consultant. However, alternative proposals i.e. one as sole or in JV with other consultant and another in association / JV with any other consultant for the same package will be summarily rejected. In such cases, all the involved proposals shall be rejected.

1.9 Pre-proposal conference shall be held on the date, time and venue given in Data Sheet.

## 1.10 Bid Security

1.10.1 The applicant shall furnish as part of its Proposal, a Bid Security of Rs.5,00,000 (Rupees Five lakhs only) in the form of a Bank Guarantee in the prescribed format given at instruction to Consultants (Form IC-I) issued by one of the Nationalized/Scheduled Banks in India in favour of the Chairman, National Highway Authority of India payable at New Delhi (the "Bid Security") valid for a minimum period of 150 days (i.e. 30 days beyond the validity of the bid) from the last date of submission of proposals. Demand Draft of Rs.5,00,000/- (Rupees Five lakhs only) can also be deposited as bid security. This Bid Security is returnable not later than 30 (thirty) days from the date of Opening of the Financial proposals except in case of the two highest ranked Applicants. Bid Security of the Selected Applicant and the Second ranked Team shall be returned, upon the Selected Applicant signing the Agreement.

1.10.2 Any Bid not accompanied by the Bid Security of the required value and minimum required validity shall be rejected by the Authority as non-responsive.

1.10.3 The NHAI shall not be liable to pay any interest on the Bid Security and the same shall be interest free.

1.10.4 The Applicant, by submitting its Application pursuant to this RFP, shall be deemed to have acknowledged that without prejudice to the NHAI's any other right or remedy hereunder or in law or otherwise, the Bid Security shall be forfeited and appropriated by the Authority as the mutually agreed pre-estimated compensation and damage payable to the Authority for, *inter alia* the time, cost and effort of the NHAI in regard to RFP including the consideration and evaluation of the Proposal under the following conditions:

- (a) If an Applicant withdraws its Proposal during the period of its validity as specified in this RFP and as extended by the Applicant from time to time.
- (b) In the case of a Selected Applicant, if the Applicant fails to sign the Agreement.

## 2 Documents

2.1 To enable you to prepare a proposal, please find and use the attached documents listed in the Data Sheet.

2.2 Consultants requiring a clarification of the documents must notify the Client, in writing, by **<1500 hrs, 10.01.2018>**. Any request for clarification in writing or by telefax/e-mail must be sent to the Client's address indicated in the Data Sheet. The Client will upload replies to pre-bid queries on its website.

2.3 At any time before the submission of proposals, the Client may, for any reason, whether at its own initiative or in response to a clarification requested by a



Consulting firm, modify the Documents by amendment or corrigendum. The amendment will be uploaded on NHA website. The Client may at its discretion extend the deadline for the submission of proposals and the same shall also be uploaded on NHA website.

### 3. Preparation of Proposal

The proposal must be prepared in three parts viz.

Part 1: Proof of eligibility

Part 2: Technical Proposal

Part 3: Financial Proposal

#### 3.1 Document in support of proof of eligibility

3.1.1 The minimum essential requirement in respect of eligibility has been indicated in the Data Sheet. The proposal found deficient in any respect of these requirements will not be considered for further evaluation. The following documents must be furnished in support of proof of eligibility as per Formats given in Appendix-II:

(i) Forwarding letter for Proof of Eligibility in the Form-E1.

- (ii) **Firm's relevant experience and performance for the last 7 years:** Project sheets in support of relevant experience as per Form-E2/T3 supported by the experience certificates from clients in support of experience as specified in data sheet for the project size preferably in terrain of similar nature as that of proposed project shall be submitted on Infracon portal in input data sheet. Certificate should indicate clearly the firms Design/DPR experience, in 2/4-/6- laning of highway, structures like bridges, Viaducts, tunnels, hill slope stabilization, rock bolting, ground improvement, etc. Scope of services rendered by the firm should be clearly indicated in the certificate obtained from the client. The information given in Form E2/T3 shall also be considered as part of Technical Proposal and shall be evaluated accordingly. The Consultants are therefore advised to see carefully the evaluation criteria for Technical Proposal and submit the Project Sheets accordingly.
- (iii) **Firm's turnover for the last 5 years:** A tabular statement as in Form E3 showing the turnover of the applicant firm(s) for the last five years beginning with the last financial year certified by the Chartered Account along with certified copies of the audit reports shall be submitted in support of the turnover shall be submitted on Infracon Portal in input data sheet.
- (iv) **Document fee:** The fee for the document amounting to Rs.5,000 (Rupees Five Thousand only) in the form of Demand Draft favoring 'National Highways Authority of India' payable at New Delhi must be furnished in a separate envelope while submitting the proposal.
- (v) **Bid Security:** Bank Guarantee in support of bid security for an amount specified in Data Sheet and having validity for a minimum period of 150 days (i.e. 30 days beyond the validity of the bid), from the last date of submission of proposals in the Form E4.
- (vi) Power of Attorney on a stamp paper of Rs.100 and duly notarized authorizing to submit the proposal.
- (vii) In case of Joint Venture/ Association of firms, the proposal shall be accompanied by a certified copy of legally binding Memorandum of Understanding (MOU) on a stamp paper of Rs.100, signed by all firms to the joint venture/ Association as detailed at para 1.8.2 above.

3.1.2 The minimum essential requirement in respect of eligibility has been indicated in the data sheet, the proposal found deficient in any respect of these requirements will not be considered for further evaluation.

## 3.2 Technical Proposal

3.2.1 You are expected to examine all terms and instructions included in the Documents. Failure to provide all requested information will be at your own risk and may result in rejection of your proposal.

- 3.2.2 During preparation of the technical proposal, you must give particular attention to the following:

*Total assignment period is as indicated in the enclosed TOR. A manning schedule in respect of requirement of key personnel is also furnished in the TOR which shall be the basis of the financial proposal. You shall make your own assessment of support personnel both technical and administrative to undertake the assignment. Additional support and administrative staff need to be provided for timely completion of the project within the total estimated cost. It is stressed that the time period for the assignment indicated in the TOR should be strictly adhered to.*

- 3.2.3 The technical proposal shall be submitted strictly in the Formats given in Appendix- III And shall comprise of following documents:

- i) Forwarding letter for Technical proposal duly signed by the authorized person on behalf of the bidder, as in Form-T-1
- ii) Details of projects for which Technical and Financial Proposals have been submitted by a Consultant with a particular Team as in Form-T-2
- iii) Firm's references - Relevant Services carried out in the last seven years as per Form- E2/T-3. This information submitted as part of Proof of Eligibility shall be evaluated and need not be submitted again as a part of the Technical proposal
- iv) Site Appreciation: limited to four A4 size pages in 1.5 space and 12 font including photographs, if any (Form-T-4).
- v) The composition of the proposed Team and Task Assignment to individual personnel: Maximum three pages (Form-T-5).
- vi) Proposed methodology for the execution of the services illustrated with bar charts of activities, including any change proposed in the methodology of services indicated in the TOR, and procedure for quality assurance: The proposed methodology should be accompanied by the consultants initial view, key challenges they foresee and potential solutions suggested regarding: a) proposed alignment and bypass required, b) land acquisition requirements, c) access control, rehabilitation of existing road, drainage and utilities, d) adoption of superior technology along with proof: limited to six A4 size pages in 1.5 space and 12 font including photographs, if any for items a to c, (Form-T-6) and information in Form-T-8 (as covered in para viii below) for item d
- vii) The proposal should clearly identify and mention the details of Material Testing lab facilities to be used by the Consultants for the project (Form-T-7). In this connection, the proposals of the Consultants to use in-house lab facilities up to a distance of maximum 400 km from the project site being feasible would be accepted. For all other cases suitable nearby material Testing Laboratory shall be proposed before Contract Agreement is executed.

- viii) The proposal shall indicate as to whether the firm is having the facilities for carrying out the following field activities or these are proposed to be outsourced to specialized agencies in the Form- T-8.
  - a) Pavement Investigation
  - b) Geo-technical Investigation

In case the consultant envisages outsourcing any or all of the above services to the expert agencies, the details of the same indicating the arrangement made with the agencies need to be furnished. These agencies would however, be subject to approval of the client to ensure quality input by such agencies before award of the work. For out-sourced services, proposed firms/consultants should have such experience on similar projects

- ix) Details of office equipment and software owned by the firm in Form-T9
- x) CVs of 4 (four) Key Personnels (Team Leader cum Senior Bridge Engineers, Bridge Engineer, Senior Highway cum Pavement Engineer & Traffic / Road Signage / Marking and Safety Expert) in Form-T-10 to be submitted only through Infracon and Team ID must be submitted in physical form. For remaining 6 (six) key personnels, the CVs need to be submitted for approval prior to signing of contract.

#### 3.2.4 CVs of Key Persons:

- i) The CVs of the four key personnel (Team leader cum Senior Bridge Engineer, Bridge Engineer, Senior Highway cum Pavement Engineer & Traffic / Road Signage / Marking and Safety expert) in the format as per Form T-10 is to be furnished on Infracon portal. It may please be ensured that the format is strictly followed and the information furnished therein is true and correct. The CV must indicate the work in hand and the duration till which the person will be required to be engaged in that assignment. If any information is found incorrect, at any stage, action including termination and debarment from future NHAI projects for a minimum period of 2 years may be taken by NHAI on the personnel and the Firm.
- ii. No alternative to key personnel may be proposed and only one CV may be submitted for each position. The minimum requirements of Qualification and Experience of all key personnel are listed in Enclosure-II of TOR. CV of a person who does not meet the minimum experience requirement as given at enclosure-II of TOR shall be evaluated and the marks obtained shall be taken into consideration during evaluation of Technical Proposal (except Team leader). However if a firm with such key personnel is declared the “most preferred bidder” for a particular package, such key personnel should be replaced before signing of contract with a person meeting requirements of Qualification and Experience as given at enclosure-II of TOR and whose CV secures 75 % marks and above. If a proposed key personnel does not possess the minimum (essential)

educational qualification as given at enclosure-II of TOR, Zero marks shall be assigned to such CV and such CV shall not be evaluated further. **The CV of the proposed Team Leader should score at least 75 % marks otherwise the entire proposal shall be considered to have failed in the evaluation of Technical Proposals and shall not be considered for opening of Financial Proposals.**

- iii. Team Leader, Highway cum Pavement Engineer, Bridge Engineer, Geo-technical cum material engineer and Senior Survey Engineer should be available from beginning of the project. 2 Key Personnel namely Quantity Surveyor/Documentation expert and Traffic/ Road Signage/Marking and safety Expert are allowed to be deployed/proposed in 2 teams at a time. **If same CV is submitted by two or more firms, zero marks shall be given for such CV for all the firms.**
- iv. The availability of key personnel must be ensured for the duration of the project as per proposed work programme. If a firm claims that a key personnel proposed by them is a permanent employee of the firm (the personnel should have worked in the firm continuously for a period of at least 1 year), a certificate to the effect be furnished by the firm.
- v. The age limit for key personnel is 65 years as on the date of bid submission. The proof of age and qualification of the key personnel must be furnished in the technical proposal.
- vi. An undertaking from the key personnel must be furnished that he/she will be available for entire duration of the project assignment and will not engage himself/herself in any other assignment during the period of his/her assignment on the project. After the award of work, in case of non-availability of key personnel in spite of his/her declaration, he/she shall be debarred for a period of two years for all projects of NHAI and MoRTH.
- vii. Age limit for supporting staff to be deployed on project is 65 years as on the date of bid submission.
- viii. A good working knowledge of English Language is essential for key professional staff on this assignment. Study reports must be in English Language.
- ix. Photo, contact address and phone/mobile number of key personnel should be furnished in the CV.
- x. Availability of few key personnel engaged for preparation of Detailed Project Report for the envisaged project may be ensured during first 3 to 4 months after start of the civil work at site during the period of survey and review of DPR by the Supervision consultant/Authority Engineer. For this purpose, payment shall be made as per actual site deployment of the key personnel at the man month rates quoted by the firm in their financial proposal.

- xi. It may please be noted that in case the requirement of the 'Experience' of the firm/consortium as mentioned in the "Proof of Eligibility' is met by any foreign company, their real involvement for the intended project shall be mandatory. This can be achieved either by including certain man-months input of key experts belonging to the parent foreign company, or by submitting at least the draft feasibility report and draft DPR duly reviewed by the parent firm and their paying visit to the site and interacting with NHAI. In case of key personnel proposed by the foreign company, they should be on its pay roll for at least last six months (from the date of submission).
- xii. In case a firm is proposing key personnel from educational/research institutions, a '**No Objection Certificate**' from the concerned institution should be enclosed with the CV of the proposed key personnel committing his services for the instant project.

3.2.5 The technical proposal must not include any financial information.

### 3.3 Financial Proposal

3.3.1 The Financial proposal should include the costs associated with the assignment. These shall normally cover: remuneration for staff (foreign and local, in the field, office etc.), accommodation, transportation, equipment, printing of documents, surveys, geotechnical investigations etc. This cost should be broken down into foreign and local costs. Your financial proposal should be prepared strictly using, the formats attached in **Appendix - IV**. Your financial proposal should clearly indicate the amount asked for by you without any assumptions of conditions attached to such amounts. Conditional offer or the proposal not furnished in the format attached in **Appendix-IV** shall be considered non-responsive and is liable to be rejected.

3.3.2 The financial proposal shall take into account all types of the tax liabilities and cost of insurance specified in the Data Sheet.

3.3.3 **Costs shall be expressed in Indian Rupees in case of domestic as well as for foreign Consultant.** The payments shall be made in Indian Rupees by the National Highways Authority of India and the Consultant themselves would be required to obtain foreign currency to the extent quoted and accepted by NHAI. Rate for foreign exchange for payment shall be at the rate established by RBI applicable at the time of making each payment installment on items involving actual transaction in foreign currency. No compensation done to fluctuation of currency exchange rate shall be made.

3.3.4 Consultants are required to charge only rental of equipments / software(s) use so as to economize in their financial bid.

#### 4 Submission of Proposals

4.1 The Applicants shall submit the proposal (Proof of Eligibility and Technical Proposal) in hard bound form with all pages numbered serially and by giving and index of submissions. Applications submitted in other forms like spiral bound form; loose form etc shall be rejected. Copies of Applications shall not be submitted and considered. A Consultant with “a Particular Team” may submit only one hard copy (in original) of “proof of eligibility (Part 1)” and “Technical Proposal (Part II)” to NHAI for all the packages applied by them with a particular team on or before the deadline of submission of bids. A consultant can apply for a particular package with one team only. The packages for which a Consultant with “a Particular Team” applies should be clearly mentioned in their proposal. However, Consultants are required to submit a copy of Proof of Eligibility and Technical Proposal online separately for each package. Financial proposal for each package are to be submitted separately. Financial proposal are only to be submitted online and no hard copy of the financial proposal should be submitted.

4.2 You must submit original proposal as indicated in the Data Sheet. “Proof of Eligibility” in original and hard bound should be enclosed in an envelope which should be marked as “Part-I - Proof of Eligibility”. Similarly, “Technical Proposal” in original and hard bound should be enclosed in an envelope which should be marked as “Part-II - Technical Proposal” The proposal will be sealed in an outer envelope which will bear the address and information indicated in the Data Sheet and shall be submitted to NHAI on or before the deadline for submission of bids. The envelope must be clearly marked:

##### Consultancy Project Name

#### **Consultancy Services for Preparation of Feasibility Study and Detailed Project Report for:-**

- (i) 4-lane Elevated Section at Begusarai at Chainage 221.910 to 224.935 on NH-31, Length 3.025 Km
- (ii) 4-lane Elevated section of Shivala - Bihta section of Patna - Koilwar on NH-30 at design Chainage 16.050 to 29.500 of proposed alignment of NH-30, Length 13.450 Km
- (iii) 4-lane Elevated section at Gopalganj Chainage 384.483 to 386.362 on NH-28, Length 1.879 Km

**Do not open, except in presence of the evaluation committee**

4.2.1 This outer envelope will contain three separate envelopes. The first envelope containing “Proof of Eligibility” (which should be clearly marked), the second envelope containing “Technical Proposal” (which should be clearly marked) and the third envelope containing a demand draft of Rs.5,000/- (cost of RFP), Bid Security of required amount and validity as mentioned in the RFP. Only

one bid security and one DD of Rs.5,000/ (as cost of Document) may be submitted by a consultant applying with a particular team for a number of packages. However for consultants applying with 2 teams, 2 nos. of Bid Security of Rs 5 lakhs each and 2 no's of DD of Rs.5,000/ each as mentioned in RFP have to be submitted.

- 4.2.2 The proposal must be prepared in indelible ink and must be signed by the authorized representative of the consultants. The letter of authorization must be confirmed by a written power of attorney accompanying the proposals. All pages of the Proof of Eligibility and Technical Proposal must be initialed by the person or persons signing the proposal.



- 4.3 The proposal must contain no interlineations or overwriting except as necessary to correct errors made by the Consultants themselves, in which cases such corrections must be initialed by the person or persons signing the proposal.
- 4.4 Your completed Proof of eligibility and Technical proposal (in hard copy) must be delivered on or before the scheduled time and date at the address stated in Data Sheet. Proof of Eligibility, Technical Proposal and Financial Proposal for each package shall have to be submitted online also on or before the time and date at the address stated in Data Sheet
- 4.5 Your proposal must be valid for the number of days stated in the Data Sheet from the closing date of submission of proposal.

## 5 **Proposal Evaluation**

### 5.1 **Stage I- Proof of Eligibility**

The proposals would be evaluated by a Committee constituted by Chairman, NHAI. A three-stage procedure will be adopted in evaluating the proposal. In the first stage- Proof of Eligibility, it will be examined as to whether:

- i) The proposal is accompanied by Document fee
- ii) The Proposal is accompanied by Bid Security of required value and of validity equal or more than the minimum required validity
- iii) The firms(s) have required experience
- iv) The firms(s) have required turnover
- v) The documents are properly signed by the authorized signatories and whether the proposal contains proper POA as mentioned at para 1.8.1 above
- vi) The proposals have been received on or before the dead line of submission.
- vii) In case a Joint Venture/Association of firms, the proposal shall be accompanied by a certified copy of legally binding Memorandum of Understanding (MOU) on a stamp paper of Rs.100, signed by all firms to the joint venture/Association as detailed at para 1.8.2 above

In case answers to any of the above items is 'No' the bid shall be declared as non- responsive and shall not be evaluated further.

A Consultant satisfying the minimum Eligibility Criteria as mentioned in the Data sheet and who had submitted the above mentioned documents shall be declared "pass" in Proof of Eligibility and the Technical Proposals of only those consultants shall be opened and evaluated further.

### 5.2 **Stage II- Technical evaluation**

In the second stage the Technical proposal shall be evaluated as per the detailed evaluation criteria given in Data Sheet.

A proposal securing 75 points shall be declared pass in the evaluation of Technical Proposal .**The technical proposal should score at least 75 points out of 100 to be considered for financial evaluation. The CV of the proposed**

**Team Leader should score at least 75 % marks otherwise the entire proposal shall be considered to have failed in the evaluation of Technical Proposals and shall not be considered for opening of Financial Proposals.**

### **5.3 Stage III- Evaluation of Financial Proposal**

5.3.1 In case for a particular package, only one firm is eligible for opening of Financial Proposals, the Financial Proposal shall not be opened, the bids for that package shall be cancelled and NHAI shall invite fresh bids for this package. For financial evaluation, total cost of financial proposal excluding Goods & Service Tax shall be considered. Goods & Service Tax shall be payable extra.

5.3.2 The evaluation committee will determine whether the financial proposals are complete (i.e. whether they have included cost of all items of the corresponding proposals; if not, then their cost will be considered as NIL but the consultant shall however be required to carry out such obligations without any compensation. In case, if client feels that the work cannot be carried out within overall cost of financial proposal, the proposal can be rejected. The client shall correct any computational errors and correct prices in various currencies to the single currency specified in Data Sheet. The evaluation shall exclude those taxes, duties, fees, levies and other charges imposed under the applicable law & applied to foreign components/ resident consultants.

5.3.3 For a package, the procedure as mentioned at Clauses 5.3.4, 5.4 and, 5.5 as mentioned below shall be followed for determining the “most preferred bidder (H-1 bidder)” for this package.

5.3.4 The lowest financial proposal (FM) will be given a financial score (SF) of 100 points. The financial scores of other proposals will be computed as follows:

$$SF = 100 \times FM / F$$

(SF = Financial Score, FM= Amount of lowest bid, F= Amount of financial proposal converted in the common currency)

5.4 Combined evaluation of Technical and Financial Proposals.  
Proposals will finally be ranked according to their combined technical (ST) and Financial (SF) scores using the weights indicated in the Data Sheet:

$$S = ST \times T + SF \times f$$

Where,

S= Combined Score,

ST= Technical Score out of 100

SF= Financial Score out of 100

T and f are values of weightage for technical and financial proposals respectively as given in the Data Sheet.

### **5.5 Most Preferred Bidder (H-1).**

For a particular package, a Consultant with a “particular Team” having the maximum Combined score (S) shall be declared as the **most preferred bidder (H-**

- 5.6 In case work has to be awarded for multiple packages, award of work to a Consultant with “a Particular Team” either as sole or as in JV/Association shall be limited to one package only. At first, Consultants who become H-1 in one package each shall be assigned the respective package. Then packages in which a Consultant with “a Particular Team” turns out to be the most preferred bidder (H-1) in more than one package shall be considered. In case, a Consultant with “a Particular Team” turns out to be the most preferred bidder (H-1) in more than one package, the package which is to be awarded to this team of a consultant shall be determined on the basis of least cost to NHAI considering the Financial Quote of H-1 bidder and H-2 Bidder limited to those packages. Procedure to be followed for awarding work based on QCBS including assessment of least cost to NHAI under special circumstances i.e. When a Consultant with “a Particular Team” turns out to be the most preferred bidder (H-1) in more than one package is given at given at Annex-II.

## 6 Performance Security

- 6.1 The consultant will furnish within 15 days of the issue of Letter of Acceptance (LOA), an unconditional Bank Guarantee equivalent to 10% of the total contract value from a Nationalized Bank, IDBI or ICICI/ ICICI Bank/ Foreign Bank/ EXIM Bank / Any Scheduled Commercial Bank approved by RBI having a net worth of not less than Rs.500 crore as per latest Annual Report of the Bank. In the case of a Foreign Bank (issued by a Branch in India) the net worth in respect of Indian operations shall only be taken into account. In case of Foreign Bank, the BG issued by Foreign Bank should be counter guaranteed by any Nationalized Bank in India. In case of JV, the BG shall be furnished on behalf of the JV or by the lead member of the JVs for an amount equivalent to **10%** of the total contract value to be received by him towards Performance Security valid for a period of **three years** beyond the date of completion of services, or end of civil works contract, whichever earlier. **The Bank Guarantee will be released by NHAI upon expiry of 3 years beyond the date of completion of services, or end of civil works contract, whichever earlier, provided rectification of errors if any, found during implementation of the contract for civil work and satisfactory report by NHAI in this regard is issued. However, if contract is foreclosed / terminated by NHAI at Inception Stage, with no fault of Consultant, Performance Security shall be released within three months from date of forecloser / termination.** If a Consultant fails to submit the Performance Security (as specified above), it shall attract penalty -encashment of Bid Security submitted by the Consultant.
- 6.2 As an alternative to the contents of Para 1.10 and Para 6.1 above, a single Bank Guarantee to cover for the performance of all projects under NHAI may also be deposited as tabulated below, at the discretion of the consultant, instead of depositing separately again and again. The Consultant may initially provide the Performance Security for a period of two years provided that it shall procure the extension of the validity of the Performance Security at least one month prior to the date of expiry thereof. Once the appropriate single Bank Guarantee for Performance Security has been submitted by the Consultant, the existing BGs shall be returned. The Bank Guarantee be submitted in prescribed Performa.

Performance Security	
Remaining cumulative Value of Consultancy Fee as per Contracts under a Agency (NHA) (Cr)	BG Value (in Rs. Crores.)
0-20	0.5
20-40	1
40-100	2.50
100-200	4.0
Beyond 200	5.0

**7. Penalty**

The consultant will indemnify for any direct loss or damage that accrue due to deficiency in services in carrying out Detailed Project Report. Penalty shall be imposed on the consultants for poor performance/ deficiency in service as expected from the consultant and as stated in General Conditions of Contract.

**8. Award of Contract**

The Client shall issue letter of award to selected Consultant and ask the Consultant to provide Performance Security as in Para 6 above. If the selected Consultant fail to provide performance security within the prescribed time or the Consultant fail to sign the Contract Agreement within prescribed time the Client may invite the 2<sup>nd</sup> highest ranking bidder Consultant and follow the procedure outlined in Para 8 and 9 of this Letter of Invitation.

**9. Signing of Contract Agreement**

After having received the performance security and verified it, the Client shall invite the selected bidder for signing of Contract Agreement on a date and time convenient to both parties within 15 days of receipt of valid Performance Security.

**10. The Client shall keep the bidders informed during the entire bidding process and shall host the following information on its website:**

- i) Notice Inviting Tender (NIT)
- ii) Request For Proposal (RFP)
- iii) Replies to pre-bid queries, if any
- iv) Amendments / corrigendum to RFP
- v) List of bidders who submitted the bids up to the deadline of submission
- vi) List of bidders who did not pass the eligibility requirements, stating the broad deficiencies
- vii) List of bidders who did not pass the Technical Evaluation stating the reasons.
- viii) List of bidders along with the technical score, who qualified for opening the financial bid
- ix) Final Score of qualified bidders
- ix) Name of the bidders who is awarded the Contract

**11. Confirmation**

We would appreciate you informing us by facsimile/e-mail *whether or not you will submit a proposal.*

Thanking you.

**Encl. as above**

## Annex-1

### Details of the stretch proposed for DPR preparation

<b>S. No.</b>	<b>NH No.</b>	<b>Section</b>	<b>State</b>	<b>Tentative Length (in km)</b>	<b>Package No.</b>
<b>1</b>	<b>2</b>	<b>3</b>	<b>4</b>	<b>5</b>	<b>6</b>
	31	4-lane Elevated Section at Begusarai at Chainage 221.910 to 224.935 on NH-31	Bihar	3.025	
	30	4-lane Elevated section of Shivala - Bihta section of Patna - Koilwar on NH-30 at design Chainage 16.050 to 29.500 of proposed alignment of NH-30	Bihar	13.450	
	28	4-lane Elevated section at Gopalganj Chainage 384.483 to 386.362 on NH-28	Bihar	1.879	

## Annex-II

### Procedure of Awarding Work based on QCBS including Assessment of Least Cost to NHAI under Special Circumstances i.e. When a Consultant with a particular team becomes H-1 bidder in more than one package

A Consultant with a particular Team can apply for any number of packages with one team. However, Award of work to a Consultant with “a Particular Team” either as sole or as in JV/Association shall be limited to one package only. Following procedure shall be followed for the selection of the most preferred bidder for the consultancy assignment:

1. **At first, Consultants who become H-1 in one package each shall be assigned the respective package.** Then packages in which a Consultant with “a Particular Team” turns out to be the most preferred bidder (H-1) in more than one package shall be considered. In case, a Consultant with “a Particular Team” turns out to be the most preferred bidder (H-1) in more than one package, the package which is to be awarded to this team of a consultant shall be determined on the basis of least cost to NHAI considering the Financial Quote of H-1 bidder and H-2 Bidder limited to those packages which shall be worked out as per procedure illustrated with an example as mentioned below.
2. Suppose there are 8 packages namely Package-1, Package-2, Package -3, Package-4, Package -5, package -6, package-7 and Package-8 respectively. It is also assumed that 10 consultants namely P, Q, R, S, T, U, V, W, X and Y has applied for these packages. It is also assumed that three Consultants namely P, R and U has applied with two Teams and the remaining Consultants have applied with only one team. It is also assumed that the following is the position of various firms after opening of the Financial proposals (and after arithmetic corrections if any of the Financial bids) of the packages and after applying QCBS

	H-1	H-2	H-3	H-4	H-5	H-6
Package no.	Name of Consultants and Financial Quotes (Rs in lakhs)					
Package-1	P (team-1)	Q	W	X	T	Y
	230 lakhs	200 lakhs	240 lakhs	220 lakhs	200 lakhs	230 lakhs
Package-2	V	U(team-1)	X	P (team-2)	T	Y
	240 lakhs	210 lakhs	240 lakhs	220 lakhs	200 lakhs	230 lakhs
Package-3	V	P(team-1)	U(team-1)	R (team-2)	X	Y
	200 lakhs	230 lakhs	250 lakhs	230 lakhs	220 lakhs	200 lakhs
Package-4	R (team-1)	T	U (team-2)	P (team-2)	Y	X
	250 lakhs	220 lakhs	250 lakhs	260 lakhs	220 lakhs	245 lakhs
Package-5	R (team-1)	V	S	U(team-2)	W	T
	220 lakhs	240 lakhs	260 lakhs	250 lakhs	220 lakhs	240 lakhs
Package-6	Q	T	S	P (team-2)	W	U (team-2)
	210 lakhs	240 lakhs	250 lakhs	220 lakhs	200 lakhs	230 lakhs
Package-7	R (team-1)	U (team-1)	Q	S	W	Y
	200 lakhs	220 lakhs	240 lakhs	255 lakhs	230 lakhs	240 lakhs
Package-8	V	R(team-1)	W	S	P (team-1)	Y
	190 lakhs	250 lakhs	220 lakhs	240 lakhs	255 lakhs	240 lakhs

The different packages shall be awarded to consultants as mentioned below:

## 2.1 **Step-1:**

In this case, Consultants P (team-1) and Q are the H-1 in only one package each namely package-1 and package-6 respectively. Consultant V is H-1 in 3 packages namely Package-2, Package-3 and Package-8 respectively. Consultant R (team-1) is H-1 in 3 packages namely Package-4, Package-5 and Package-7 respectively. Since Consultant P (team-1) is H-1 in Package-1 only and Consultant Q is H-1 in Package-6 only, **Consultant P (team-1) shall be awarded Package-1 and Consultant Q shall be awarded Package-6.**

## 2.2 **Step-2:**

**After Consultant P (team-1) is awarded Package-1 and Consultant Q is awarded Package-6, the scenario for the remaining 6 packages is as given below .P (team-1) and Q occurring anywhere else stands deleted as they have already been awarded one work each**

	H-1	H-2	H-3	H-4	H-5	H-6
Package No.	Name of Consultants and Financial Quotes (Rs in lakhs)					
Package-2	V	U(team-1)	X	P (team-2)	T	Y
	240 lakhs	210 lakhs	240 lakhs	220 lakhs	200 lakhs	230 lakhs
Package-3	V	U(team-1)	R (team-2)	X	Y	
	200 lakhs	250 lakhs	230 lakhs	220 lakhs	200 lakhs	
Package-4	R (team-1)	T	U (team-2)	P (team-2)	Y	X
	250 lakhs	220 lakhs	250 lakhs	260 lakhs	220 lakhs	245 lakhs
Package-5	R (team-1)	V	S	U (team-2)	W	T
	220 lakhs	240 lakhs	260 lakhs	250 lakhs	220 lakhs	240 lakhs
Package-7	R (team-1)	U (team-1)	S	W	Y	
	200 lakhs	220 lakhs	255 lakhs	230 lakhs	240 lakhs	
Package-8	V	R(team-1)	W	S	Y	
	190 lakhs	250 lakhs	220 lakhs	240 lakhs	240 lakhs	

Consultant V shall be awarded only one package out of the 3 packages for which it is H-1 namely Package-2, Package-3 and Package-8 respectively. Similarly Consultant R (team-1) shall be awarded only one package out of the 3 packages for which it is H-1 namely Package-4, Package-5 and Package-7 respectively. The determination of package to be awarded to Consultant V and Consultant R (team-1) shall be worked out in a single step (i.e. one at a time) .New H-1 for the remaining packages (4 packages) shall be worked out only after determination of packages to be awarded to the H-1 bidders at this stage [i.e. Consultant V and R (Team-1) in the instant case] in one step . Determination of Package to be awarded to each of Consultant V and Consultant R (team-1) shall be worked out as follows



- (i) After the award of Package-1 to Consultant -P (team-1) and Package -6 to Consultant -Q and also considering that a Consultant with a particular team can be awarded only one work, the details of H-1 and H-2 / New H-2 in the remaining 6 packages are as mentioned below .Since V is H-1 in more than one package and shall be awarded one of these packages, V has been deleted from all other packages .Similarly, since R(Team-1) in more than one package and shall be awarded one of these packages, R (Team-1) has been deleted from all other packages

	H-1	H-2 / New H-2	Remarks
Package-2	V	U(team-1)	
	240 lakhs	210 lakhs	
Package-3	V	U(team-1)	Since Consultant P (Team-1) is awarded Package-1, Consultant <b>U (team-1) becomes the new H-2</b>
	200 lakhs	250 lakhs	
Package-4	R (team-1)	T	
	250 lakhs	220 lakhs	
Package-5	R (team-1)	S	
	220 lakhs	260 lakhs	
Package-7	R (team-1)	U (team-1)	
	200 lakhs	220 lakhs	
Package-8	V	W	Consultant-R(team-1) has not been considered as H-2 since Consultant -C (team-1) is to be awarded one package out of the packages 4,5 and 7 in which it is H-1. Hence <b>Consultant - W is the new H-2</b>
	190 lakhs	220 lakhs	

- (ii) Package to be awarded to Consultant -V who is H-1 in three packages namely Package - 2, 3 and 8 respectively shall be determined on the basis of least cost to NHAI considering the Financial Quote of H-1 bidder and H-2 Bidder limited to those packages The situation for least cost to NHAI shall be when the firm with Consultant -G is awarded the package for which **Financial Bid of second ranked team (H-2) minus\_ Financial Bid of the first ranked team (H-1) is maximum.** The same is illustrated as given below

	H-1	H-2 / New H-2	Financial Bid of H-2/ New H-2 <u>minus</u> Financial Bid of H-1	Remarks
Package-2	V	U(team-1)	210-240 = (-) 30 lakhs	
	240 lakhs	210 lakhs		
Package-3	V	U(team-1)	250 – 200 = (+) <b>50 lakhs</b>	H-2 minus H-1 is Maximum. Hence <b>Consultant V shall be awarded Package-3</b>
	200 lakhs	250 lakhs		
Package-8	V	W	220 – 190 = (+) 30 lakhs	

In a similar way, **Package to be awarded to Consultant - R (team-1) who is H-1 in three packages namely Package -4, 5 and 7 respectively shall be determined as illustrated below:**

	H-1	H-2 / New H-2	Financial Bid of H-2/ New H-2 <u>minus</u> Financial Bid of H-1	Remarks
Package-4	R (team-1)	T	220-250 = (-) 30 lakhs	
	250 lakhs	220 lakhs		
Package-5	R (team-1)	S	260 – 220 = (+) <b>40 lakhs</b>	H-2 minus H-1 is <b>Maximum.</b> Hence <b>Consultant – R (team- 1) shall be awarded Package- 5</b>
	220 lakhs	260 lakhs		
Package-7	R (team-1)	U (team-1)	220 – 200 = (+) 20 lakhs	
	200 lakhs	220 lakhs		

### 2.3 Step-3

- (i) **After the award of the above mentioned 4 packages namely, Package-1 to Consultant-P (team-1), Package -6 to Consultant -Q, Package -3 to Consultant -V, Package -5 to Consultant -R (team-1) and also considering that a Consultant with a particular team can be awarded only one work, the details of new H-1 and New H-2 in the remaining 4 packages are as mentioned below**

	H-1 (New H-1)	H-2 (New H-2)	Remarks
Package-2	U(team-1)	X	Since Consultant V is awarded Package-3 , <b>Consultant U (team-1) becomes the new H-1 and Consultant X becomes the new H-2</b>
	210 lakhs	240 lakhs	
Package-4	T	U (team-2)	Since Consultant -R(team-1) is awarded Package-5 , <b>Consultant T becomes the new H-1 and Consultant U (team-2) becomes the new H-2</b>
	220 lakhs	240 lakhs	
Package-7	U (team-1)	S	Since Consultant R(team-1) is awarded Package-5 , <b>Consultant U (team-1) becomes the new H-1 and Consultant S becomes the new H-2</b>
	220 lakhs	255 lakhs	
Package-8	W	S	Since Consultant V is awarded Package-3 , <b>Consultant W becomes the new H-1 and Consultant S becomes the new H-2</b>
	220 lakhs	240 lakhs	

- (ii) **Consultant T is the new H-1 for only one package namely Package-4. Similarly Consultant W is the new H-1 for only one package namely Package-8. Accordingly Package- 8 shall be awarded to Consultant-W and Package -4 shall be awarded to Consultant-T.**

2.4 **Step-4:**

Consultant U (team-1) is the new H-1 for package- 2 and Package-7 respectively and Consultant U (team-1) shall be awarded only one package out of this 2 packages. Package to be awarded to Consultant -U (team-1) shall be determined as illustrated below

	H-1	H-2 / New H-2	Financial Bid of H-2/ New H-2 <u>minus</u> Financial Bid of H-1	Remarks
Package-2	U(team-1)	X	240-210 = (+) 30	
	210 lakhs	240 lakhs	lakhs	
Package-7	U (team-1)	S	255 – 220 = (+) 35	H-2 minus H-1 is Maximum. Hence <b>Consultant – U (team-1) shall be awarded Package-7</b>
	220 lakhs	255 lakhs	lakhs	

2.5 **Step-5 :**

- (i) **After the award of the above mentioned 7 packages** namely, Package-1 to Consultant-P (team-1) , Package -6 to Consultant -Q, Package -3 to Consultant -V, Package -5 to Consultant -R (team-1), Package-4 to Consultant -T, Package -8 to Consultant-W, package-7 to Consultant -U (team-1) team and also considering that a Consultant with a particular team can be awarded only one work , **the details of new H-1 and / New H-2 in the remaining package i.e. package -2 is as mentioned below**

	H-1 (New H-1)	H-2 (New H-2)	Remarks
Package-2	X	A (team-2)	Since Consultant V is awarded Package-3 and <b>Consultant U (team-1) is awarded package-7 , Consultant X becomes the new H-1 and Consultant P(team-2) becomes the new H-2</b>
	240 lakhs	220 lakhs	

- (ii) Consultant X is the new H-1 for only one package namely Package-2. Accordingly, Package -2 shall be awarded to Consultant -X.

3. Thus as per the above mentioned procedure **the 8 packages are awarded to the following Consultant at the Financial Quoted (after arithmetic Corrections) by them for the respective packages**

Package No.	Name of Consultants awarded packages
Package-1	Consultant- P (team-1)
Package-2	Consultant- X
Package-3	Consultant- V

Package-4	Consultant- T
Package-5	Consultant- R (team-1)
Package-6	Consultant- Q
Package-7	Consultant- U (team-1)
Package-8	Consultant- W

## DATA SHEET

I (References to corresponding paragraphs of LOI are mentioned alongside)

1. **The Name of the Assignment and description of project as mentioned in Annex-I (Ref. Para 1.1)**

(The Name of project and Package No. should be indicated in the format given in the technical proposal)

2. **The name of the Client is :** Chairman  
National Highways Authority of India  
G5&6, Sector-10, Dwarka  
New Delhi-110075

3. **Duration of the Project:** 120 days

4. **Date, Time and Venue of Pre-Proposal Conference**

**Date:** <10.01.2018>

**Time:** <1500 hrs>

**Venue:** National Highways Authority of India  
G5&6, Sector-10  
Dwarka-New Delhi-110075, India (Ref. Para 1.9)

5. **The Documents are:**

- |       |                |                                  |
|-------|----------------|----------------------------------|
| i.    | Appendix-I:    | Terms of Reference (TOR)         |
| ii)   | Appendix-II    | Formats for Proof of Eligibility |
| iii.  | Appendix-III:  | Formats for Technical Proposal   |
| iv.   | Appendix-IV:   | Formats for Financial Proposal   |
| v.    | Appendix-V:    | Detailed Evaluation Criteria     |
| vi.   | Appendix -VI   | Draft Contract Agreement         |
| vii.  | Appendix -VII  | DPR Checklist                    |
| viii. | Appendix -VIII | Sample Executive Summary         |

(Ref. Para 2.1)

6. **Bid Security: Rs.5 Lakhs** (Ref Para 1.10)

7. **Tax and Insurance (Ref. Para 3.3.2)**

(i). The Consultants and their personnel shall pay all taxes (including Goods & service tax), custom duties, fees, levies and other impositions levied under the laws prevailing seven days before the last date of submission of the bids. The effects of any increase / decrease of any type of taxes levied by the Government shall be borne by the Client / Consultant, as appropriate.

(ii). Limitations of the Consultant's Liability towards the Client shall be as per Clause 3.4 of Draft Contract Agreement

(iii). The risk and coverage shall be as per Clause 3.5 of Draft Contract Agreement.

8. The number of copies of the proposal required to be submitted: 1 no. (ref. para 4.1)

9. The address is --- (Ref. para 4.2)  
General Manager (Tech) Bihar  
National Highways Authority of India  
G5&6, Sector-10  
Dwarka-New Delhi-110075  
Tel: 011 25074100/4200 Extn. 1821

The envelopes must be clearly marked:

- i. Original Proposal;
- ii. Documents in proof of eligibility and technical proposal as appropriate; and,
- iii. Do not open, except in presence of the evaluation committee on the outer envelope.
- iv. Consultancy Package No. :-----
- v. Project Name: -----
- vi. Name and Address of Consultant

10. The date, time and Address of proposal submission are

**Date** <25.01.2018>  
**Time** <1100 hrs>  
**Address** National Highways Authority of India (NHAI)  
G-5&6, Sector-10  
Dwarka-New Delhi-10075

(Ref. Para 4.4)

11. Proposal Validity period (Number of days): 120 days (Ref. Para 4.5)

12. Evaluation criteria: (Ref. Para 3 & 5)

12.1 First stage evaluation - eligibility requirement. (Ref. Para 3.1 & 5.1)

**Table-1: Minimum Eligibility Requirements**

Sr. No.	Minimum experience and performance of Preparation of DPR of Highways / Bridges in the last 7 years (NH/SH/Equivalent) (for past performance attach undertaking for any litigation history/ and arbitration).	Annual average turnover
1	<p>A Firm applying for a package should have Experience of preparation of Detailed Project Report of 2/4/6 lane Bridge/Flyover/ROB/viaduct/grade separator/any other major elevated structure of aggregate length equal to the indicative 13.500 Km ). Firm should have also prepared DPR for at least one project of 2/4/6 lane Bridge/Flyover/ROB/viaduct/grade separator/any other major elevated structure of minimum 1000 Meter or Feasibility Study minimum of 1200 Meter.</p> <p>Note: The experience of a firm in preparation of DPR for a private concessionaire/contractor shall be considered only if the experience certificate is authenticated by the concerned competent Government department / Authority.</p>	Annual average turnover for last 5 years of the firm should be equal to or more than <b>Rs.5.00 Crores.</b>

- i) The sole applicant shall fulfill all the requirements given in Table-1.
- (ii) In case of JV, the Lead Partner should fulfill at least 75% of all eligibility requirements and the other partner shall fulfill at least 50% of all eligibility requirements.
- (iii) If the applicant firm has / have prepared the DPR/FS projects solely on its own, 100% weightage shall be given. If the applicant firm has prepared the DPR/FS projects as a lead partner in a JV, 75% weightage shall be given. If the applicant firm have prepared the DPR projects as the other partner (not lead partner) in a JV 50% weightage shall be given. If the applicant firm have prepared the DPR/FS projects as an associate, 25% weightage shall be given.
- (iv) Similar project means 2/4/6 lane as applicable for the project for which RFP is invited. For 2-lane projects experience of 4/6 lane also to be considered with a multiplication factor of 1.5. Experience of 4/6 lane shall be considered interchangeably for 4/6 laning projects. For 4/6 laning projects, experience of 2 lane will be considered with a multiplication factor of 0.4, but only for those 2 lane projects whose cost of consultancy services was more than Rs.1.0 crore

## 12.2 Second stage technical evaluation (Refer 5.2)

<b>S. No.</b>	<b>Description</b>	<b>Points</b>
1	Firm's relevant experience in last 7 years	25
2	Adequacy of approach and methodology	5
3	Material testing, survey & investigation, equipment and software proposed to be used	20
4	Qualification and Relevant experience of the proposed key personnel	50
	<u>Total</u>	100



Further break-up of each criteria has been detailed out below:

### A. Firm's relevant experience in last 7 years (25)

For special projects such as special bridges, tunnels and expressways that require specialized capabilities and skill sets, the following is the break-up:

S. No.	Description	Maximum Points	Sub-Points
1	<b>Specific experience of the DPR consultancy related to the assignment for eligibility</b>	14	
1.1	<b>Aggregate Length of DPR / Feasibility study of 13.500 Km 2/4/6 lane Bridge/Flyover/ROB/viaduct/grade separator/any other major elevated structure</b>	7	
1.1.1	More than the indicative Length of the package applied for		4
1.1.2	More than 2 times the indicative length of the package applied for		6
1.1.3	More than 3 times the indicative length of the package applied for		7
1.2	<b>DPR for 2/4/6 Bridge/Flyover/ROB/viaduct/grade separator/any other major elevated structure projects each equal to 1000 meter or more (or Feasibility Study for 2/4/6 Bridge/Flyover/ROB/viaduct/grade separator/any other major elevated structure projects each equal to or more than 1200 meter)</b>	7	
1.2.1	1 project		4
1.2.2	2 projects		6
1.2.3	3 or more projects		7
2	<b>DPR of Bridge having length more than 500 m</b>	3	
2.1	1 bridge		1
2.2	2 bridges		2
2.3	3 or more bridges		3
3	<b>Specific experience of firms in terms of turnover</b>	3	
3.1	Firm's Average Turnover of last 5 years > 50 crore		3
3.2	Firm Average Turnover of last 5 years 20-50 crore		2.5
3.3	Firm Average Turnover of last 5 years 5 - 20 crore		2
4	<b>DPR for standalone Special bridges</b>		
4.1	<b>DPR of number of special bridges/</b>	5	
4.1.1	<b>1 project</b>		1

S. No.	Description	Maximum Points	Sub-Points
4.1.2	2 projects		2
4.1.3	3 projects		3
4.1.4	4 projects		4
4.1.5	5 or more projects		5

Note: In case feasibility study is a part of DPR services the experience shall be counted in DPR only. In case bridge is included as part of DPR of highway the experience will be (1) and (2)

### B. Adequacy of approach and methodology (5)

S. No	Description	Points	
1	Site appreciation	1	
2	Team composition and task assignment	1	
3	Methodology*	3	
<b>3.1</b>	<b>Approach and initial view on project plan including key challenges envisaged and potential solutions for</b>		
3.1.1	Proposed alignment and bypasses required and land acquisition requirements		1
3.1.2	Access control, rehabilitation of existing road, drainage and utilities		1
<b>3.1.3</b>	<b>Adoption of superior technology along with proof of past use vendor association</b>		1
	Total	5	

\*Higher marks for adoption of superior technology in data collection, processing and report may be given. Documents for association with vendors supplying LiDAR or better technology and GPR/ Induction Locator or better technology shall be furnished.

### C. Material testing, survey and investigation, equipment and software proposed to be used (20)

S. No.	Description	Maximum Points	Sub-Points
<b>1</b>	<b>Availability of in-house material testing facility</b>	<b>3</b>	
1.1	Available		<b>3</b>
1.2	Outsourced		
	(a) Through NABL accredited labs / IIT / NIT labs		2
	(b) Other than (a)		1

S. No.	Description	Maximum Points	Sub-Points
<b>2</b>	<b>Field Investigation Facilities</b>	<b>2</b>	
2.1	Available (Created in-house at site)		2
2.2	Outsourced		
	(a) Through NABL accredited labs / IIT / NIT labs		1
	(b) Other than (a)		0
<b>3</b>	<b>Office Equipment and Software</b>	<b>3</b>	
3.1	High Level (More than 75% as per ToR requirement)		<b>3</b>
3.2	Medium Level (Between 75%-50% as per ToR requirement)		2
3.3	Low Level (Less than 50% as per ToR requirement)		1
<b>4</b>	<b>Experience in LiDAR or better technology for topographic survey (Infrastructure sector)</b>	<b>5</b>	
4.1	1-2 projects		1
4.2	3-5 projects		2
4.3	6-10 projects		3
4.4	>10 projects		5
<b>5</b>	<b>Experience in using GPR and Induction Locator or better technologies for detection of sub-surface utilities (Infrastructure sector)</b>	<b>4</b>	
5.1	1-2 projects		1
5.2	3-5 projects		2
5.3	>5 projects		4
<b>6</b>	<b>Experience in digitization of cadastral maps for land surveys</b>	<b>3</b>	
6.1	Project of area upto 100 ha		1
6.2	Project of area between 100-500 ha		2
6.3	Project of area between 500 ha		3

**Note:** The experience of firm in LiDar or equivalent technology, GPR and Induction Locator or equivalent technologies and Experience in digitization of cadastral maps for land acquisition shall be supported by experience certificate. The experience of a firm in LiDar or equivalent technology, GPR and Induction Locator or equivalent technologies and Experience in digitization of cadastral maps for land acquisition for a private concessionaire/contractor shall be considered only if the experience certificate is authenticated by the concerned competent Government department/authority.

**D. Qualification and relevant experience of the proposed key personnel (50)**

The weightage for various key staff is as under:

S. No.	Key personnel	Points
1	Team Leader- cum Senior Bridge Engineer	15
2	Bridge Engineer	12
3	Senior Highway cum Pavement Engineer	12
4	Traffic / Road Signage / Marking and Safety Expert	11
	Total	50

The number of points assigned during the evaluation of qualification and competence of key staff are as given below:

S. No.	Description	Maximum Points	Sub-Points
<b>1</b>	<b>General Qualification</b>	<b>25</b>	
1.1	Essential education qualification		20
1.2	Desirable education qualification		5
<b>2</b>	<b>Relevant experience and adequacy for the project</b>	<b>70</b>	
2.1	Total professional experience		15
2.1	Experience in Highway Projects (Bridge Projects for Senior Bridge Engineer )		25
2.2	Experience in Similar Capacity		30
<b>3</b>	<b>Employment with the Firm</b>	<b>5</b>	
3.1	Less than 1 year		0
3.2	1 year to 2 years		2.5
3.3	> 2 years		5

- 12.3 Detailed evaluation criteria which is to be used for evaluation of technical bids is as indicated at Appendix-V.

The Consultant should carryout self-evaluation based on the evaluation criteria at Appendix-V. While submitting the self-evaluation along with bid, Consultant shall make references to the documents submitted in their proposal which have been relied upon in self-evaluation Result of technical evaluation shall be made available on the website giving opportunity to the bidders to respond within 7 days in case they have any objection

- 12.4 Third stage - Evaluation of Financial proposal

Financial Proposals of all Qualified Consultants in accordance with clause 5.2 and 5.3 of Letter of Invitation shall be opened.

The consultancy services will be awarded to the consultant scoring highest marks in combined evaluation of Technical and Financial proposals in accordance with clause 1.3 and 5.4 hereof.

The Factors are:

The weight given to Technical Proposal (T) = 0.80

The weight given to Financial Proposal (f) = 0.20

13. The common currency is “Indian Rupee”. (Ref. Para 3.3.3)

**Consultant have to quote in Rupees both for domestic Consultant as well as Foreign Consultants**

14. Commencement of Assignment (Date, Location): The Consultants shall commence the Services within fifteen days of the date of effectiveness of the contract at locations as required for the project stretch stated in TOR. (Ref. Para 1.2 of LOI and 2.3 of GCC/SC)

## APPENDIX I

### TERMS OF REFERENCE (TOR)

Consultancy Services for **Consultancy Services for Preparation of Feasibility Study and Detailed Project Report for:-**

- (i) 4-lane Elevated Section at Begusarai at Chainage 221.910 to 224.935 on NH-31, Length 3.025 Km
- (ii) 4-lane Elevated section of Shivala - Bihta section of Patna - Koilwar on NH-30 at design Chainage 16.050 to 29.500 of proposed alignment of NH-30, Length 13.450 Km
- (iii) 4-lane Elevated section at Gopalganj Chainage 384.483 to 386.362 on NH-28, Length 1.879 Km

#### Terms of Reference for Consultancy Services (TOR)

##### 1. General

1.1 The National Highways Authority of India (NHAI) has been entrusted with the assignment of

- (i) 4-lane Elevated Section at Begusarai at Chainage 221.910 to 224.935 on NH-31, Length 3.025 Km
- (ii) 4-lane Elevated section of Shivala - Bihta section of Patna - Koilwar on NH-30 at design Chainage 16.050 to 29.500 of proposed alignment of NH-30, Length 13.450 Km
- (iii) 4-lane Elevated section at Gopalganj Chainage 384.483 to 386.362 on NH-28, Length 1.879 Km

NHAI now invites proposal from Technical consultants for carrying out detailed project report as per details given in Annexure-1.

1.2 NHAI will be the employer and executing agency for the consultancy services and the standards of output required from the appointed consultants are of international level both in terms of quality and adherence to the agreed time schedule. The consultancy firm will solely be responsible for submission of quality work in stipulated period.

1.3 Ministry has recently awarded works of consultancy services for construction of ROBs for replacing level crossings in various states. In case a level crossing exists in a project reach, consultant is required to co-ordinate with those consultants and finalize the alignment & configuration of road accordingly. However, if the same is not covered in the above assignment of DPR/feasibility study awarded by Ministry, the consultant under this assignment shall be responsible for

preparing DPR for such level crossings.

## 2. Objective

- 2.1 The main objective of the consultancy service is to establish the technical, economical, and financial viability of the project and prepare detailed project reports for rehabilitation and upgrading of the existing road to <4 lane> configuration.
- 2.2 The viability of the project shall be established taking into account the requirements with regard to rehabilitation, upgrading and improvement based on highway design, pavement design, provision of service roads wherever necessary, type of intersections, rehabilitation and widening of existing and/or construction of new bridges and structures, road safety features, quantities of various items of works and cost estimates and economic analysis within the given time frame.
- 2.3 The Detailed Project Report (DPR) would inter-alia include detailed highway design, design of pavement and overlay with options for flexible or rigid pavements, design of bridges and cross drainage structures and grade separated structures, design of service roads, quantities of various items, detailed working drawings, detailed cost estimates, economic and financial viability analyses, environmental and social feasibility, social and environmental action plans as appropriate and documents required for tendering the project on commercial basis for international / local competitive bidding.
- 2.4 The DPR consultant should ensure detailed project preparation incorporating aspects of value engineering, quality audit and safety audit requirement in design and implementation. The Consultant shall ensure to carry out Road Safety Audit at various stages as per supplement-III (Additional Requirement for Safety Audit) of TOR.
- 2.5 The consultant should, along with Feasibility Report, clearly bring out through financial analysis the preferred mode of implementation on which the Civil Works for the stretches are to be taken up. The consultant should also give cost estimates along with feasibility report/ detailed Project Report.
- 2.6 If at inception stage or feasibility stage, employer desires to terminate the contract, the contract will be terminated after payment up to that stage.

## 3. Scope of Services

The general scope of services is given in the sections that follow. However, the entire scope of services would, inter-alia, include the items mentioned in the Letter of Invitation, terms of reference, general contract and any supplements and appendices to these documents.

### 3.1 RoW and Land related aspects

- 3.1.1 No land acquisition is involved in 4 lane elevated sections at Begusarai and Gopalganj. In Shivala Bihta efforts should be made to accommodate the alignment in available ROW and land acquisition if required may be kept as minimum.
- 3.1.2 Deleted
- 3.1.3 Deleted
- 3.1.4 Similarly, though it may be difficult, while determining the alignment for any bypass, efforts be made to see if these could be along the revenue boundaries of two revenue estates thereby minimizing the compulsions of land owners / farmers for cross-overs to the other side. In case such an alignment is not found feasible, it should be ensured that access to common facilities for the local people (e.g. schools, Healthcare facilities etc.) is maintained only on one side of the alignment, thereby minimizing the need for cross-over for day-to-day life.
- 3.1.5 Protection of the acquired RoW against any possible encroachments is extremely important. Boundary stones be provided at the end of the RoW as per Clause 9.8 of IRC:SP:84-2014 and also supplemented as per Circular dated 08.12.2015 issued by NHA. The boundary pillars alone, which are subject to removal with passage of time, may not be enough to save against encroachments. As such, the typical cross-section of a Highway Road is being re-visited separately with the intention of providing permanent features in this behalf. For a typical RoW of 60 mtrs, starting from one end, these will require the following:
- (a) Use barricading of the RoW with plantation of hedge-like species (Ficus / Poplars) within a 3m wide strip area, dug up to 0.6 to 0.9 mtrs, of which 2.0 mtrs to serve as a Utility Corridor.
  - (b) Provision of a Service Road (along the inhabited area) with its drainage slope towards the drain / area reserved for Strip Plantation, for a width of 9.0 mtrs.
  - (c) Earmark width of 1.5 mtrs for construction of a drain so as to be able to capture the rainwater flow from the Service Road (wherever provided) and the main carriageway.
  - (d) Three lane with paved shoulders: Main carriageway - 10.5 mtrs, paved shoulder - 1.5 mtr and earthen shoulder - 2.0 mtr (Total - 14 mtr).
  - (e) Median - 5.0 mtrs (effective width 4.5 m), and
  - (f) A Mirror Image on the other end.
- 3.2 Provisions of short bypasses, service roads, alignment corrections, improvement of intersections shall be made wherever considered necessary, practicable and cost effective. However, bypasses proposals should also be considered, wherever in



- urban areas, improvement to <lane> of the existing road is not possible.
- 3.3 The Consultant shall furnish land acquisition details as per revenue records/maps for further processing of land acquisition. Consultant shall also submit 3a, 3A and 3D draft notification for acquisition of land.
- 3.3.1 **Support in land Acquisition process till the receipt of land possession certificate from CALA**
- i. The Consultant shall identify all land parcels needing to be acquired as part of project RoW and shall furnish land acquisition details as per revenue records/maps for further processing of land acquisition.
  - ii. Assist CALA in preparation and verification of draft 3A/3D/3G/3H notifications, collecting information/documents, claims hearing etc.
  - iii. Liaison with state departments like land revenue department and registrar's office for collection and verification of revenue records, surveys, sale deeds, circle rates and for valuation of land related assets.
  - iv. Conduct all required surveys/valuation including joint measurement survey and valuation of land assets.
  - v. Support CALA by providing technical manpower (like Amins) clerical manpower and other resources (like vehicles, printers)
  - vi. Assist PIU in verification of 3A/3D/3G/3H drafts from CALA , drafting of documents (to be forwarded to RO/HQ), receipt of land possession certificate and in related activities till award of civil work
  - vii. Assist PIU in all official communications with CALA and other State department
- 3.4 **Approach to the provision and specifications for Structures:**
- 3.4.1 The structures on roads viz. Bridges, ROBs (Road Over Bridges, and Flyovers), RUBs (Road Under Bridges) etc. are designed for more than 50 years. It is difficult to increase the width of the structures at a later date which may also have larger financial implications apart from construction related issues in running traffic. Therefore, it has been decided to keep provision for all the structures including approaches comprising of retaining structures as 6-lane (length of such approaches shall, in no case, be less than 30m on either side) on all the four-lane highways except in the following cases (i) Reserve Forest (ii) Wild life Areas (iii) Hilly Areas (iv) Urban Areas where site condition do not permit this. Wherever elevated sections are designed through any inhabited areas, these should be six-lane structures supported on single piers so that the road underneath serves as effective service roads on both sides.
- 3.4.2 Highway projects shall be designed for separation of local traffic especially for Vulnerable Road Users (VRUs), for longitudinal movements and crossing facilities through viaduct(s) located at convenient walking distance. Provision of PUPs and CUPs with size of 7.0m x 3.0m, as specified in para 2.10 of the IRC specifications, has proved to be insufficient keeping in view the increased use of mechanization in agriculture practices. These structures do not support the easy passage / crossing for the tractors with trolleys so often used for agricultural operations. As traffic on cross roads is increasing day-by-day, it has been decided to substitute the provision of Pedestrian Underpass (PUP) / Cattle Underpass (CUP) [for para 2.10 of IRC specifies the dimensions of 7.0m x 3.0m] with a VUP Grade-II with a

minimum size of 12m (lateral clearance) x 4m (vertical clearance). Out of 12m lateral width, 2.5m width on one side shall be raised for pedestrian sidewalks with grills to make pedestrian movement convenient and safe. These structures shall be located at the most preferred place of pedestrian / cattle / day-to-day crossings. Depending on the site conditions, feasibility of clubbing the crossing facilities through service roads shall also be explored. Further, the bed level of these crossings shall not be depressed as any such depression, in the absence of proper drainage facilities becomes water-logged rendering the same unusable. Ideally, the bed level of the crossings should be a bit higher with proper connectivity to a drain, which could serve the drainage requirements of the main carriageway, the underpass and the service road as well.

- 3.4.3 Wherever the alignment of 4-lane Highway road project is retained in-situ while passing through inhabited areas (e.g. villages), it should be ensured that Service Roads are provided on both sides of the carriageway, connected underneath with a cross-over structure (VUP/PUP/CUP). Thus each habitation should preferably have crossing facility at the highways with a vertical clearance of 4 mtrs.
- 3.4.4 To ensure that bypass once constructed serves the intended purpose during its life, all the bypasses shall be well designed and access controlled. The entry / exit from / to side roads shall be controlled such that they are grade separated at major roads or at spacing not less than 5 kms. Side roads at closer spacing shall be connected to the service roads on either side and taken to major roads for provision of grade separated interchange.
- 3.5 The provision of embankments shall be kept minimum so as to save land as well as earth which are scarce resources. This can be decided on case to case basis with due deliberations. However, economic considerations may also be given due weightage before deciding the issue.
- 3.6 The Consultant shall study the possible locations and design of toll plaza if applicable to the project. Wayside amenities Land (minimum 5 acres, length and depth preferably in the ratio of 3:2) shall also be acquired for establishment of Way-side amenities at suitable locations at distances varying between 30 to 50 kms on both sides of the Highway. The local and slow traffic may need segregation from the main traffic and provision of service roads and fencing may be considered, wherever necessary to improve efficiency and safety.
- 3.7 The Consultant will also make suitable proposals for widening/improvement of the existing road and strengthening of the carriageways, as required at the appropriate time to maintain the level of service over the design period. The Consultants shall prepare documents for EPC/PPP contracts for each DPR assignment.
- 3.8 All ready to implement 'good for construction' drawings shall be prepared incorporating all the details.
- 3.9 Environmental Impact Assessment, Environmental Management Plan and Rehabilitation and Resettlement Studies shall be carried out by the Consultant meeting the requirements of the lending agencies like ADB/ World Bank/JICA, etc.

- 3.10 Wherever required, consultant will liaise with concerned authorities and arrange all clarifications. Approval of all drawings including GAD and detail engineering drawings will be got done by the consultant from the Railways. However, if Railways require proof checking of the drawings prepared by the consultants, the same will be got done by NHA and payment to the proof consultant shall be made by NHA directly. Consultant will also obtain final approval from Ministry of Environment and Forest for all applicable clearances. Consultant will also obtain approval for estimates for shifting of utilities of all types from the concerned authorities and NHA. Consultant is also required to prepare all Land Acquisition papers (i.e. all necessary schedule and draft 3a, 3A, and 3D, 3G notification as per L.A. act) for acquisition of land either under NH Act or State Act.
- 3.11 The DPR consultant may be required to prepare the Bid Documents, based on the feasibility report, due to exigency of the project for execution if desired by NHA.
- 3.12 Consultant shall obtain all types of necessary clearances required for implementation of the project on the ground from the concerned agencies. The client shall provide the necessary supporting letters and any official fees as per the demand note issued by such concerned agencies from whom the clearances are being sought to enable implementation.
- 3.13 The consultant shall prepare separate documents for BoT as well as EPC contracts at Feasibility stage / DPR stage. The studies for financing options like BoT, Annuity, EPC will be undertaken in feasibility study stage.
- 3.14 The consultant shall be guided in its assignment by the Model Concession/ Contract Agreements for PPP/ EPC projects, as applicable and the Manual of Specifications and Standards for two/ four/ six laning of highways published by IRC (IRC:SP:73 or IRC:SP:84 or IRC:SP:87, as applicable) along with relevant IRC codes for design of long bridges.
- 3.15 The consultant shall prepare the bid documents including required schedules (as mentioned above) as per EPC/ PPP documents. For that it is suggested that consultant should also go through the EPC/PPP documents of ministry before bidding the project. The Consultant shall assist the NHA and the Legal Adviser by furnishing clarifications as required for the financial appraisal and legal scrutiny of the Project Highway and Bid Documents.
- 3.16 Consultant shall be responsible for sharing the findings from the preparation stages during the bid process. During the bid process for a project, the consultant shall support the authority in responding to all technical queries, and shall ensure participation of senior team members of the consultant during all interaction with potential bidders including pre-bid conference, meetings, site visits etc. In addition, the consultant shall also support preparation of detailed responses to the written queries raised by the bidders.

#### **4. General**

##### **4.1 Primary Tasks**

General Scope of Services shall cover but be not limited to the following major

tasks (additional requirements for Preparation of Detailed Project Report for Hill Roads and Major Bridges are given in **Supplement I** and **II** respectively):

- i. Review of all available reports and published information about the project road and the project influence area;
- ii. Environmental and social impact assessment, including such as related to cultural properties, natural habitats, involuntary resettlement etc.
- ii (a). Public consultation, including consultation with Communities located along the road, NGOs working in the area, other stake-holders and relevant Government departments at all the different stages of assignment (such as inception stage, feasibility stage, preliminary design stage and once final designs are concretized).
- iii. Detailed Reconnaissance;
- iv. identification of possible improvements in the existing alignment and bypassing congested locations with alternatives, evaluation of different alternatives comparison on techno-economic and other considerations and recommendations regarding most appropriate option;
- v. traffic studies including traffic surveys and Axle load survey and demand forecasting for next thirty years;
- vi. Inventory and condition surveys for road;
- vii. Inventory and condition surveys for bridges, cross-drainage structures, other Structures, river Bank training/Protection works and drainage provisions;
- viii. Detailed topographic surveys using LiDAR equipped with minimum engineering grade system or any other better technology having output accuracy not less than (a) specified in IRC SP 19 (b) Total Station (c) GPS/ DGPS. The use of conventional high precision instruments i.e Total Station or equivalent can be used at locations such as major bypasses, water bodies etc. where it may not be possible to survey using LiDAR. Use of mobile / Aerial LiDAR survey is preferable.
- ix. Pavement investigations;
- x. Sub-grade characteristics and strength: investigation of required sub-grade and sub-soil characteristics and strength for road and embankment design and sub soil investigation;
- xi. Identification of sources of construction materials;
- xii. Detailed design of road, its x-sections, horizontal and vertical alignment and design of embankment of height more than 6m and also in poor soil conditions and where density consideration require, even lesser height embankment. Detailed design of structures preparation of GAD and

construction drawings and cross-drainage structures and underpasses etc.

- xiii. Identification of the type and the design of intersections;
  - xiv. Design of complete drainage system and disposal point for storm water
  - xv. Value analysis / value engineering and project costing;
  - xvi. Economic and financial analyses;
  - xvii. Contract packaging and implementation schedule.
  - xviii Strip plan indicating the scheme for carriageway widening, location of all existing utility services (both over- and underground) and the scheme for their relocation, trees to be felled, transplanted and planted and land acquisition requirements including schedule for LA: reports documents and drawings arrangement of estimates for cutting/ transplanting of trees and shifting of utilities from the concerned department;
  - xix Develop 3D engineered models of terrain and elevation, as-is project highway, proposed and project highway along with all features, current and proposed structures, current and proposed utilities and land acquisition plans.
  - xx To find out financial viability of project for implementation and suggest the preferred mode on which the project is to be taken up.
  - xxi. Preparation of detailed project report, cost estimate, approved for construction Drawings, rate analysis, detailed bill of quantities, bid documents for execution of civil works through budgeting resources.
  - xxii. Design of toll plaza and identification of their numbers and location and office cum residential complex including working drawings
  - xxiii. Design of weighing stations, parking areas and rest areas.
  - xxiv. Any other user oriented facility en-route toll facility.
  - xxv. Tie-in of on-going/sanctioned works of MORT&H/ NHAI/ other agencies.
  - xxvi. Preparation of social plans for the project affected people as per policy of the lending agencies/ Govt. of India R&R Policy.
- 4.2 While carrying out the field studies, investigations and design, the development plans being implemented or proposed for future implementation by the local bodies, should be taken into account. Such aspect should be clearly brought out in the reports and drawings.
- 4.3 The consultant shall study the possible locations and design of toll plaza, wayside amenities required and arboriculture along the highway shall also be

planned.

- 4.4 The local and slow traffic may need segregation from the main traffic and provision of service roads and physical barrier including fencing may be considered, wherever necessary to improve efficiency and safety.

#### 4.5 Standards and Codes of Practices

1. All activities related to field studies, design and documentation shall be done as per the latest guidelines/ circulars of MoRT&H and relevant publications of the Indian Roads Congress (IRC) and Bureau of Indian Standards (BIS). For aspects not covered by IRC and BIS, international standards practices, may be adopted. The Consultants, upon award of the Contract, may finalize this in consultation with NHAI and reflect the same in the inception report.
2. All notations, abbreviations and symbols used in the reports, documents and drawings shall be as per IRC:71.

#### 4.6 Quality Assurance Plan (QAP)

- 1.(i) The Consultants should have detailed Quality Assurance Plan (QAP) for all field studies including topographic surveys, traffic surveys, engineering surveys and investigations, design and documentation activities. The quality assurance plans/procedures for different field studies, engineering surveys and investigation, design and documentation activities should be presented as separate sections like engineering surveys and investigations, traffic surveys, material geo-technical and sub-soil investigations, road and pavement investigations, investigation and design of bridges & structures, environment and R&R assessment, economic & financial analysis, drawings and documentation, preparation, checking, approval and filing of calculations, identification and tractability of project documents etc. Further, additional information as per format shall be furnished regarding the details of personal who shall be responsible for carrying out/preparing and checking/verifying various activities forming part of feasibility study and project preparation, since inception to the completion of work. The detailed Draft QAP Document must be discussed and finalised with the concerned NHAI officers immediately upon the award of the Contract and submitted as part of the inception report.
- (ii) It is imperative that the QAP is approved by NHAI before the Consultants start the field work.
2. Data formats for report and investigation results
  - i. Required data formats for some reports, investigations and documents are discussed in Enclosure IV: Formats for submission of Reports and Documents.
  - ii. The consultants will need to propose data formats for use in all other field studies and investigations not covered in enclosure IV.

- iii. The proposed data forms will need to be submitted for the approval of NHAI after the commencement of services.

#### **4.7 Review of Data and Documents**

1. The Consultants shall collect the available data and information relevant for the Study. The data and documents of major interest shall include, but not be limited to, the following:
  - i. Climate;
  - ii. Road inventory
  - iii. Road condition, year of original construction, year and type of major maintenance/rehabilitation works;
  - iv. Condition of bridges and cross-drainage structures;
  - v. sub-surface and geo-technical data for existing bridges;
  - vi. Hydrological data, drawings and details of existing bridges;
  - vii. Existing geological maps, catchment area maps, contour plans etc. for the project area
  - viii. Condition of existing river bank / protection works, if any.
  - ix. Details of sanctioned / on-going works on the stretch sanctioned by MoRT&H/other agencies for Tie-in purposes
  - x. Survey and evaluation of locally available construction materials;
  - xi. Historical data on classified traffic volume (preferably for 5 years or more);
  - xii. Origin-destination and commodity movement characteristics; if available
  - xiii. Speed and delay characteristics; if available;
  - xiv. Commodity-wise traffic volume; if available;
  - xv. Accident statistics; and,
  - xvi. Vehicle loading behavior (axle load spectrum), if available.
  - xvii. Type and location of existing utility services (e.g. Fibre Optical Cable, O/H and U/G Electric, Telephone line, Water mains, Sewer, Trees etc.)
  - xviii. Environmental setting and social baseline of the project.

#### **4.8. Social Analysis**

The social analysis study shall be carried out in accordance with the MORT&H/World Bank/ADB Guidelines. The social analysis report will, among other things, provide a socio-economic profile of the project area and address in particular, indigenous people, communicable disease particularly HIV/AIDS poverty alleviation, gender, local population, industry, agriculture, employment, health, education, health, child labor, land acquisition and resettlement .

#### **4.9 Traffic Surveys**

All traffic surveys and studies will be completed in feasibility studies.

##### **4.9.1 Number and Location of Survey Stations**

1. The type of traffic surveys and the minimum number of survey stations shall normally be as under, unless otherwise specifically mentioned.

SI.NR.	Description	Number of Survey Stations
1.	Classified Traffic Volume Count	3
2.	Origin-Destination and Commodity Movement Characteristics	Minimum 2
3.	Axle Loading Characteristics	2
4.	Intersection Volume Count	All Major Intersections
5.	Speed-Delay Characteristics	Project Road Section
6.	Pedestrian/animal cross traffic count	All major inhabitations along the highway
7.	Turning movement surveys	For all major intersections

2. The number of survey locations indicated in the table above are indicative only for each road stretch under a package. The Consultants shall, immediately upon award of the work, submit to NHAI, proposals regarding the total number as well as the locations of the traffic survey stations as of inception report. Suitable maps and charts should accompany the proposals clearly indicating the rationale for selecting the location of survey Station.
3. The methodology of collection and analysis of data, number and location of traffic survey stations shall be finalized in consultation with NHAI prior to start of the traffic survey.

#### 4.9.2. Classified Traffic Volume Count Survey

1. Consultant shall make use of traffic survey done by Indian Highways Management Company Limited (IHMCL) using ATCC systems. However in isolated locations where there are site constraints, manual counting can be done. If required, especially in cases where a particular stretch is not covered by IHMCL, DPR consultant should carry out classified traffic volume count survey using ATCC systems or latest modern technologies.
2. Consultant shall use ATCC systems that can meet the following accuracy levels after validation/ calibration:
  - (a) Classification of vehicles: better than 95%
  - (b) Counting of vehicles: better than 98%

Before validation and calibration, the ATCC system shall meet the following accuracy levels:

- (a) Classification of vehicles: better than 90%
- (b) Counting of vehicles: better than 95%

For verification of above accuracy levels, audit of raw ATCC shall be done



by the consultant on a sampling basis and should submit a certificate in this regard.

3. ATCC systems such as Pneumatic Tube Detector, Inductive Detector Loop, Video Image Detection, and Infrared Sensor or latest technologies shall be adopted.
4. The classified traffic volume count surveys shall be carried out for 7 days (continuous, direction-wise) at the selected survey stations. The vehicle classification system as given in relevant IRC code may be followed. However, the following generalized classification system is suggested in view of the requirements of traffic demand estimates and economic analysis:

Motorised Traffic		Non-Motorised Traffic		
2-Wheeler		Bi-Cycle		
3-Wheeler		Cycle-Rickshaw		
Passenger Car		Animal Drawn Vehicle (ADV)		
Utility Vehicle (Jeep, Van etc.)		Hand Cart		
		Other Non-Motorised Vehicle		
Bus	Mini Bus Standard Bus			
LCV	LCV-Passenger LCV-Freight			
Truck	MCV : 2-Axle Rigid Chassis			
	HCV : 3-Axle Rigid Chassis			
	MAV			Semi Articulated
				Articulated

5. All results shall be presented in tabular and graphical form. The survey data shall be analyzed to bring out the hourly and daily variations. The traffic volume count per day shall be averaged to show a weekly average daily traffic (ADT) by vehicle type. The annual average daily traffic (AADT) shall be worked out by applying seasonal factors.
6. The consultant shall compile the relevant traffic volume data from secondary sources also. The salient features of traffic volume characteristics shall be brought out and variations if any, from the traffic census carried out by the State PWD shall be suitably explained.

#### 4.9.3. Origin Destination and Commodity Movements Surveys

1. The consultants shall carry out 1-day (24 hour, both directions) O-D and commodity movement surveys at locations finalized in consultation with NHAI. These will be essentially required around congested towns to

delineate through traffic. The road side interviews shall be carried out on random sample basis and cover all four-wheeled vehicles. The location of the O-D survey and commodity movement surveys shall normally be same as for the classified traffic count.

2. The location of origin and destination zones shall be determined in relation to each individual station and the possibility of traffic diversion to the Project Road from/to other road routes including bypasses.
3. The trip matrices shall be worked out for each vehicle type information on weight for trucks should be summed up by commodity type and the results tabulated, giving total weight and average weight per truck for the various commodity types. The sample size for each vehicle type shall be indicated on the table and also in the graphical representations.
4. The data derived from surveys shall also be analyzed to bring out the lead and load characteristics and desire line diagrams. The data analysis should also bring out the requirement for the construction of bypasses.
5. The distribution of lead and load obtained from the surveys should be compared. The axle load surveys shall normally be done using axle load pads or other sophisticated instruments. The location(s) of count station(s) and the survey with those derived from the axle load studies.
6. The commodity movement data should be duly taken into consideration while making the traffic demand estimates.

#### **4.9.4. Turning Movement Surveys**

1. The turning movement surveys for estimation of peak hour traffic for the design of major and minor intersections shall be carried out for the Study. The details regarding composition and directional movement of traffic shall be furnished by the Consultant.
2. The methodology for the surveys shall be as per IRC: SP: 41-1994. The details including location and duration of surveys shall be finalized in consultation with NHAI officials. The proposal in response to this TOR shall clearly indicate the number of locations that the Consultants wish to conduct turning movement surveys and the rationale for the same.
3. The data derived from the survey should be analyzed to identify requirements of suitable remedial measures, such as construction of underpasses, fly-overs, interchanges, grade-separated intersections along the project road alignment. Intersections with high traffic volume requiring special treatments either presently or in future shall be identified.

#### **4.9.5. Axle Load Surveys**

1. Axle load surveys in both directions shall be carried out at suitable

location(s) in the project road stretch on a random sample basis normally for trucks only (both empty and loaded trucks) for 2 normal days - (24 hours) at special count stations to be finalized in consultation with NHAI. However, a few buses may be weighed in order to get an idea about their loading behavior. While selecting the location(s) of axle load survey station(s), the locations of existing bridges with load restrictions, if any, should be taken into account and such sites should be avoided.

2. Axle load surveys shall normally be done using axle load pads or other sophisticated instruments. The location(s) of count station(s) and the survey methodology including the data formats and the instrument type to be used shall be finalized before taking up the axle load surveys
3. The axle load data should be collected axle configuration-wise. The number of equivalent standard axles per truck shall be calculated on the basis of results obtained. The results of the survey should bring out the VDF for each truck type (axle configuration, if the calculated VDF is found to be below the national average, then national average shall be used. Furthermore, the data from axle load surveys should be analyzed to bring out the Gross Vehicle Weight (GVW) and Single Axle Load (SAL) Distributions by truck type (axle configuration).
4. The Consultant shall ascertain from local enquiries about the exceptional live loads that have used the highway in the past in order to assess the suitability of existing bridges to carry such loads.

#### **4.9.6. Speed-Delay Surveys**

The Consultants shall carry out appropriate field studies such as moving car survey to determine running speed and journey speed. The data should be analyzed to identify sections with typical traffic flow problems and congestion. The objective of the survey would be to recommend suitable measures for segregation of local traffic, smooth flow of through traffic and traffic safety. These measures would include the provision of bypasses, under-passes, fly-overs, interchanges, grade-separated intersections and service roads.

#### **4.9.7 Pedestrian / animal cross traffic surveys:**

1. These shall be conducted to determine if provision of viaduct for pedestrians/animals is necessary to improve the traffic safety.
2. Consultant shall leverage information from local consultations, inputs from local governmental/ non-governmental agencies in selecting sites for checking pedestrian/ animal crossing traffic surveys.
3. Surveys for provision of pedestrian crossings shall minimum be conducted at all junctions being replaced by grade separators.

#### **4.9.8 Truck Terminal Surveys**

The data derived from the O-D, speed-delay, other surveys and also supplementary surveys should be analyzed to assess requirements for present

and future development of truck terminals at suitable locations en route.

#### **4.10. Traffic Demand Estimates**

1. The consultants shall make traffic demand estimates and establish possible traffic growth rates in respect of all categories of vehicles, taking into account the past trends, annual population and real per capita growth rate, elasticity of transport demand in relation to income and estimated annual production increase. The other aspects including socio-economic development plans and the land use patterns of the region having impact on the traffic growth, the projections of vehicle manufacturing industry in the country, development plans for the other modes of transport, O-D and commodity movement behavior should also be taken into account while working out the traffic demand estimates.
2. The values of elasticity of transport demand shall be based on the prevailing practices in the country. The Consultants shall give complete background including references for selecting the value of transport demand elasticity.
3. It is envisaged that the project road sections covered under this TOR would be completed and opened to traffic after 3 years. The traffic demand estimates shall be done for a further period of 30 years from completion of two/four lane. The demand estimates shall be done assuming three scenarios, namely, optimistic, pessimistic and most likely traffic growth. The growth factors shall be worked out for five-yearly intervals.
4. Traffic projections should be based on sound and proven forecasting techniques. In case traffic demand estimated is to be made on the basis of a model, the application of the model in the similar situation with the validation of the results should be established. The traffic projections should also bring out the possible impact of implementation of any competing facility in the near future. The demand estimates should also take into account the freight and passenger traffic along the major corridors that may interconnect with the project. Impact of toll charges on the traffic estimates should be estimated.
5. The methodology for traffic demand estimates described in the preceding paragraphs is for normal traffic only. In addition to the estimates for normal traffic, the Consultants shall also work out the estimates for generated, induced and diverted traffic.
6. The traffic forecasts shall also be made for both diverted and generated traffic.
7. Overall traffic forecast thus made shall form the basis for the design of each pavement type and other facilities/ancillary works.

#### **4.11. Engineering Surveys and Investigations**

##### **4.11.1. Reconnaissance and Alignment**

1. The Consultants should make an in-depth study of the available land width (ROW) topographic maps, satellite imageries and air photographs of the project area, geological maps, catchment area maps, contour plans, flood flow data and seismological data and other available relevant information collected by them concerning the existing alignment. Consultant himself has to arrange the required maps and the information needed by him from the potential sources. Consultant should make efforts for minimizing land acquisition. Greater use of technology for LA be adopted by the consultant at the DPR stage so as to have a precise land acquisition process.
2. The detailed ground reconnaissance may be taken up immediately after the study of maps and other data. The primary tasks to be accomplished during the reconnaissance surveys include;
  - i. topographical features of the area;
  - ii. typical physical features along the existing alignment within and outside ROW i.e. land use Pattern;
  - iii. possible alignment alternatives, vis-a-vis, scheme for the construction of additional lanes parallel to the existing road;
  - iv. realignment requirements including the provision of bypasses, ROBs / Flyovers and via-duct for pedestrian crossings with possible alignment alternatives;
  - v. preliminary identification of improvement requirements including treatments and measures needed for the cross-roads;
  - vi. traffic pattern and preliminary identification of traffic homogenous links;
  - vii. sections through congested areas;
  - viii. inventory of major aspects including land width, terrain, pavement type, carriageway type, bridges and structures (type, size and location), intersections(type, cross-road category, location) urban areas (location, extent), geologically sensitive areas, environmental features:
  - ix. critical areas requiring detailed investigations; and,
  - x. Requirements for carrying out supplementary investigations.
  - xi. soil (textural classifications) and drainage conditions
  - xii. Type and extent of existing utility services along the alignment (within ROW).
  - xiii. Typical physical features along the approach roads
  - xiv. Possible bridge locations, land acquisition problems, nature of crossings, likely length of approaches and bridge, firmness of banks, suitability of alignment of approach roads.
3. The data derived from the reconnaissance surveys are normally utilized for planning and programming the detailed surveys and investigations. All field studies including the traffic surveys should be taken up on the basis of information derived from the reconnaissance surveys.
4. The data and information obtained from the reconnaissance surveys should be documented. The data analysis and the recommendations concerning alignment and the field studies should be included in the

Inception Report. The data obtained from the reconnaissance surveys should form the core of the database which would be supplemented and augmented using the data obtained from detailed field studies and investigations.

5. The data obtained from the reconnaissance surveys should be compiled in the tabular as well as graphical (chart) form indicating the major physical features and the proposed widening scheme for NHAI's comments. The data and the charts should also accompany the rationale for the selection of traffic survey stations.

#### 4.11.2. Topographic Surveys

1. The basic objective of the topographic survey would be to capture the essential ground features along the alignment in order to consider improvements and for working out improvements, rehabilitation and upgrading costs. The detailed topographic surveys should normally be taken up after the completion of reconnaissance surveys.
2. The carrying out of topographic surveys will be one of the most important and crucial field tasks under the project. Technologies which can meet the following accuracy levels shall be adopted. For land based surveys (a) Fundamental horizontal accuracy of 5cm or better (b) Fundamental vertical accuracy of 5cm or better (c) More than 50 points shall be measured per sq. m and for aerial based surveys (a) Fundamental horizontal accuracy of 5 cm or better (b) Fundamental vertical accuracy of 5 cm or better (c) More than 10 points shall be measured per sq. m. To establish accuracy, a check point survey using DGPS (for horizontal accuracy) and Auto Level (for vertical accuracy) shall be carried out to establish the fundamental horizontal and vertical accuracy. A minimum of 25 check points, or check points once every 4 km should be established, and these should be strictly different from any geo-referencing or control network points.
3. The following are the set of deliverables which should be submitted after completion of survey:
  - (a) Raw DGPS data for the entire highway length and adjoining areas of interest
  - (b) Point cloud data or equivalent for the entire highway length and adjoining areas of interest in a format/ platform as per industry good practice which shall be amenable to operations by NHAI/ Consultant. NHAI may decide about format/ platform of point cloud data
  - (c) Topographic map of scale 1:1000 of the entire highway length and adjoining areas of interest
  - (d) Contour map of 50 cm of entire highway length and adjoining areas of interest

- (e) Cross section of the highway at every 50 m in drawing format.
  - (f) Develop a digital elevation/surface model (bare earth model from survey data) digital terrain model combining topographic data from LiDAR, road inventory and other available sources of data for use while modeling the road alignment and road and structure design.
4. For land based surveys, Mobile LiDAR (Light Detection and Ranging) or better technology that can meet above requirements shall be adopted. For aerial based surveys, Aerial Mobile LiDAR (Light Detection and Ranging) or better technology that can meet above requirements shall be adopted. Where possible, mobile/terrestrial LiDAR and total station or better studies should be used to supplement aerial LiDAR for the final alignment chosen. Aerial based surveys shall be used as the primary source of topographical data only in cases where a new/green field alignment is being planned and/or major junctions are being planned where it is necessary to significantly increase the survey corridor beyond the capabilities of mobile LiDAR. In shadow areas such as invert levels below culverts, terrestrial LiDAR shall be used where LiDAR or better technologies cannot survey accurately, traditional methods of Total Station/ Auto Level shall be used to complete the study.
  5. In case of mobile LiDAR or better technology, 360 degree panoramic images of the entire highway length and adjoining areas of interest shall be submitted. In case of aerial LiDAR or better technology, ortho-images of the entire highway length and adjoining areas of interest shall be submitted.
  6. The detailed field surveys would essentially include the following activities:
    - i. Topographic Surveys along the Existing Right of Way (ROW): Carrying out topographic survey using LiDAR or better technology along the existing road and realignments, wherever required and properly referencing the same with reference pillars fixed on either side of the centre-line at safe places within the ROW
    - ii. The detailed field surveys would essentially include the topographic surveys along the proposed location of bridge and alignment of approach road.
    - iii. The detailed topographic surveys should be carried out along the approach roads alignment and location of bridge approved by NHAI.
    - iv. Collection/ Extraction of details for all features such as structures (bridges, culverts etc.) utilities, existing roads, electric and telephone installations (both O/H as well as underground), huts, buildings, fencing and trees (with girth greater than 0.3metre) oil and gas lines etc. falling within the extent of survey.
  7. The width of survey corridor will generally be as given under:

- i. The width of the survey corridor should take into account the layout of the existing alignment including the extent of embankment and cut slopes and the general ground profile. While carrying out the field surveys, the widening scheme (i.e. right, left or symmetrical to the centre line of the existing carriageway) should be taken into consideration so that the topographic surveys cover sufficient width beyond the centre line of the proposed divided carriageway. Normally the surveys should extend a minimum of 30 m beyond either side of the centre line of the proposed divided carriageway or land boundary whichever is more
  - ii. In case the reconnaissance survey reveals the need for bypassing the congested locations, the traverse lines would be run along the possible alignments in order to identify and select the most suitable alignment for the bypass. The detailed topographic surveys should be carried out along the bypass alignment approved by NHAI. At locations where grade separated intersections could be the obvious choice, the survey area will be suitably increased. Field notes of the survey should be maintained which would also provide information about traffic, soil, drainage etc.
  - iii. The width of the surveyed corridor will be widened appropriately where developments and / or encroachments have resulted in a requirement for adjustment in the alignment, or where it is felt that the existing alignment can be improved upon through minor adjustments.
  - iv. Where existing roads cross the alignments, the survey will extend a minimum of 100 m either side of the road centre line and will be of sufficient width to allow improvements, including at grade intersection to be designed.
8. The surveyed alignment shall be transferred on to the ground as under:
- i. Reference Pillar and Bench Mark / Reference pillar of size 15 cm X 15 cm X 45cm shall be cast in RCC of grade M 15 with a nail fixed in the centre of the top surface. The reference pillar shall be embedded in concrete upto a depth of 30cm with CC M10 (5 cm wide all around). The balance 15 cm above ground shall be painted yellow. The spacing shall be 250m apart, incase Bench Mark Pillar coincides with Reference Pillar, only one of the two need be provided.
  - ii. Establishing Bench marks at site connected to GTS Bench marks at a interval of 250 metres on Bench mark pillar made of RCC as mentioned above with RL and BM No. marked on it with red paint.
  - iii. **Boundary Pillars-** Wherever the proposed alignment follows the existing alignment, the boundary pillars shall be fixed by the DPR consultant at an interval of 200m on either side of proposed Right of Way. Wherever there is a proposal of realignment of the existing Highway and/or construction of New Bypasses, Consultant shall fix boundary pillars along the proposed alignment on the extreme boundary on either side of the project Highway at 50 m interval. Boundary pillars shall be strictly



provided as per IRC:25:1967.

#### **4.11.2.1 Longitudinal and Cross-Sections**

The topographic surveys for longitudinal and cross-sections shall cover the following:

- i. Longitudinal section levels along final centre line shall be taken at every 10 m interval. The levels shall be taken at closer intervals at the curve points, small streams, and intersections and at the locations of change in elevation. The interval shall also be modified as per IRC:SP-19 for rolling, mountainous & steep terrain.
  - ii. Cross sections at every 50 m interval in full extent of survey covering sufficient number of spot levels on existing carriageway and adjacent ground for profile correction course and earth work calculations. Cross sections shall be taken at closer interval at curves. The interval shall be modified as per IRC SP 19 for rolling, mountainous & steep terrain.
  - iii. Longitudinal section for cross roads for length adequate for design and quantity estimation purposes.
  - iv. Longitudinal and cross sections for major and minor streams shall cover Cross section of the channel at the site of proposed crossing and few cross sections at suitable distance both upstream and downstream, bed level upto top of banks and ground levels to a sufficient distance beyond the edges of channel, nature of existing surface soil in bed, banks & approaches, longitudinal section of channel showing site of bridge etc. These shall be as per recommendations contained in IRC Special Publication No. 13 (Guidelines for the Design of Small Bridges and Culverts) and provisions of IRC:5 (“Standard Specifications & Code of Practice for Road Bridges, Section 1 - General Features of Design”).
2. At feasibility study stage cross sections at 50m interval may be taken.
  3. Consultants shall also develop an as-is map of the road including:
    - i. Geo-referenced digital map of as-is project highway
    - ii. Earth surface, road layers, utilities, buildings and trees with feature data extracted and mapped in layers, marked on the map and tabulated data provided separately.
    - iii. All road, surface, sub surface inventory, pavement investigation and soil survey data to be super-imposed as layers using geo-referencing data

#### **4.11.2.2 Details of utility Services and Other Physical Features**

1. The Consultants shall collect details of all important physical features along the alignment. These features affect the project proposals and should normally include buildings and structures, monuments, burial grounds, cremation grounds, places of worship, railway lines, stream / river / canal, water mains, sewers, gas/oil pipes, crossings, trees,

plantations, utility services such as electric, and telephone lines (O/H & U/G) and poles, optical fibre cables (OFC) etc. The survey would cover the entire right-of-way of the road on the adequate allowance for possible shifting of the central lines at some of the intersections locations.

2. Consultant shall also map out sub-surface utilities. Accurate mapping and resolution of all sub-surface utilities up to a depth of 4 m shall be carried out. Differentiation between sub-surface utilities such as live electric cables, metallic utilities and other utilities shall be indicated and sub-surface utilities radargrams further processed into utility maps in formats such as PDF, JPEG and AutoCAD shall be furnished. To meet the accuracy levels, consultant shall use Ground Penetrating Radar, Induction Locator or better technologies.
3. The information collected during reconnaissance and field surveys shall be shown on a strip plan so that the proposed improvements can be appreciated and the extent of land acquisition with LA schedule, utility removals of each type etc. assessed and suitable actions can be initiated. Separate strip plan for each of the services involved shall be prepared for submission to the concerned agency.

#### **4.11.3. Road and Pavement Investigations**

The Consultants shall carry out detailed field studies in respect of road and pavement. The data collected through road inventory and pavement investigations should be sufficient to meet the input requirements of HDM-IV.

##### **4.11.3.1 Road Inventory Surveys**

1. Detailed road inventory surveys shall be carried out to collect details of all existing road and pavement features along the existing road sections. The inventory data shall include but not limited to the following:
  - i. Terrain (flat, rolling, mountainous);
  - ii. Land-use (agricultural, commercial, forest, residential etc) @ every kilometre;
  - iii. Carriageway width, surfacing type @ every 500m and every change of feature whichever is earlier;
  - iv. Shoulder surfacing type and width @ every 500m and every change of feature whichever is earlier;
  - v. Sub-grade / local soil type (textural classification) @ every 500m and every change of feature whichever is earlier;
  - vi. Horizontal curve; vertical curve
  - vii. Road intersection type and details, at every occurrence;

- viii. Retaining structures and details, at every occurrence;
  - ix. Location of water bodies (lakes and reservoirs), at every occurrence;
  - x. Height of embankment or depth of cut @ every 200m and every change of feature whichever is earlier.
  - xi. Land width i.e. ROW
  - xii. Culverts, bridges and other structures (type, size, span arrangement and location)
  - xiii. Roadside arboriculture
  - xiv. Existing utility services on either side within ROW. There shall be a provision of utility corridor for appropriate categories / combination of utilities in the construction of new 4/6 laning of National Highways. Such structures shall be located at appropriate location preferably as close to the extreme edge of Right of Way (RoW). In this connection, guidelines contained in IRC:98 shall be followed.
  - xv. General drainage conditions
  - xvi. Design speed of existing road
2. The data should be collected in sufficient detail. The data should be compiled and presented in tabular as well as graphical form. The inventory data would be stored in computer files using simple utility packages, such as EXCEL.

#### **4.11.3.2 Pavement Investigation**

- 1. Pavement Composition**
  - i. The data concerning the pavement composition may be already available with the PWD. However, the consultants shall make trial pits to ascertain the pavement composition. The test pit interval will be as per Para 4 below.
  - ii. For each test pit, the following information shall be recorded:
    - test pit reference (Identification number, location):
    - pavement composition (material type and thickness); and
    - subgrade type (textural classification) and condition (dry, wet)
    - embankment (composition and geometry)

## 2. Road and Pavement Condition Surveys

- i. Detailed field studies shall be carried out to collect road and pavement surface conditions. The data should generally cover:
  - pavement condition (surface distress type and extent);
  - shoulder condition;
  - embankment condition; and
  - drainage condition

### Pavement Condition

- cracking (narrow and wide cracking), % of pavement area affected;
- raveling, % of pavement area affected;
- potholing, % of pavement area affected;
- edge break, length (m); and,
- rut depth, mm

### Shoulder Condition

- Paved: Same as for pavement
- Unpaved: material loss, rut depth and corrugation,
- Edge drop, mm.

### Embankment Condition

- general condition; and
  - extent of slope erosion
- ii. The objective of the road and pavement condition surveys shall be to identify defects and sections with similar characteristics. All defects shall be systematically referenced, recorded and quantified for the purpose of determining the mode of rehabilitation.
  - iii. In addition to visual means, the pavement condition surveys shall be carried out using Network Survey vehicles mounted with equipments such as high resolution cameras, digital laser profilometer, transverse profiler- the data from which should be geo-referenced using a DGPS receiver and in vehicle data processing software or equivalent technology to accurately measure the pavement surface properties covered earlier. This pavement condition survey shall also be used as a repository for civil work and shall be carried out as per the directions of NHAI.
  - iv. Supplemented by actual measurements and in accordance with the widely accepted methodology (AASHTO, IRC, OECD, TRL and World Bank Publications) adapted to meet the study requirements. The measurement of rut depth would be made using standard straight edges.
  - v. The shoulder and embankment conditions shall be evaluated by visual means and the existence of distress modes (cuts, erosion marks, failure,

- drops) and extent (none, moderate, frequent and very frequent) of such distress manifestations would be recorded.
- vi. For sections with severe distresses, additional investigations as appropriate shall be carried out to determine the cause of such distresses.
  - vii. Middle 200m could be considered as representative sample for each one km. of road and incase all other things are considered similar.

### **Drainage Condition**

- General condition
- Connectivity of drainage turnouts into the natural topography
- Condition in cut sections
- Condition at high embankments

The data obtained from the condition surveys should be analyzed and the road segments of more or less equal performance may be identified using the criteria given in IRC: 81-1997.

### **3. Pavement Roughness**

- i. The roughness surveys shall be carried out using a network survey vehicle mounted laser profilometer or better technology with specifications as described in para 2 above
- i(a) In addition, the following criteria should be met by the process of defect detection:
  - Roughness measurement with outputs of both raw longitudinal profiles and IRI calculation shall be reported at 100m referenced to the preceding LRP. The roughness must meet ASTM-E950 (equivalent to Class I road profiler).
  - The IRI shall be determined for both wheelpaths over a minimum length of 250m for a minimum of 6 calibration sites with a roughness range between 2m/km and 8m/km. Calibration shall be made for speeds of 20, 30, 40, 50, 60 km/h.
- ii. The surveys shall be carried out along the outer wheel paths. The surveys shall cover a minimum of two runs along the wheel paths for each direction.
- iii. The results of the survey shall be expressed in terms of BI and IRI and shall be presented in tabular and graphical forms. The processed data shall be analyzed using the cumulative difference approach to identify road segments homogenous with respect to surface roughness.

### **4. Pavement Structural Strength**

- 2 **The Consultants shall carry out structural strength surveys for existing pavements using Falling Weight Deflectometer metre (FWD) in accordance with IRC 115 or IRC 117 as the case may be.**

- i. It is suggested that the deflection surveys may be carried out as per the scheme given below:
  - mainline testing; and,
  - Control section testing.
- ii. The deflection tests for the mainline shall be carried out at every 500 m along the road sections covered under the study. The control section testing shall involve carrying out deflection testing for each 100 m long homogenous road segment along the road sections. The selection of homogenous segment shall be based on the data derived from pavement condition surveys. The total length of such homogenous segments shall not be less than 100 m per kilometre. The deflection measurements for the control section testing should be at an interval of not more than 10 m.
- iii. Test pits shall be dug at every 500 m and also along each homogeneous road segment to obtain pavement composition details (pavement course, material type and thickness) so as to be able to study if a correlation exists between deflection and composition. If so, the relationship may be used while working out the overlay thickness for the existing pavement.
- iv. Falling weight deflectometre surveys may not be carried out for severely distressed sections of the road warranting reconstruction. The Consultants, immediately upon the award of the contract, shall submit to NHAI the scheme describing the testing schedule including the interval. The testing scheme shall be supported by data from detailed reconnaissance surveys.
- v. It is mandatory for the consultant to use Falling weight deflectometre or alternative better technique for the evaluation of pavement strength, details of such methods or innovative features for deflection testing using Falling weight deflectometre along with the methodology for data analysis, interpretation and the use of such data for pavement overlay design purposes using IRC or any other widely used practices, such as AASHTO guidelines, should be got approved by NHAI. The sources of such methods should be properly referenced.

#### **4.11.3.3 Subgrade Characteristics and Strength**

1. Based on the data derived from condition (surface condition, roughness) and structural strength surveys, the project road section should be divided into segments homogenous with respect to pavement condition and strength. The delineation of segments homogenous with respect to roughness and strength should be done using the cumulative difference approach (AASHTO, 1993).
2. The data on soil classification and mechanical characteristics for soils along the existing alignments may already be available with the PWD. The testing scheme is, therefore, proposed as given under:
  - i. For the widening (2-Laning) of existing road within the ROW, the

Consultants shall test at least three sub-grade soil samples for each homogenous road segment or three samples for each soil type encountered, whichever is more.

- ii. For the roads along new alignments, the test pits for sub grade soil shall be @5km or for each soil type, whichever is more. A minimum of three samples should be tested corresponding to each homogenous segment.
3. The testing for subgrade soil shall include:
  - i. in-situ density and moisture content at each test pit
  - ii. Field CBR using DCP at each test pit
  - iii. Characterization (grain size and Atterberg limits) at each test pit and,
  - iv. Laboratory moisture-density characteristics (modified AASHTO compaction);
  - v. Laboratory CBR (unsoaked and 4-day soak compacted at three energy levels) and swell.
4. For problematic soils, the testing shall be more rigorous. The characteristics with regard to permeability and consolidation shall also be determined for these soils. The frequency of sampling and testing of these soils shall be finalized in consultation with the NHAI officers after the problematic soil types are identified along the road sections.
5. The laboratory for testing of material should be got approved from NHAI before start of work.

#### **4.11.4 Investigations for Bridges and Structure**

##### **4.11.4.1 Inventory of Bridges, Culverts and Structures**

The Consultants shall make an inventory of all the structures (bridges, viaducts, ROBs/RUB and other grade separated structures, culverts, etc.) along the road under the project. The inventory for the bridges, viaducts and ROBs shall include the parameters required as per the guidelines of IRC-SP:35. The inventory of culverts shall be presented in a tabular form covering relevant physical and hydraulic parameters.

##### **4.11.4.2 Hydraulic and Hydrological Investigations**

1. The hydrological and hydraulic studies shall be carried out in accordance with IRC Special Publication No. 13 (“Guidelines for the Design of Small Bridges and Culverts”) and IRC:5 (“Standard Specifications & Code of Practice for Road Bridges, Section I General Feature of Design”). These investigations shall be carried out for all existing drainage structures along the road sections under the study.
2. The consultant shall also collect information on observed maximum depth of scour.
3. In respect of major bridges, history of hydraulic functioning of existing bridge, if any, under flood situation, general direction of river course through structure, afflux, extent and magnitude of flood, effect of backwater, if any, aggradation/degradation of bed, evidence of scour etc. shall be used to augment the available hydrological data. The presence of flood control/ irrigation structures, if affecting the hydraulic characteristics like causing obliquity, concentration of flow, scour, silting of bed, change in flow levels, bed levels etc. shall be studied and considered in design of bridges. The details of any future planned work that may affect the river hydraulics shall be studied and considered.
4. The Consultants shall make a desk study of available data on topography (topographic maps, stereoscopic aerial photography), storm duration, rainfall statistics, top soil characteristics, vegetation cover etc. so as to assess the catchment areas and hydraulic parameters for all existing and proposed drainage provisions. The findings of the desk study would be further supplemented and augmented by a reconnaissance along the area. All-important hydrological features shall be noted during this field reconnaissance.
5. The Consultants shall collect information on high flood level (HFL), low water levels (LWL), high tide level (HTL), low tide level (LTL) where applicable, discharge velocity etc. from available past records, local inquiries and visible signs, if any, on the structural components and embankments. Local inquiries shall also be made with regard to the road sections getting overtopped during heavy rains.



6. Conducting Model studies for bridges is not covered in the scope of consultancy services. If Model study is envisaged for any bridge, requirement of the same shall be spelt out in the RPF documents separately indicating scope and time frame of such study. Salient features of the scope of services to be included for model study are given in the supplement- II Terms of Reference.

#### **4.11.4.3 Condition Surveys for Bridges, Culverts and Structures**

1. The Consultants shall thoroughly inspect the existing structures and shall prepare a report about their condition including all the parameters given in the Inspection pro-forma of IRC-SP:35. The condition and structural assessment survey of the bridges / culverts / structures shall be carried out by senior experts of the Consultants.
2. For the bridges identified to be in a distressed condition based upon the visual condition survey, supplementary testing shall be carried out as per IRC-SP:35 and IRC-SP:40. Selection of tests may be made based on the specific requirement of the structure.
3. The assessment of the load carrying capacity or rating of existing bridges shall be carried out under one or more of the following scenarios:
  - i. when the design live load is less than that of the statutory commercial vehicle plying or likely to ply on bridge;
  - ii. if during the condition assessment survey and supplementary testing the bridge is found to indicate distress of serious nature leading to doubt about structural and / or functional adequacy, and
  - iii. Design live load is not known nor are the records and drawings available
4. The evaluation of the load carrying capacity of the bridge shall be carried out as per IRC-SP:37 (“Guidelines for Evaluation of Load Carrying Capacity of Bridges”). The analytical and correlation method shall be used for the evaluation of the load carrying capacity as far as possible. When it is not possible to determine the load carrying capacity of the bridge using analytical and correlation method, the same shall be carried out using load testing. The consultant has to exhaust all other methods of evaluation of strength of bridges before recommending to take up load testing of bridges. Road closure for testing if unavoidable shall be arranged by NHAI for limited duration say 12 hours or so.
5. Consultant shall carryout necessary surveys and investigations to establish the remaining service life of each retainable bridge or structure with and without the proposed strengthening and rehabilitation according to acceptable international practice in this regard.

#### 4.11.4.4 Geo-technical Investigations and Sub-Soil Exploration

1. The Consultants shall carry out geo-technical investigations and sub-surface explorations for the proposed Bridges / Road over bridges/ tunnels/ viaducts/ interchanges etc., along high embankments and any other location as necessary for proper design of the works and conduct all relevant laboratory and field tests on soil and rock samples. The minimum scope of geo-technical investigations for bridge and structures shall be as under:

S. No.	Description	Location of Boring
1	Overall length = 6 – 30 m	One abutment location and at least one intermediate location between abutments for structures having more than one span
2	<b>Overall length = 30 – 60 m</b>	One abutment location and at least one intermediate location between abutments for structures having more than one span.
3	Overall length >60 m	Each abutment and each pier locations.

2. The deviation(s), if any, by the Consultants from the scheme presented above should be approved by NHAI.
3. However, where a study of geo-technical reports and information available from adjacent crossings over the same waterway (existing highway and railway bridges) indicates that subsurface variability is such that boring at the suggested spacing will be insufficient to adequately define the conditions for design purposes, the Consultants shall review and finalize the bore hole locations in consultation with the NHAI officers.
4. Geotechnical Investigations and Sub soil Explorations shall be carried out to determine the nature and properties of existing strata in bed, banks and approaches with trial pits and bore hole sections showing the levels, nature and properties of various strata to a sufficient depth below the level suitable for foundations, safe intensity of pressure on the foundation strata, proneness of site to artesian conditions, seismic disturbance and other engineering properties of soil etc. Geotechnical investigation and Sub-soil Exploration will be done as per IRC 78.
5. The scheme for the borings locations and the depth of boring shall be prepared by the Consultants and submitted to NHAI for approval. These may be finalized in consultation with NHAI.
6. The sub-soil exploration and testing should be carried out through the Geotechnical Consultants empanelled by MORT&H. The soil testing reports shall be in the format prescribed in relevant IRC Codes.



7. For the approach road pavement, bore holes at each major change in pavement condition or in deflection readings or at 2 km intervals whichever is less shall be carried out to a depth of at least 2 m below embankment base or to rock level and are to be fully logged. Appropriate tests to be carried out on samples collected from these bore holes to determine the suitability of various materials for use in widening of embankments or in parts of new pavement structure.

#### 4.11.5. Material Investigations

1. The Consultants shall identify sources (including use of fly-ash/ slag), quarry sites and borrow areas, undertake field and laboratory testing of the materials to determine their suitability for various components of the work and establish quality and quantity of various construction materials and recommend their use on the basis of techno-economic principles. The Consultants shall prepare mass haul diagram for haulage purposes giving quarry charts indicating the location of selected borrow areas, quarries and the respective estimated quantities.

“Environment friendly materials”

“As per MORTH circular No. RW /NH-33044/53/2013-S&R(R) dated 20<sup>th</sup> November, 2013, alternative pavement materials and technologies for road construction shall be assessed and compared in the design stage. The alternative resulting in substantial reduction in GHG emission and with least life cycle cost shall be recommended for implementation.

Technical and economic feasibility of using industrial byproducts, recyclable and waste materials shall be assessed depending on their availability in the concerned region.

2. It is to be ensured that no material shall be used from the right-of-way except by way of leveling the ground as required from the construction point of view, or for landscaping and planting of trees etc. or from the cutting of existing ground for obtaining the required formation levels.
3. Environmental restrictions, if any, and feasibility of availability of these sites to prospective civil works contractors, should be duly taken into account while selecting new quarry locations.
4. The Consultants shall make suitable recommendations regarding making the borrow and quarry areas after the exploitation of materials for construction of works.
5. The Material Investigation aspect shall include preparation and testing of bituminous mixes for various layers and concrete mixes of different design mix grades using suitable materials (binders, aggregates, sand filler etc.) as identified during Material Investigation to conform to latest MoRT&H specification.

## 4.12 Detailed Design of Road and Pavements, Bridges, Structures

### 4.12.1. General

1. The Consultants are to carryout detailed designs and prepare working drawings for the following:
  - i. High speed highway with divided carriageway configuration complete in all respects with service roads at appropriate locations;
  - ii. Design of pavement for the additional lanes and overlay for the existing road, paved shoulders, medians, verges;
  - iii. Bridges, viaduct/subways and other grade separated structures including ROBs/RUBs etc.
  - iv. At-grade and grade-separated intersections, interchanges (if required);
  - v. ROB for railway crossings as per the requirement and the standards of the Indian Railways; and,
  - vi. Prepare alignment plans, longitudinal sections and cross-sections@ 50mintervals;
  - vii. Designs for road furniture and road safety/traffic control features;
  - viii. Designs and drawings for service road/under passes/overpass / cattle passes tree planting/fencing at locations where necessary / required
  - ix.. Toll plazas and office-cum-residential complex for PIU (one for each civil contract package)
  - x Short bypasses at congested locations
  - xi. Drainage design showing location of turnouts, out falling structures, separate drawings sheet for each 5 km. stretch.
  - xii. Bridges and structures rehabilitation plan with design and drawings
  - xiii. Traffic amenities (Parking Areas, Weighing Station and Rest Areas, etc.).
  - xiv Design of pavement for approach road
  - xv Design of river bank protection / training works. Innovative type of structures with minimum joints, aesthetically, pleasing and appropriate to the topography of the region shall be designed wherever feasible.

#### **4.12.2. Design Standards**

1. The Consultants shall evolve Design Standards and material specifications for the Study primarily based on IRC publications, MoRT&H Circulars and relevant recommendations of the international standards for approval by NHAI.
2. The Design Standards evolved for the project shall cover all aspects of detailed design including the design of geometric elements, pavement design, bridges and structures, traffic safety and materials.

#### **4.12.3. Geometric Design**

1. The design of geometric elements shall, therefore, take into account the essential requirements of such facilities.
2. Based on the data collected from reconnaissance and topographic surveys, the sections with geometric deficiencies, if any, should be identified and suitable measures for improvement should be suggested for implementation.
3. The data on accident statistics should be compiled and reported showing accident type and frequency so that black spots are identified along the project road section. The possible causes (such as poor geometric features, pavement condition etc.) of accidents should be investigated into and suitable cost-effective remedial measures suggested for implementation.
4. The detailed design for geometric elements shall cover, but not be limited to the following major aspects:
  - i. horizontal alignment;
  - ii. longitudinal profile;
  - iii. cross-sectional elements, including refuge lane (50m) at every 2kms.
  - iv. junctions, intersections and interchanges;
  - v. bypasses; and,
  - vi. service roads as and when require i.e built up area..
5. The alignment design shall be verified for available sight distances as per the standard norms. The provision of appropriate markings and signs shall be made wherever the existing site conditions do not permit the adherence to the sight distance requirements as per the standard norms.

6. The consultants shall make detailed analysis of traffic flow and level of service for the existing road and workout the traffic flow capacity for the improved project road. The analysis should clearly establish the widening requirements with respect to the different horizon periods taking into account special problems such as road segments with isolated steep gradients.
7. In the case of closely spaced cross roads the Consultant shall examine different options such as, providing grade separated structure for some of them with a view to reduce number of at-grade crossings, services roads connecting the cross-roads and closing access from some of the intersections and prepare and furnish appropriate proposals for this purpose keeping in view the cost of improvement, impact on traffic movement and accessibility to cross roads. The detailed drawings and cost estimate should include the provisions for realignments of the existing cross roads to allow such arrangements.
8. The Consultant shall also prepare design of grade separated pedestrian crossings (viaducts) for large cross traffic of pedestrians and / or animals on the basis of passenger and animal cross traffic surveys conducted.
9. The Consultant shall also prepare details for at-grade junctions, which may be adopted as alternative to the grade separated structures. The geometric design of interchanges shall take into account the site conditions, turning movement characteristics, level of service, overall economy and operational safety.
10. The Consultants shall prepare design and other details in respect of the parallel service roads in urbanized locations and other locations to cater to the local traffic, their effect of the viability of the project on commercial basis if service roads are constructed as part of the project and the implications of not providing the service roads.
11. The consultant shall prepare complete road and pavement design including drainage for new bypass option identified around congested town en-route.

#### **4.12.4. Pavement Design**

1. The detailed design of pavement shall involve:
  - i. strengthening of existing road pavement and design of the new pavement if any, if the findings of the traffic studies and life-cycle costing analysis confirm the requirement for widening of the road beyond 2lane undivided carriageway standard;;
  - ii. pavement design for bypasses; and,

- iii. design of shoulders.
- 2. The design of pavement shall primarily be based on IRC publications.
- 3. The design of pavement shall be rigorous and shall make use of the latest Indian and International practices. **The design alternatives shall include both rigid and flexible design options. The most appropriate design, option shall be established on life-cycle costing and techno-economic consideration.**
- 4. For the design of pavement, each set of design input shall be decided on the basis of rigorous testing and evaluation of its suitability and relevance in respect of in-service performance of the pavement. The design methodology shall accompany the design proposals and shall clearly bring out the basic assumptions, values of the various design inputs, rationale behind the selection of the design inputs and the criteria for checking and control during the implementation of works. In other words, the design of pavement structure should take due account of the type, characteristics of materials used in the respective courses, variability of their properties and also the reliability of traffic predictions. Furthermore, the methodology adopted for the design of pavement shall be complete with flowcharts indicating the various steps in the design process, their interaction with one another and the input parameter required at each step.
- 5. For the design of overlays for the existing 2-lane pavement, the strengthening requirement shall duly take into account the strength of the existing pavement vis-à-vis the remaining life. The overlay thickness requirements shall be worked out for each road segment homogenous with respect to condition, strength and sub-grade characteristics. The rehabilitation provisions should also include the provision of regulating layer. For existing pavement with acceptable levels of cracking, provision of a crack inhibiting layer should also be included.
- 5 (a) For rehabilitation and strengthening, consultant shall consider the alternatives of rehabilitating the existing pavement, overlaying with the same or alternate pavement type (e.g. white/black topping) and also the option of removal and replacement of existing pavement layers and chose the best alternative basis lifecycle costing, and any local considerations such as material availability, time available for construction etc.
- 6. Latest techniques of pavement strengthening like provision of geosynthetics and cold/hot pavement recycling should be duly considered by the consultant for achieving economy. The use of technology particularly environment friendly technology viz. recycling of bituminous mixes, warm mixes and soil stabilization etc. should be adopted wherever feasible. Clause 519 of the “Specifications for Road and Bridge Works” (Fifth Revision) covers specifications for recycling of existing bituminous pavement materials to upgrade the pavements. These provisions notwithstanding, recycling of existing bituminous materials is yet to be implemented in most of the NHAI projects. The reclaiming and



reprocessing of pavement materials involve both design (how the pavement should be designed using reclaimed materials with the given properties) and technology (the methods to reclaim and reprocess, equipment, knowhow and quality) issues. After addressing these issues, the recycling of pavements will be environmentally and economically better option for rehabilitation, repair or reconstruction compared to the use of fresh or virgin materials. Indian Road Congress has published IRC: 120-2015 on “recommended practice for recycling of bituminous pavements” giving a detailed procedure for its implementation

7. The paved shoulders shall be designed as integral part of the pavement for the main carriageway. The design requirements for the carriageway pavement shall, therefore, be applicable for the design of shoulder pavements. The design of granular shoulder should take into account the drainage considerations besides the structural requirements.
8. The pavement design task shall also cover working out the maintenance and strengthening requirements and periodicity and timing of such treatments.

#### 4.12.5. Design of Embankments

1. The embankments design should provide for maximum utilization of locally available materials consistent with economy. Use of fly ash wherever available with in economical leads must be considered. In accordance with Government instructions, **use of fly ash within 300 km from Thermal Power Stations is mandatory** as per extra ordinary Gazette Notification No. S.O. 254 (E) Part Section - III - Sub Section (ii) dated 25<sup>th</sup> January, 2016 and subsequent amendment, if any of Ministry of Environment, Forest and Climate change, New Delhi.
2. The Consultants shall carry out detailed analysis and design for all embankments of height greater than 6 m based on relevant IRC publications.
3. The design of embankments should include the requirements for protection works and traffic safety features.

#### 4.12.6. Design of Bridges and Structures

1. The data collected and investigation results shall be analyzed to determine the following:
  - i. HFL
  - ii. LWL
  - iii. LBL
  - iv. Erodibility of bed/scour level
  - v. Design discharge
  - vi. Linear waterway and effective linear waterway
  - vii. Likely foundation depth

- viii. Safe bearing capacity
  - ix. Engineering properties of sub soil
  - x. Artesian conditions
  - xi. Settlement characteristics
  - xii. Vertical clearance
  - xiii. Horizontal clearance
  - xiv. Free board for approach road
  - xv. Severity of environment with reference to corrosion
  - xvi. Data pertaining to seismic and wind load
  - xvii. Requirement of model study etc.
2. The Consultant shall prepare General Arrangement Drawing (GAD) and Alignment Plan showing the salient features of the bridges and structures proposed to be constructed / reconstructed along the road sections covered under the Study. These salient features such as alignment, overall length, span arrangement, cross section, deck level, founding level, type of bridge components(superstructure, substructure, foundations, bearings, expansion joint, return walls etc.) shall be finalized based upon hydraulic and geo-technical studies, cost effectiveness and ease of construction. The GAD shall be supplemented by Preliminary designs. In respect of span arrangement and type of bridge a few alternatives with cost-benefit implications should be submitted to enable NHAI to approve the best alternative. After approval of alignment and GAD the Consultant shall prepare detailed design as per IRC codes /guidelines and working drawings for all components of bridges and structures.
  3. The location of all at-grade level crossings shall be identified falling across the existing level crossings for providing ROB at these locations. The Consultants shall prepare preliminary GAD for necessary construction separately to the Client. The Consultant shall pursue the Indian Railways Authorities or/and any statutory authority of State/Central Government for approval of the GAD from concerned Authorities.
  4. GAD for bridges/structures across irrigation/water way channels shall be got approved from the concerned Irrigation/Water way Authorities. Subsequent to approval of GAD and alignment plan by NHAI, the Consultants shall prepare detailed design as per IRC codes/guidelines for all components of the bridges and structures.
  5. Subsequent to the approval of the GAD and Alignment Plan by NHAI and Railways, the Consultant shall prepare detailed design as per IRC and Railways guidelines and working drawings for all components of the bridges and structures. The Consultant shall furnish the design and working drawings for suitable protection works and/or river training works wherever required.
  6. Dismantling/ reconstruction of existing structures shall be avoided as far as possible except where considered essential in view of their poor structural conditions/ inadequacy of the provisions etc.

7. The existing structures having inadequate carriageway width shall be widened/reconstructed in part or fully as per the latest MoRT&H guidelines. The Consultant shall furnish the detailed design and working drawings for carrying out the above improvements.
8. Suitable repair / rehabilitation measures shall be suggested in respect of the existing structures as per IRC-SP:40 along with their specifications, drawings and cost estimate in the form of a report. The rehabilitation or reconstruction of the structures shall be suggested based on broad guidelines for rehabilitation and strengthening of existing bridges contained in IRC-SP:35 and IRC-SP:40.
9. Subsequent to the approval of the GAD and the alignment plan by NHAI, detailed design shall also be carried out for the proposed underpasses, overpasses and interchanges.
10. The Consultants shall also carry out the design and make suitable recommendations for protection works for bridges and drainage structures.
11. In case land available is not adequate for embankment slope, suitable design for RCC retaining wall shall be furnished. However, RES wall may also be considered depending upon techno-economic suitability to be approved by NHAI.
12. All the bridge structures having a length of 100 m or less can be used for tapping of water for serving dual purpose i.e., to cross the water body or to store water, if technically feasible. Therefore, such structures shall be designed as bridge cum barrage structures (bridge cum bandhara). Ministry's guidelines in this regard issued vide letter no. RW/NH-34066/89/2015-S&R(B) dated 18.04.2017 may be referred.

#### **4.12.7. Drainage System**

1. The requirement of roadside drainage system and the integration of the same with proposed cross-drainage system shall be worked out for the entire length of the project road section.
2. In addition to the roadside drainage system, the Consultants shall design the special drainage provisions for sections with super-elevated carriageways, high embankments and for road segments passing through cuts. The drainage provisions shall also be worked out for road segments passing through urban areas.
3. The designed drainage system should show locations of turnouts/outfall points with details of outfall structures fitting into natural contours. A separate drawing sheet covering every 5 km. stretch of road shall be prepared.

4. The project highway shall be designed to have well designed efficient drainage system, which shall be subsurface, as far as possible. While constructing the underpasses, the finished road level shall be determined so as to ensure that the accumulation of rain water does not take place and run-off flows at the natural ground level. The drains, wherever constructed, shall be provided with proper gradient and connected to the existing outlets for final disposal.
5. The rain water harvesting requirements be assessed taking into consideration the Ministry of Environment & Forest Notification Dt. 14.01.1997 (as amended on 13.01.1998, 05.01.1999 & 06.11.2000). The construction of rainwater harvesting structure is mandatory in and around water scarce / crisis areas notified by the Central Ground Water Board. The provisions for rainwater harvesting be executed as per the requirements of IRC:SP:42-2014 (Guidelines for Road Drainage) and IRC:SP:50-2013 (Guidelines on Urban Drainage).
6. All the bridge structures having a length of 100m or less can be used for tapping of water for serving dual purpose i.e. to cross the water body and to store water, if technically feasible. Therefore, such structures should be designed as bridge cum barrage structures (bridge cum bandhara). Ministry's guidelines in this regard issued vide letter no. RW/NH-34066/59/2015-S&R(B) dated 18.04.2017 may be referred.
7. The locations of the culverts should be planned in such a way that the proposed culvert covers optimum catchment area & the location shall be decided on the basis of topographical survey, local rainfall data, gradient of natural ground and enquiry from the local habitants. All culverts should preferably be box culverts as pipe culverts get filled up with silt, which is rarely cleared.

#### **4.12.8. Traffic Safety Features, Road Furniture and Road Markings**

1. The Consultants shall design suitable traffic safety features and road furniture including traffic signals, signs, markings, overhead sign boards, crash barriers, delineators etc. The locations of these features shall be given in the reports and also shown in the drawings.
2. The Consultant should make the provisions for "the overhead (gantry-mounted) signs on roads with two or more lanes in the same direction" as per provisions of IRC-67. The minimum height of gantry mounted sign be 5.5 m above the highest point at the carriageway.
3. Road safety shall be the focus of design. The roads shall be forgiving, having self-explaining alignment, safe designed intersections / interchanges segregation and safe crossing facilities for VRUs with crash barriers at hazardous locations. The details of traffic signs and pavement markings with their locations, types and configuration shall be shown on the plan so that they are correctly provided.

4. DPR shall undergo the exercise of Road Safety Audit through the Road Safety Auditor (separate from design team) and recommendations mentioned be incorporated.
5. Road markings and proper signage constitute another important aspect of the Road safety. The DPR shall contain a detailed signage plan, indicating the places, directions, distances and other features, duly marked on the chainage plan. It shall specify the suitable places where FoBs are to be provided. Road marking and signage plan shall be included in DPR and shall be specifically approved by the NHAI.
6. Advanced Traffic Management System (ATMS) shall be in place for all 4/6 lane roads of NHAI being put to tolling. This would provide real time information, guidance and emergency assistance to users. ATMS would include outdoor equipment including emergency call boxes, variable message sign systems, meteorological data system, close circuit TV camera (CCTV) system in addition to any other equipment required to meet the objective. Indoor equipment would include large display board, central computer with Network Management System, CCTV monitor system and management of call boxes system with uninterrupted power supply, all housed in a central control centre. In this connection, NHAI's policy circular no.11041/218/2007-Admn dated 15.09.2016 may be referred.
7. As availability of suitable sight distance has a large effect on road safety, the alignment of all the NHs should be finalized in such a way so as to have double the stopping sight distance available to the road users at all locations.

#### **4.12.9. Arboriculture and Landscaping**

The Consultants shall work out appropriate plan for planting of trees (specifying type of plantation), horticulture, floriculture on the surplus land of the right-of way with a view to beautify the highway and making the environment along the highway pleasing. These activities should be included in the TOR for contractor/concessionaire and the cost of these activities shall also be added to the total project cost for civil works. The existing trees / plants shall be retained to the extent possible. The Transplantation of trees shall also be proposed wherever feasible.

#### **4.12.10. Toll Plaza**

1. The Consultants shall identify the possible toll plaza location(s) based on the data and information derived from the traffic studies and a study of the existing physical features including the availability of land. The location of the plaza should keep in view that the project road is to be developed as a partially access controlled highway facility and it is required to collect toll on rational basis from as much of the vehicular traffic as possible consistent with economy of collection and operations. The location of the toll plaza should be finalized in consultation with NHAI.

2. The minimum number of toll lanes at the toll plazas should be carefully designed taking into consideration the projected peak hour tollable traffic, permissible service time, adopted toll collection system and the capacity of service lanes. The number of lanes at any toll plaza would, however, be not less than four times the number of lanes for which the highway has been designed. Eventually, all the lanes have to be designed / equipped with Electronic Toll Collection (ETC) systems and one lane at the extreme outer side for Over Dimensioned Vehicles (ODV) should be earmarked in each direction.
3. Car lanes and lanes for commercial vehicles shall be earmarked at the toll plaza with outer lanes earmarked for the commercial vehicles. At least 50% of the total lanes on each side shall be equipped with weigh-in-motion facility for dedicated use by commercial vehicles followed by a static weigh bridge on either side. Number of lanes with weigh-in-motion facility may be suitably increased depending on proportion of commercial vehicles in total traffic. Provision should be kept for acquisition and earmarking of about one acre area for parking of the overloaded vehicles.
4. Toll Plaza shall be designed as per IRC 84.

#### **4.12.11. Weighing Station, Parking Areas and Rest Areas**

1. The consultant shall select suitable sites for weighing stations, parking areas and rest areas and prepare suitable separate designs in this regard. The common facilities like petrol pump, first-aid medical facilities, police office, restaurant, vehicle parking etc. should be included in the general layout for planning. For petrol pump, the guidelines issued by OISD of Ministry of Petroleum shall be followed. The facilities should be planned to be at approximately 50 km interval. At least each facility (1 no.) is foreseen to be provided for this project stretch. Weighing stations can be located near toll plazas so that overloaded vehicles can be easily identified and suitably penalized and unloaded before being allowed to proceed further. The type of weighing system suitable for the project shall be brought out in the report giving merits of each type of the state-of-the art and basis of recommendations for the chosen system.
2. The Consultant should take into consideration the provisions for persons with disabilities (PwD) in way side amenity centres / rest areas and provide ramp facilities, exit / entrance door with minimum clear opening of 900 mm and special toilet facilities for use of handicapped persons. The consultant shall also take into consideration, the provisions for Pedestrians facilities as per IRC-103.

#### **4.12.12 Miscellaneous Works**

1. The Consultants shall make suitable designs and layout for miscellaneous works including rest areas, bus bays, vehicle parking areas, telecommunication facilities etc. wherever appropriate.

2. The Consultants shall prepare the detailed scheme and lay out plan for the works mentioned in Para 1.
3. The Consultants shall prepare detailed plan for the traffic management and safety during the construction period.

#### **4.13 Environment and Social Impact Assessment**

The consultant shall under take the detailed environmental and social impact assessment in accordance with the standard set by the Government of India for projects proposed to be funded by MORT&H/NHAI. In respect of projects proposed to be funded by ADB loan assistance, Environmental Assessment Requirements, Environmental Guidelines for selected infrastructure projects, 1993 of Asian Development Bank shall be followed. Similarly, for projects proposed to be funded by World Bank loan assistance, World Bank Guidelines shall be followed.

##### **4.13.1 Environmental Impact Assessment**

Environment impact assessment or initial environment examination be carried out in accordance with ADB's Environmental Assessment Requirements of ADB 1998 guidelines for selected infrastructure projects 1993 as amended from time to time /World Bank Guidelines / Government of India Guidelines, as applicable

1. The consultant should carry out the preliminary environmental screening to assess the direct and induced impacts due to the project.
2. The consultant shall ensure to document baseline conditions relevant to the project with the objective to establish the benchmarks.
3. The consultant shall assess the potential significant impacts and identify the mitigation measures to address these impacts adequately.
4. The consultant shall do the analysis of alternatives incorporating environmental concerns. This should include with and without scenario and modification incorporated in the proposed project due to environment considerations.
5. The consultant shall give special attention to the environmental enhancement measures in the project for the following:
  - (a) Cultural property enhancement along the highways
  - (b) Bus bays and bus shelters including a review of their location,
  - (c) Highway side landscape and enhancement of the road junctions,
  - (d) Enhancement of highway side water bodies, and
  - (e) Redevelopment of the borrow areas located on public land.

6. The consultant shall prepare the bill-of-quantities (BOQ) and technical specifications for all items of work in such a way that these may be readily integrated to the construction contracts.
7. The consultant shall establish a suitable monitoring network with regard to air, water and noise pollution. The consultant will also provide additional inputs in the areas of performance indicators and monitoring mechanisms for environmental components during construction and operational phase of the project.
8. The consultant shall provide the cost of mitigation measures and ensure that environmental related staffing, training and institutional requirements are budgeted in project cost.
9. The consultant shall prepare the application forms and obtain forestry and environmental clearances from the respective authorities including the SPCBs and the MOEF on behalf of NHAI. The consultants will make presentation, if required, in defending the project to the MOEF Infrastructure Committee.
10. The consultant shall identify and plan for plantation and Transplantation of the suitable trees along the existing highway in accordance with IRC guidelines.
11. The consultant shall assist in providing appropriate input in preparation of relevant environment and social sections of BPIP.
12. Provision should be made for Noise Barriers wherever (especially where project highway passes through dense habitation) required as a mitigation measure against noise pollution and nuisance. Their location, dimension, type, material and shapes should be determined and defined in environment impact assessment studies forming part of DPR.



#### 4.13.2 Social Assessment

- 1 The consultant would conduct base line socio-economic and census survey to assess the impacts on the people, properties and loss of livelihood. The socioeconomic survey will establish the benchmark for monitoring of R&R activities. A social assessment is conducted for the entire project to identify mechanisms to improve project designs to meet the needs of different stakeholders. A summary of stakeholder discussions, issue raised and how the project design was developed to meet stakeholders need would be prepared.
- 2 The consultant shall prepare Land Acquisition Plan and assist NHAI in acquisition of land under various Acts.

#### 4.13.3

The consultant would prepare Resettlement and Rehabilitation Plan and assess feasibility and effectiveness of income restoration strategies and suitability and availability to relocation sites. The resettlement plan which accounts for land acquisition and resettlement impacts would be based on a 25% socio-economic survey and 100 % census survey of project affected people which provides the complete assessment of the number of affected households and persons, including common property resources. All untitled occupants are recorded at the initial stages and identify cards will be issued to ensure there is no further influx of people in to the project area. All consultations with affected persons (to include list of participants) should be fully documented and records made available to NHAI.

- Assessment on the impact of the project on the poor and vulnerable groups along the project road corridor.
- Based on the identified impacts, developing entitlement matrix for the project affected people.
- Assessment on social issues such as indigenous people, gender, HIV/AIDS, labourers including child labour.
- Implementation budgets, sources and timing of funding and schedule of tasks.
- Responsibility of tasks, institutional arrangements and personnel for delivering entitlement and plans to build institutional capacity.
- Internal and external monitoring plans, key monitoring indicators and grievance redress mechanism.
- Incorporating any other suggestions of the ADB/ World Bank/ NHAI, till the acceptance of the reports by the ADB/ World Bank/ NHAI

#### 4.13.4 Reporting Requirements of EIA

- The consultant would prepare the stand-alone reports as per the requirement of the ADB/World Bank /NHAI, as applicable, with contents as per the following:
- Executive Summary
- Description of the Project
- Environmental setting of the project.

- Identification and categorization of the potential impacts (during pre- construction, construction and operation periods).
- Analysis of alternatives (this would include correlation amongst the finally selected alternative alignment/routing and designs with the avoidance and environmental management solutions).
- The public consultation process.
- Policy, legal and administrative framework. This would include mechanisms at the states and national level for operational policies. This would also include a description of the organizational and implementation mechanism recommended for this project.
- Typical plan or specific designs for all additional environmental items as described in the scope of work.
- Incorporating any other as per the suggestions of the ADB/ World Bank / NHAI, till the acceptance of the reports by the ADB/ World Bank /NHAI, as applicable.
- EMP Reports for Contract Package based on uniform methodology and processes. The consultant will also ensure that the EMP has all the elements for it to be a legal document. The EMP reports would include the following:
  - Brief description of the project, purpose of the EMP, commitments on incorporating environmental considerations in the design, construction and operations phases of the project and institutional arrangements for implementing the EMP.
  - A detailed EMP for construction and operational phases with recourse to the mitigation measures for all adverse impacts.
  - Detailed plans for highway-side tree plantation (as part of the compensatory afforestation component).
  - Environmental enhancement measure would be incorporated.
  - Enhancement measures would include items described in the scope of work and shall be complete with plans, designs, BOQ and technical specifications.
  - Environmental monitoring plans during and after construction including scaling and measurement techniques for the performance indicators selected for monitoring.
  - The EMP should be amendable to be included in the contract documents for the works.
  - Incorporating any other as per the suggestions of the ADB/ World Bank/ NHAI, till the acceptance of the reports by the ADB/ World Bank /NHAI as applicable.

#### 4.13.5 Reporting requirements of RAP

Analysis on the resettlement plan be conducted based on ADBs Hand Book on Resettlement, A Guide to Good practice 1998 as amended time to time/ World Bank Guidelines / Government of India Guidelines, as applicable.

- Executive summary
- Description of project
- Objectives of the project.
- The need for Resettlement in the Project and evaluation of measures to minimize resettlement.

- Description and results of public consultation and plans for continued participation of PAPs.
- Definition of PAPs and the eligibility criteria.
- Census and survey results-number affected, how are they affected and what impacts will they experience.
- Legal and entitlement policy framework-support principles for different categories of impact.
- Arrangements for monitoring and evaluation (internal and external)
- Implementation schedule for resettlement which is linked to the civil works contract
- A matrix of scheduled activities linked to land acquisition procedures to indicate clearly what steps and actions will be taken at different stages and the time frame
- The payment of compensation and resettlement during the acquisition process
- An itemized budget (replacement value for all assets) and unit costs for different assets

## **5.1 Land acquisition process**

### **5.1.1 Conduct all required surveys/valuation**

1. Identify all land parcels that need to be acquired as part of project road
2. Conduct Joint measurement survey in conjunction with CALA, NHAI and Land revenue department to verify land records.
3. Conduct valuation of land related assets (Structures, trees, crops etc.) and liaison with respective State authority for authentication of the valuation

### **5.1.2 Digitization of cadastral maps**

1. Consultants shall procure or create digitised, geo-referenced cadastral/land revenue maps for the purposes of land acquisition activities.
2. Where state governments or local agencies have already digitised cadastral maps, the consultant shall arrange to acquire these maps.
3. For acquired maps, the consultant shall check and verify the level of accuracy in the maps and their suitability for the purposes of supporting the land acquisition effort for the project road in terms of both dimensional accuracy and details available.
4. Where digitised land maps are unavailable or are deemed to be insufficient for the purposes of this project, the consultant shall digitize the cadastral/land revenue maps of the area falling in and surrounding the existing and proposed road RoW, keeping the following in mind:
  - i. The digitized map shall exactly match the original map, like a contact print, in the dimensions and area of plots, or the whole village is to be extracted from the map itself.
  - ii. An accuracy of 1mm or higher in a 1:1000 scale map shall be ensured, as this translates into an accuracy of 1 m or higher on ground.
  - iii. In addition, ground control points will be used to adjust the digitized map to exactly match the ground situation.
  - iv. Geo-location information from the control points should be added to the digitized map to allow for import into a GIS system. Suitable land details and features should also be added to the GIS system to enable review of individual land parcels.

- v. In digitization and feature addition, the consultant shall endeavor to follow any standards, requirements and formats laid down by the relevant state/ central government agency for land ownership and revenue management or that set by the authority involved in digitization of land records.
- 5. Where applicable, the consultant must then share back the digitised cadastral maps with the relevant local agency or state government.

#### **5.1.3 Liaison with relevant state departments throughout process**

- 1. The consultant should liaison with State' departments including but not limited to Land Revenue Office (or Tehsil), Registrar office and with other State departments (like Public works department, horticulture department etc.) to expedite the Land acquisition process.
- 2. The consultant should co-ordinate collection of all the necessary land record documents and information required to support CALA/CALA staff during the LA process.

#### **5.1.4 Facilitate communication between NHAI (PIU) and CALA**

- 1. The consultant should ensure prompt official communication (including delivery of documents) between Competent Authority for Land Acquisition (CALA) and NHAI.

#### **5.1.5 Support CALA with manpower and resources**

- 1. The consultant should provide adequate technically qualified manpower including but not limited to ex -Amin/Surveyor or equivalent and ex-Land Revenue Inspector or equivalent - to support Competent Authority of Land Acquisition (CALA) / CALA staff in the LA process corresponding to respective project. The engagement of retired Revenue Officer with Team (Kanoongo/ Girdawar or equivalent and Patwari) should be in such a way that one Revenue officer be responsible for 100 km length of DPR or part thereof. These support staff shall be deployed until 3(E), G and H are completed.
- 2. The consultant should provide adequate clerical manpower like assistant, peon, computer operator as required to support CALA/CALA staff in the LA process corresponding to respective project.
- 3. The consultant should provide adequate resources including vehicles, laptop/desktop, and stationeries as required to support CALA/CALA staff in the LA process corresponding to respective project.

#### **5.1.6 Assist NHAI (PIU) and CALA in the publishing of 3A notification**

- 1. Provide copy of 3a notification to CALAs and District Collector
- 2. Co-ordinate collection all the relevant land revenue records (including Khasra maps, khatiyani, Jamabandi etc.) from land revenue department required for preparation of 3A draft
- 3. Prepare and submit 3A draft and LA plan in the format prescribed by NHAI
- 4. Co-ordinate submission of copies of LA plan and Alignment map to CALA offices through PIU required for verification of 3A draft
- 5. Facilitate CALA staff in verification of the draft 3A version
- 6. Assist CALA staff in preparation of 3A notification, preamble and forwarding letter to be forwarded to PIU
- 7. Co-ordinate delivery of 3A notification (declared by CALA) along with preamble and forwarding letter to PIU

8. Assist PIU in preparing 3A notification (English & Hindi version) and corresponding check-list documents in format prescribed to be sent for approval to NHAI HQ

#### **5.1.7 Assist CALA and NHAI (PIU) in the publishing of 3D notification**

1. Provide copy of 3A Gazette notification to CALA
2. Support CALA staff to draft 3C notification and 3A notification to be published in 2 newspapers : 1 Vernacular + 1 other
3. Co-ordinate with NHAI/CALA on publishing of 3C and 3A notifications in 2 local newspapers - 1 vernacular and 1 other
4. Provide copies of newspaper publication of 3C and 3A notification to the CALA
5. Assist CALA staff in receiving and compiling of public objections
6. Co-ordinate with CALA for scheduling public hearings
7. Assist CALA staff for sending notices to petitioners on respective hearing dates
8. Assist CALA during objection hearings, recording of hearings , ensuring compliance of corresponding orders and notification of final CALA order to petitioners
9. Plant boundary stones/peg-marking along the alignment
10. Conduct Joint measurement survey in conjunction with CALA, NHAI and Land revenue department to verify land records. Prepare and submit Joint Measurement Survey Report along with updated alignment sketches of each survey and village to PIU
11. Co-ordinate collection of all relevant land records including but not limited to Khatiyaan, Jamabandi, Chakbandi and other relevant records required for preparation of 3D draft
12. Prepare draft 3D based on JMS report and collected records
13. Co-ordinate submission of draft 3D to CALA office through PIU
14. Assist CALA staff in verification of draft 3D and preparation of draft 3D declared
15. Assist CALA staff in preparation of draft 3D notification, preamble and forwarding letter to be forwarded to PIU
16. Co-ordinate delivery of 3D notification (declared by CALA) along with preamble and forwarding letter to PIU
17. Assist PIU in verification of 3D notification (declared by CALA)
18. Assist PIU in preparing Draft 3D (English & Hindi version) and corresponding check-list documents in format prescribed to be sent for approval to NHAI HQ

#### **5.1.8 Assist the CALA in the declaration of award (3G)**

1. Provide copy of 3D Gazette notification to CALA.
2. Assist CALA in drafting public notice inviting claims (under sub-section 3 of section 3G) from all persons interested in the land to be acquired and 3D notification to be published in 2 local newspaper - 1 vernacular and 1 other.
3. Co-ordinate with NHAI/CALA on publishing of 3D and claim invitation notification in 2 local newspapers - 1 vernacular and 1 other.
4. Provide 1 copy of newspaper notification of 3D and claim invitation to CALA, Ward, Panchayat, Circle office, police station and Collector office.

5. Assist CALA during claim hearings, record hearings and compliance of corresponding orders.
6. Conduct valuation of land related assets (Structures, trees, crops etc.) and liaison with respective State authority for authentication of the valuation.
7. Co-ordinate collection of documents including but not limited to sale deeds, circle rate and other information required by CALA to prepare 3G award
8. Assist CALA in 3G award preparation and in drafting 3G award documents
9. Deliver 3G award to PIU for approval along with valuation details
10. Assist CALA staff in preparation of field book which contains award by each beneficiary after 3G award is declared based on 3A, 3D and 3G notification

#### **5.1.9 Assist NHAI in obtaining possession of land**

1. Co-ordinate delivery of confirmation letter of deposit from PIU to CALA
2. Assist CALA staff in drafting notification for beneficiaries for award collection and vacating the land within 60 days (under section 3E)
3. Co-ordinate serving of notice to all beneficiaries for collection of award and to vacate the land within 60 days (under section 3E)
4. Co-ordinate collection of certificate of possession from CALA

#### **5.1.10 Publication of Gazette Notifications relating to Land Acquisition**

Cost for publication of Gazette Notifications relating to land acquisition in Newspapers shall be borne by the NHAI.

### **5.2 Utility shifting proposal and estimates**

#### **5.2.1 Identify type and location of all existing utilities within the proposed ROW**

1. Consultant will review information available with all utilities agencies in the region, consult maps/plans available with NHAI, MoRTH and state road agencies, consult with locals and municipal bodies to ascertain the presence and location of utilities, including but not limited to water-mains, gas, telephone, electricity and fiber-optic installations in and around the project road
2. Deploy ground penetrating radar, inductor locators or better technology to accurately map the location, type and size of utilities in the ROW of the project road as required in the section of this TOR
3. Develop a detailed strip plan and digitized maps showing:
  - i. type, size and current location of all the utilities identified
  - ii. relative offset from the centerline
  - iii. existing right of way

#### **5.2.2 Plan for utilities in future road design**

1. Consultants need to identify utilities that will require shifting to enable construction of the proposed project road
2. Incorporate space required for elevated and under-ground utilities corridors and utilities crossings as required for existing and future utilities in consultation with user departments

### **5.2.3 Develop a utilities relocation plan**

1. Consultants need to develop and submit a utilities relocation plan in consultation with NHAI and user departments clearly identifying current utilities and suggested relocations along with crossings as required
2. Plan and conduct discussions, consultations and joint site visits required for the planning of utilities shifting and the development of required drawings and proposals
3. Prepare necessary details, documents and suggested relocation plan to be submitted to user department
4. Develop initial cost estimates based on suggested relocation plan and the latest available schedule of rates for inclusion in the cost of the project at the time of approval

### **5.2.4 Estimates and approvals**

1. Consultants need to obtain draft utilities shifting proposal from user departments for all utilities identified for shifting along project road
2. Prepare utility shifting cost estimates using latest schedule of rates and obtain approval from user departments
3. Review final designs submitted, cost estimates, complete checklist, obtain required declarations and submit to PIU for approval
4. Work with user department, PIU and RO as required to incorporate any changes requested in shifting proposal and cost estimate by RO and NHAI HQ
5. Obtain all required utilities shifting proposal estimates and required approvals from both user departments and NHAI within the time stipulated in DPR contract

## **5.3 Estimation of Quantities and Project Costs**

1. The Consultants shall prepare detailed estimates for quantities (considering designs and mass haul diagram) and project cost for the entire project (civil packages wise), including the cost of environmental and social safeguards proposed based on MoRT&H's Standard Data Book and market rate for the inputs. The estimation of quantities shall be based on detailed design of various components of the projects. The estimation of quantities and costs would have to be worked out separately for civil work Package as defined in this TOR.
2. The Consultants shall make detailed analysis for computing the unit rates for the different items of works. The unit rate analysis shall duly take into account the various inputs and their basic rates, suggested location of plants and respective lead distances for mechanized construction. The unit rate for each item of works shall be worked out in terms of manpower, machinery and materials.
3. The project cost estimates so prepared for NHAI/ADB/WB projects are to be checked against rates for similar on-going works in India under NHAI/ World Bank/ ADB financed road sector projects.
4. The Consultant should work out the quantity of Bitumen, Steel and Cement likely to be used in the project and indicate in the summary sheet.

**6. Viability and Financing Options and Bidding process**

1. The Project Road should be divided into the traffic homogenous links based on the findings of the traffic studies. The homogenous links of the Project Road should be further subdivided into sections based on physical features of road and pavement, sub-grade and drainage characteristics etc. The economic and commercial analysis shall be carried out separately for each traffic homogenous link as well as for the Project Road.



2. The values of input parameters and the rationale for their selection for the economic and commercial analyses shall be clearly brought out and got approved by NHAI.

3. For models to be used for the economic and the commercial analyses, the calibration methodology and the basic parameters adapted to the local conditions shall be clearly brought out and got approved by NHAI.

4. The economic and commercial analyses should bring out the priority of the different homogeneous links in terms of project implementation.

### 6.1. Economic Analysis

1. The Consultants shall carry out economic analysis for the project. The analysis should be for each of the sections covered under this TOR. The benefit and cost streams should be worked out for the project using HDM-IV or other internationally recognized life-cycle costing model.

2. The economic analysis shall cover but be not limited to be following aspects:

i. assess the capacity of existing roads and the effects of capacity constraints on vehicle operating costs (VOC);

ii. calculate VOCs for the existing road situation and those for the project;

iii. quantify all economic benefits, including those from reduced congestion, travel distance, road maintenance cost savings and reduced incidence of road accidents; and,

iv. estimate the economic internal rate of return (EIRR) for the project over a 30-year period. In calculating the EIRRs, identify the tradable and non-tradable components of projects costs and the border price value of the tradable components.

v. Saving in time value.

3. Economic Internal Rate of Return (EIRR) and Net Present Value (NPV), “with “and “without time and accident savings” should be worked out based on these cost-benefit stream. Furthermore, sensitivity of EIRR and NPV worked out for different scenarios as given under:

Scenario - I	Base Costs and Base Benefits
Scenario - II	Base Costs plus 15% and Base Benefits
Scenario - III	Base Costs and Base Benefits minus 15%
Scenario - IV	Base Costs plus 15% and Base Benefits minus 15%

The sensitivity scenarios given above are only indicative. The Consultants shall select the sensitivity scenarios taking into account possible construction delays, construction costs overrun, traffic volume, revenue shortfalls, operating costs, exchange rate variations, convertibility of foreign exchange, interest rate volatility, non-compliance or default by contractors, political risks and force majeure.

4. The economic analysis shall take into account all on-going and future road and transport infrastructure projects and future development plans in the project area.

## **6.2 Financial Analysis**

### **6.2.1 Need for financial analysis**

1. It is envisaged that project stretches should be implemented in a commercial, PPP funded format
2. Therefore, the Consultant will need to study the financial viability of the project under various available commercial formats and suggest a mode of funding and execution that is most likely to be successful
3. The consultant shall study the financial viability of the project under several different traffic volume, user fee scenarios and funding options to arrive at the optimal execution mode and funding modalities

### **6.2.2 Financial analysis of the project**

1. The Consultants shall in consultation with NHAI finalize the format for the analysis and the primary parameters and scenarios that should be taken into account while carrying out the commercial analysis
2. The Financial analysis for the project should cover financial internal rate of return, projected income statements, balance sheets and fund flow statements and should bring out all relevant assumptions.
3. The financial analysis should cover identification, assessment, and mitigating measures for all risks associated with the project. The analysis shall cover, but be not limited to, risks related to construction delays, construction costs overrun, traffic volume, revenue shortfalls, operating costs, exchange rate variations, convertibility of foreign exchange, interest rate volatility, non-compliance or default by contractors, political risks and force majeure.
4. The sensitivity analysis should be carried out for a number of probabilistic scenarios.

### **6.2.3 Outputs from financial analysis**

1. The financial model so developed shall be handed over to and be the property of NHAI.
2. The consultant shall also suggest positive ways of enhancing the project viability and furnish different financial models for implementing on BOT format

## **6.3 Bidding process**

**6.3.1** Consultant shall assist the authority in preparing the required bid documents and support the authority through the bidding process

**6.3.2 Preparation of documents**

1. The consultant shall prepare all required bid documents and technical schedules required for the bidding of the project
2. The Consultants shall prepare separate documents for each type of contract (EPC/PPP) for each package of the DPR assignment
3. The consultant shall assist authority in reviewing bid documents and in making any changes required basis their findings or the and finalising bid documents
4. The consultant shall assist the authority in collecting and providing all required supporting documents for initiating bid as defined by the SOP for contracting
5. The DPR consultant may be required to prepare the Bid Documents, based on the feasibility report, due to exigency of the project for execution if desired by NHAI.
  - a. To enable this, consultant should study the financial viability and financial options for the project for modes such as BOT Toll/ Annuity during the feasibility stage.
6. Provide any and all clarifications required by the authority or other functionaries such as the financial consultant and legal advisor as required for the financial appraisal and legal scrutiny of the Project Highway and Bid Documents.
7. The consultant shall be guided in its assignment by the Model Concession/ Contract Agreements for PPP/ EPC projects, as applicable and the Manual of Specifications and Standards for two/ four/ six laning of highways published by IRC (IRC:SP:73 or IRC:SP:84 or IRC:SP:87, as applicable) along with relevant IRC codes for design of long bridges.
  - a. It is suggested that consultant should go through the EPC/ PPP documents of ministry before bidding the project.

**6.3.3 Support during the bidding process**

1. Consultant shall support NHAI through the entire bid process and shall be responsible for sharing the findings from the preparation stages during the bid process
2. The consultant shall ensure participation of senior team members of the consultant during all interaction with potential bidders including pre-bid conference, meetings, site visits etc.
3. During the bid process for a project, the consultant shall support the authority in:
  - a. Responding to all pre-bid technical queries
  - b. Preparation of detailed responses to the written queries raised by the bidders
4. The consultant shall assist NHAI and its functionaries as needed in the evaluation of technical bids

**7. Time period for the service**

1. Time period envisaged for the study of the project is indicated in **Annex-I to LOI**. The final reports, drawings and documentation shall be

completed within this time schedule.

2. NHA shall arrange to give approval on all sketches, drawings, reports and recommendations and other matters and proposals submitted for decision by the Consultant in such reasonable time so as not to delay or disrupt the performance of the Consultant's services.

## **8. Project Team and Project Office of the Consultant**

1. The Consultants shall be required to form a multi-disciplinary team for this assignment. The consultants' team shall be manned by adequate number of experts with relevant experience in the execution of similar detailed design assignments.
2. List of suggested key personnel to be fielded by the consultant with appropriate man-month of consultancy services is given in Enclosure-I as per client's assessment.
3. A Manning Schedule for key personnel mentioned above is enclosed as Enclosure-I along with broad job- description and qualification as Enclosure-II. The information furnished in Enclosures-I & II are to assist the Consultants to understand the client's perception about these requirements and shall be taken by the Consultants for the purpose of Financial Proposal and deployment schedule etc. in technical proposal to be submitted by them. Any deviation proposed may be recorded in the comments on TOR. All the key personnel mentioned will be evaluated at the time of evaluation of technical proposal. Consultants are advised in their own interest to frame the technical proposal in an objective manner as far as possible so that these could be properly assessed in respect of points to be given as part of evaluation criteria as mentioned in Data sheet. The bio-data of the key personnel should be signed on every sheet by the personnel concerned and the last sheet of each bio-data should also be signed by the authorized signatory of the Consultants.
4. The Consultants shall establish an office at the project site manned by senior personnel during the course of the surveys and investigations. All the project related office work shall be carried out by the consultant in their site office unless there are special reasons for carrying out part of the office work elsewhere for which prior approval of NHAI shall be obtained. The address of the site office including the personnel manning it including their Telephone and FAX numbers will be intimated by the Consultant to NHAI before commencement of the services.
5. The Consultant shall maintain an Attendance Register to be signed by each individual key personnel at site as well as at Head Office. The Consultant shall furnish certificate that all the key personnel as envisaged in the Contract Agreement have been actually deployed in the Projects at the time of submission of their bills to the NHAI from time to time.

## **9. Reports to be submitted by the Consultant to NHAI**

- 9.1 All reports, documents and drawings are to be submitted separately for each of the traffic homogenous link of the Project Road. The analysis of data and the design proposals shall be based on the data derived from the primary surveys and investigations carried out during the period of assignment. The sources of data and model relationships used in the reports shall be indicated with complete details for easy reference.

9.2 Project preparation activities will be split into eight stages as brought out below.

No	Stage	Key activities	Report/deliverable submitted
1	Inception	Project planning and mobilization	Inception Report and QAP
2	Feasibility	Alignment finalization, preliminary surveys	Alignment Options Report and Feasibility Report
3	LA and Clearances I	LA, utilities identification; creation of draft notifications and proposals	Strip Plan, LA Report (3a, 3A), Clearances and Utility Shifting proposals
4	DPR	Detailed design of highway, preparation of detailed project report with drawings	Draft DPR Report, Final DPR Report, documents and drawings
5	Technical Schedules	Preparation of bid documents and technical schedules	Civil Works Contract Agreement and Schedules
6	(i) LA II (ii) Project Clearances	<i>Land acquisition process, obtaining final utilities estimates and required clearances</i>	<i>JMS and 3D Report, Final Project Clearances and Utilities Report</i>
7	LA III- Award Determination	Land acquisition award determination	<i>3G Report</i>
8	LA IV- Possession	<i>Obtaining possession of land</i>	<i>Land Possession Report</i>

Preliminary design work should commence without waiting for feasibility study to be completed. Stage 3, 5 and 6 shall run in parallel with Stage 2 and 4

For stages 7 and 8 consultant will be required to submit a report at the completion of 90% of the activities for that stage. In addition, an updated report will need to be submitted at the completion of all land acquisition activities covering receipt of 100% of the land possession certificates for the land parcels pertaining to the project road.

### 9.3 Timelines for the submission of reports and documents

Consultant shall be required to complete, to the satisfaction of the client, all the different stages of study within the time frame indicated in the schedule of submission in para 10 pertaining to Reports and Documents for becoming eligible for payment for any part of the next stage.

## 10 Reports and Documents to be submitted by the Consultant to NHAI

1. The Consultant shall submit to the client the reports and documents in bound volumes (and not spiral binding form) after completion of each stage of work as per the schedule and in the number of copies as given in Enclosure-III. Further, the reports shall also be submitted in floppy diskettes / CD's in addition to the hardcopies as mentioned in Enclosure-III. Consultant shall submit all other reports mentioned specifically in the preceding paras of the TOR.
2. The time schedule for various submissions prescribed at Sl. No.1 above shall be strictly adhered to. No time overrun in respect of these

submissions will normally be permitted. Consultant is advised to go through the entire terms of reference carefully and plan his work method in such a manner that various activities followed by respective submissions as brought out at Sl.No.1 above are completed as stipulated. Consultant is, therefore, advised to deploy sufficient number of supporting personnel, both technical and administrative, to undertake the project preparation activities in construction package (Section) simultaneously. As far as possible, the proposal should include complete information such as number of such persons, name, position, period of engagement, remuneration rate etc. The Consultant is also advised to start necessary survey works from the beginning so as to gain time in respect of various other activities in that stage.

### **3. DPR Deliverables in each stage of project**

1. The key stages, activities and deliverables for the detailed project report are as described in these documents
2. The following section describes the detailed requirements for each report that needs to be submitted
3. Consultants are also advised to refer to Enclosure IV: Formats for submission of Reports and Documents to understand any additional format and content requirements
4. All reports must be submitted along with the relevant checklist form completed and signed off by the consultant

## **STAGE 1**

### **10.1 Quality Assurance Plan (QAP) Document**

1. Immediately upon the award, the Consultants shall submit four copies of the QAP document covering all aspects of field studies, investigations design and economic financial analysis. The quality assurance plans/procedures for different field studies, engineering surveys and investigation, design and documentation activities should be presented as separate sections like engineering surveys and investigations, traffic surveys, material geo-technical and sub-soil investigations, road and pavement investigations, investigation and design of bridges & structures, environment and R&R assessment, economic & financial analysis, drawings and documentation; preparation, checking, approval and filing of calculations, identification and traceability of project documents etc. Further, additional information as per format shall be furnished regarding the details of personnel who shall be responsible for carrying out/preparing and checking/verifying various activities forming part of feasibility study and project preparation, since inception to the completion of work. The field and design activities shall start after the QAP is approved by NHAI.
2. Data formats for report and investigation result submission
  - i. Required data formats for some reports, investigations and documents are discussed in Enclosure IV: Formats for submission of Reports and Documents.

- ii. The consultants will need to propose data formats for use in all other field studies and investigations not covered in enclosure IV.
- iii. The proposed data forms will need to be submitted for the approval of NHAI after the commencement of services.

## 10.2 Inception Report (IR)

1. The report shall cover the following major aspects:
  - i. Project appreciation;
  - ii. Detailed methodology to meet the requirements of the TOR finalized in consultation with the NHAI officers; including scheduling of various sub activities to be carried out for completion of various stages of the work; stating out clearly their approach & methodology for project preparation after due inspection of the entire project stretch and collection/ collation of necessary information;
  - iii. Task Assignment and Manning Schedule;
  - iv. Work programme;
  - v. Proforma for data collection;
  - vi. Design standards and proposed cross-sections;
  - vii. Key plan and Linear Plan;
  - viii. Development plans being implemented and / or proposed for implementation in the near future by the local bodies and the possible impact of such development plans on the overall scheme for field work and design for the study;
  - ix. Quality Assurance Plan (QAP) finalized in consultation with NHAI;
  - x. Draft design standards; and
  
2. The requirements, if any, for the construction of bypasses should be identified on the basis of data derived from reconnaissance and traffic studies. The available alignment options should be worked out on the basis of available maps. The most appropriate alignment option for bypasses should be identified on the basis of site conditions and techno-economic considerations. Inception Report should include the details regarding these aspects concerning the construction of bypasses for approval by NHAI.
  - i. Bypasses should be identified on the basis of data derived from reconnaissance and initial traffic information/traffic studies
  - ii. The available alignment options should be worked out on the basis of available topographic maps, publicly available mapping services or remote sensing based topography and land use maps
  - iii. The most appropriate alignment option for bypasses should be identified on the basis of site conditions and techno-economic considerations



## STAGE 2: Feasibility Report

### 10.3 Alignment options report

1. Basis review of the existing project road, local traffic patterns and initial reconnaissance surveys, the consultant shall present possible alignment alternatives for the project road
2. Alignment options should include but not be limited to:
  - (i) Greenfield sections of the road
  - (ii) New alignments due to lack of RoW, opportunity to shorten road etc.
  - (iii) New/Re-alignment to cater to local traffic and o-d points
  - (iv) Re-alignment due to changes in local network and/or surrounding road network
  - (v) Bypasses as suggested and approved in alignment report
  - (vi) Re-alignment due to need to improve road geometry
  - (vii) Provision of ROBs, flyovers and other structures
3. The alignment report shall contain:
  - i. Drivers for re-alignment of road and re-alignment needed as discussed in para 2 above
  - ii. Alignment alternatives for each section where re-alignment of road is needed
  - iii. Analysis of alignment alternatives bringing out the pros and cons of each alternative including, but not limited to: new construction required, land acquisition requirements, environmental impact, utilities and structures affected, cost of construction, road geometry and road safety aspects, input from local consultation, NHAI views
  - iv. Recommendations from among the alignment options presented for the authority to consider
    - a. Consultant will enable authority to visualize and compare alignment options by providing alignment options in a GIS environment that should include, but not be limited to:
      - i. Road alignment alternative centerlines
      - ii. Digital elevation model of the region
      - iii. Land use / land cover information
      - iv. Hydrology information
      - v. Surrounding road network including key NH, SH, MDR and ODRs
      - vi. Key O/D points and urban settlements
      - vii. High resolution satellite/airborne imagery of the region

### 10.4 Feasibility Report

1. The consultant shall commence the Feasibility Study of the project in accordance with the accepted IR and the report shall contain the following:
  - i. Executive summary
  - ii. Overview of NHAI organization and activities, and project financing and cost recovery mechanisms
  - iii. Project description including possible alternative alignments/bypasses and technical/engineering alternatives
  - iv. Methodology adopted for the feasibility study

- v. Socioeconomic profile of the project areas
  - vi. Indicative design standards, methodologies and specifications
  - vii. Traffic surveys and analysis
  - viii. Environmental screening and preliminary environmental assessment
  - ix. Initial social assessment and preliminary land acquisition/resettlement plan
  - x. Cost estimates based on preliminary rate analysis and bill of quantities,
  - xi. Cost analysis of all alternate identified alignments
  - xii. Economic and financial analysis
  - xiii. Conclusions and recommendations
2. In view of para 1 above the consultant has to submit the following documents in six sets:
- i. **Technical Specifications:** The MORT&H's Technical Specifications for Road and Bridge works shall be followed for this study. However, Volume-IV: Technical Specifications shall contain the special technical specifications which are not covered by MORT&H Specifications for Roads and Bridges (latest edition / revision) and also specific quality control norms for the construction of works.
  - ii. **Rate Analysis:** This volume will present the analysis of rates for all items of works. The details of unit rate of materials at source, carriage charges, any other applicable charges, labour rates, and machine charges as considered in arriving at unit rates will be included in this volume.
  - iii. **Cost Estimates:** This volume will present the each item of work as well as a summary of total cost.
  - iv. **Bill of Quantities:** This volume shall contain the detailed Bill of Quantities for all items of works
3. The basic data obtained from the field studies and investigations shall be submitted in a separate volume as an Appendix to Feasibility Report.
4. The Final Feasibility Study Report incorporating comments, revisions and modifications suggested by NHAI shall be submitted within 15 days of receipt of comments from NHAI on draft feasibility study report.

### **STAGE 3:**

#### **10.5 Strip Plan and Clearances**

- 1. The Consultants shall submit the following documents:
  - i. Details of the center line of the proposed widened NH along with the existing and proposed right-of-way limits to appreciate the requirements of land acquisition;
  - ii. The information concerning the area including ownership of land to be acquired for the implementation of the project shall be collected from the revenue and other concerned authorities and presented along with the strip plans;

- iii. Strip plans showing the position of existing utilities and services indicating clearly the position of their relocation;
  - iv. Details for various clearances such as environment and forest clearances;
  - v. Separate strip plan showing shifting / relocation of each utility services in consultation with the concerned local authorities;
  - vi. The utility relocation plans should clearly show existing right-of-way and pertinent topographic details including buildings, major trees, fences and other installations such as water-mains, telephone, telegraph and electricity poles, and suggest relocation of the services along with their crossings the highway at designated locations as required and prepare necessary details for submission to the Service Departments;
  - vii. Detail schedules for acquisition of additional land and additional properties in consultation with the revenue authorities; and
  - viii. Land Acquisition Plan shall be prepared after digitization of cadastral / land revenue maps. The digitized map shall exactly match the original map, like a contact print, since the dimensions and area of plots, or the whole village is to be extracted from the map itself. An accuracy of 1mm or higher in a 1:1000 scale map shall be ensured, as this translates into an accuracy of 1 m or higher on ground.
2. The strip plans and land acquisition plan shall be prepared on the basis of data from reconnaissance and detailed topographic surveys.
  3. The Report accompanying the strip plans should cover the essential aspects as given under:
    - i. Kilometre-wise Land Acquisition Plan (LAP) and schedule of ownership thereof and Costs as per Revenue Authorities and also based on realistic rates.
    - ii. Details of properties, such as buildings and structures falling within the right-of way and costs of acquisition based on realistic rates.
    - iii. Kilometre-wise Utility Relocation Plan (URP) and costs for relocation per civil construction package as per concerned authorities.
    - iv. Kilometre-wise account in regard to felling of trees of different type and girth and value estimate of such trees based on realistic rates obtainable from concerned District forest office.
  4. The strip plans shall clearly indicate the scheme for widening. The views and suggestions of the concerned State PWDs should be duly taken into account while working out the widening scheme (left, right or symmetrical). The widening scheme shall be finalized in consultation with NHAI.
  5. Kilometre-wise Strip Plans for section (Package) shall be prepared separately for each concerned agency and suggested by NHAI.

## 10.6 Land Acquisition Report

1. Consultant shall submit a detailed land acquisition plan that provides details on kilometre-wise land acquisition requirements, all required details and draft notifications made.
2. The Land acquisition plan and report shall be prepared and submitted for each section (package). Details shall also be submitted in land acquisition proforma to be supplied by NHAI, in both Hind and English languages.
3. The Land Acquisition Plan shall be prepared after digitization of cadastral/land revenue maps as per clause 5.1.2 Digitization of cadastral maps of this TOR
  - i. Land parcels identification should be verified by superimposing the proposed road corridor RoW on the geo-located cadastral map to ensure all affected land parcels have been accounted for and land area to be acquired is accurately determined
4. The land acquisition plan shall present details concerning the land area to be acquired in conjunction with the strip plan:
  - i. Kilometer-wise existing and proposed RoW on either side of the proposed centreline
  - ii. Detail schedules of additional land to be acquired, land ownership and other required details as per revenue records
  - iii. Details of properties, such as buildings and structures falling within the right-of way
  - iv. Costs of acquisition as per revenue authorities and also based on realistic market derived rates
  - v. Detail schedules for acquisition of additional land and additional properties in consultation with the revenue authorities;
5. The land acquisition plan shall report the progress of the land acquisition process under the NH Land Acquisition act
  - i. All required details on land parcels to be acquired
  - ii. Copies draft 3a and 3A notifications and approvals from NHAI
  - iii. Copies of published notifications, communication with CALAs and current status land acquisition process
  - iv. Village, district and CALA wise summary of land to be acquired, current status of process and notifications published
6. The land acquisition report should be prepared in consultation with affected persons, non-governmental organisations and concerned government agencies and should cover land acquisition and resettlement plan and estimated costs of resettlement and rehabilitation of affected persons.

#### **10.7 Utility relocation plan**

1. The consultant shall prepare a kilometre-wise Utility Relocation Plan (URP) and costs for relocation per civil construction package as per estimates from concerned authorities
2. The utility relocation shall contain details regarding:
  - i. All utilities identified in the existing and proposed road RoW such as water-mains, telephone, telegraph and electricity poles
  - ii. Those utilities that will require shifting to enable construction of the project road

- iii. All necessary details required for submission of utilities shifting proposals to the concerned user agencies
- iv. Copies of utilities shifting proposals made to the concerned user agencies along with suggested relocation of services along with their crossings across the project road at designated locations as required
- v. Details of consultations made with local people and user agencies
- vi. Preliminary scheme for shifting and cost estimates for shifting as per the concerned authorities
- vii. Separate strip plan showing shifting/relocation of each utility services prepared in consultation with the concerned local authorities
- viii. Draft map and plans showing road centerline, existing right of way, proposed right of way, pertinent topographic details and existing and proposed location of utilities

### **10.8 Clearances report**

- 1. The consultant shall prepare a report regarding all other clearances required to enable the construction of the project road such as environment, forest, tree cutting and railways clearances
- 2. The clearances report shall include kilometre-wise requirement of all clearances required presented along with the strip plan including, but not limited to:
  - i. Requirements for environmental clearances along the project corridor
  - ii. Requirements for forest clearances including type of forest affected, extent of land area needing diversion
  - iii. Account of required felling of trees of different type and girth and value estimate of such trees based on realistic rates obtainable from concerned District forest office
  - iv. Plan of compensating afforestation, its land requirement with specific locations and cost involved for undertaking all activities in this regard.
  - v. ROB/RUBs along the project corridor to be constructed, widened or modified in any form requiring clearances from the railways
- 3. The clearances report shall also include:
  - i. Details of proposals made to concerned agencies and departments
  - ii. Date of submission of clearances proposals, Environmental impact assessment report to the competent authority
  - iii. Copies of all actual clearance proposals made or drafts of proposals yet to be submitted
  - iv. Information regarding points of contact, current status of proposals made, key issues raised and clear next steps to obtaining clearances

## **STAGE: 4**

### **10.9 Draft Detailed Project Report (DPR)**

- 1. The draft DPR Submission shall consist of construction package-wise Main Report, Design Report, Materials Report, Engineering Report,

Drainage Design Report, Economic and Financial Analysis Report, Environmental Assessment Report including Resettlement Action Plan (RAP), Package-wise bid Documents and Drawings.

2. The Report volumes shall be submitted as tabulated in para 10 above.
3. The Documents and Drawings shall be submitted for the Package and shall be in the following format:

### Reports

- i. **Volume-I, Main Report:** This report will present the project background, social analysis of the project, details of surveys and investigations carried out, analysis and interpretation of survey and investigation data, traffic studies and demand forecasts designs, cost estimation, environmental aspects, economic and commercial analyses and conclusions. The report shall include Executive Summary giving brief accounts of the findings of the study and recommendations. A sample executive summary has been enclosed in Appendix VIII.

The Report shall also include maps, charts and diagrams showing locations and details of existing features and the essential features of improvement and upgrading. The Environmental Impact Assessment (EIA) Report for contract package shall be submitted as a part of the main report.

The basic data obtained from the field studies and investigations and input data used for the preliminary design shall be submitted in a separate volume as an Appendix to Main Report.

- ii. **Volume - II, Design Report:** This volume shall contain design calculations, supported by computer printout of calculations wherever applicable. The Report shall clearly bring out the various features of design standards adopted for the study. The design report will be in two parts. Part-I shall primarily deal with the design of road features and pavement composition while Part-II shall deal with the design of bridges, tunnels and cross-drainage structures. The sub-soil exploration report including the complete details of boring done, analyses and interpretation of data and the selection of design parameters shall be included as an Appendix to the Design Report.

The detailed design for all features should be carried out as per the requirements of the Design Standards for the project. However, there may be situations wherein it has not been possible to strictly adhere to the design standards due to the existing site conditions, restrictions and other considerations. The report should clearly bring out the details of these aspect and the standards adopted.

- iii. **Volume - III, Materials Report:** The Materials Report shall contain details concerning the proposed borrow areas and quarries for construction materials and possible sources of water for construction purposes. The report shall include details on locations of borrow areas and quarries

shown on maps and charts and also the estimated quantities with mass haul diagram including possible end use with leads involved, the details of sampling and testing carried out and results in the form of important index values with possible end use thereof.

The materials Report shall also include details of sampling, testing and test results obtained in respect physical properties of subgrade soils. The information shall be presented in tabular as well as in graphical representations and schematic diagrams. The Report shall present soil profiles along the alignment.

The material Report should also clearly indicate the locations of areas with problematic soils. Recommendations concerning the improvement of such soils for use in the proposed construction works, such as stabilization (cement, lime, mechanical) should be included in the Report.

- iv. **Volume - IV, Environmental Assessment Report including Environmental Management Plan (EMP) & Resettlement Action Plan (RAP):** The Report shall be prepared conforming to the Guidelines of the Government of India, State Government and World Bank / ADB as appropriate for construction package.
- v. **Volume-V, Technical Specifications:** The MORT&H's Technical Specifications for Road and Bridge works shall be followed for this study. However, Volume IV: Technical Specifications shall contain the special technical specifications which are not covered by MOST Specifications for Roads and Bridges (latest edition / revision) and also specific quality control norms for the construction of works.
- vi. **Volume - VI, Rate Analysis:** This volume will present the analysis of rates for all items of works. The details of unit rate of materials at source, carriage charges, any other applicable charges, labour rates, machine charges as considered in arriving at unit rates will be included in this volume.
- vii. **Volume - VII, Cost Estimates:** This volume will present the contract package wise cost of each item of work as well as a summary of total cost.
- viii. **Volume - VIII, Bill of Quantities:** This volume shall contain the package-wise detailed Bill of Quantities for all items of works.
- ix. **Volume - IX, Drawing Volume:** All drawings forming part of this volume shall be 'good for construction' drawings. All plan and profile drawings will be prepared in scale 1:250V and 1:2500H scale to cover one km in one sheet. In addition this volume will contain 'good for construction' drawings for the following:
  - Horizontal Alignment and Longitudinal Profile.
  - Cross-section @ 50m interval along the alignment within ROW
  - Typical Cross-Sections with details of pavement structure.
  - Detailed Working Drawings for individual Culverts and Cross Drainage

- Structures.
  - Detailed Working Drawings for individual Bridges, tunnels and Structures.
  - Detailed Drawings for Improvement of At-Grade and Grade-Separated
  - Intersections and Interchanges.
  - Drawings for Road Sign, Markings, Toll Plazas, and other Facilities.
  - Schematic Diagrams (linear chart) indicating but be not limited to be following:
    - Widening scheme;
    - Locations of median openings, intersections, interchanges, underpasses, overpasses, bypasses;
    - Locations of service roads;
    - Location of traffic signals, traffic signs, road markings, safety features; and,
    - Locations of toll plaza, parking areas, weighing stations, bus bays, rest areas, if any.
  - Drawings for toll plaza, Bus Bays, Parking areas, Rest areas, weighing stations etc. All drawings will be prepared in A2 size sheets. The format for plan, cross section and profile drawings shall be finalized in consultation with the concerned NHAI officers. The drawings shall also include details of all BM and reference pillars, HIP and VIP. The co-ordinates of all points should be referenced to a common datum, preferably GTS referencing system. The drawings shall also include the locations of all traffic safety features including traffic signals, signs, markings, crash barriers, delineators and rest areas, busbays, parking areas etc.
  - The typical cross-section drawings should indicate the scheme for future widening of the carriageway. The proposed cross-sections of road segment passing through urban areas should indicate the provisions for pedestrian movements and suitable measures for surface and sub-surface drainage and lighting, as required.
  - Digital drawings of proposed highway and features
    - a. The consultant shall deliver the final road alignment geometry, proposed road way model and all proposed structures in a 3D engineered model with all the required features as proposed in Enclosure IV
    - b. The consultant shall also provide digital versions of all drawings stated in para 1 above in the format proposed in Enclosure IV
4. The draft Detailed Project report of specialized projects will be scrutinized by the Peer Review consultant appointed by NHAI. The peer Review Consultant will be retired professional in the field, drawn from the various Central/State Highway/Road Work departments having adequate knowledge in the field. One professional will be earmarked from the standing panel of Peer Review consultant approved by NHAI for each DPR. The Peer Review consultant will scrutinize the draft DPR within 15 days of submission and the observations will be complied with and incorporated in the final DPR.

#### 10.10 Final Detailed Project Report, Documents and Drawings (6 Sets)



1. The Final package-wise DPR consisting of Main Report, Design Report, Drainage Design Report and Materials Report, incorporating all revisions deemed relevant following receipt of the comments from NHAI on the draft DPR shall be submitted as per the schedule given in Enclosure-III.

## **STAGE: 5**

### **10.11 Bid documents and Technical Schedules**

- 1. Bid documents**
  - a. The consultant shall prepare bid documents for EPC, PPP or other modes of contracting as suggested by NHAI
  - b. Individual bid documents will be submitted for each mode suggested and for each individual package or section identified for execution
  - c. Consultant shall assemble and provide all supporting documents from the DPR assignment that will be required for the bid, in the format required by the contracting SOP in force at the time of bidding or as maybe required by the authority
- 2. Technical Schedules**
  - a. The consultant shall submit a Draft Contract/Concession Agreement derived from the Master Contract/Concession Agreement maintained by the authority with all required modifications and inclusions made with reference to the
  - b. The agreement submitted shall contain all required technical schedules updated with the pertinent project details and data required
  - c. Draft agreement and schedules shall be finalised in consultation with the authority and submitted for further processing and use with the contractor/concessionaire awarded the bid packages

## **STAGE: 6**

### **10.12 LA & Clearances II Report**

#### **Land acquisition report II**

1. The consultant shall prepare and submit a second report on Land Acquisition providing details of further land acquisition activity, relevant documentation and notifications until 3D and report the outcomes of the joint measurement survey
2. The land acquisition report shall contain:
  - i. Current status of land acquisition at a village, district and CALA level
  - ii. Dates and details of all land acquisition related notifications published, proceedings/hearings held and objections raised
  - iii. Draft, final (as declared by CALA where applicable) and published 3a, 3A and 3D notifications
  - iv. Date of joint measurement survey by village, key proceedings and outcomes
  - v. Detailed schedule of information regarding land to be acquired with information on land area, land type, nature of land use, ownership status, and area to be acquired by survey number and list of structures by plot
  - vi. The report shall also contain updated sketches of alignment, updated land parcels to be acquired

- vii. All relevant information in this report shall be verified by the consultant with the land revenue department, and CALA office

### **Clearances Report II**

1. The consultant shall obtain all the necessary project related clearances such as environment, forest and wildlife clearance from MOEF, Railways in respect of ROB/ RUBs, Irrigation Deptt and any other concerned agencies by the end of this stage
2. The final approvals shall be obtained and submitted to NHAI so that project implementation can begin straight away
3. The accompanying report on clearances shall include:
  - i. An updated list of all clearances required, current status, expected completion date in case the clearance is pending, key issues and suggested next steps
  - ii. Details of all public hearings, consultations and meetings conducted in the process of obtaining the required clearances
  - iii. Date/details of proposals submitted and estimated date for issue of clearances
  - iv. Date and details of all joint measurement and site inspection surveys completed
  - v. Date of final approval of clearances if any
  - vi. Copies of all clearances obtained

### **Utilities Report II**

1. Consultant shall obtain final utility clearances from the relevant user agencies to enable shifting of the utilities from project road
2. A report shall be submitted on the final completion status and costs of utilities shifting along with other final clearances and land acquisition II report
3. The final utilities clearances report shall contain a summary view of utilities shifting: type and extent of utility, length of road affected, chainage, user agency, point of contact and approver at agency, date of approval at agency and NHAI, shifting estimate, agency/super vision fees, executing agency - user agency or NHAI
4. In addition, for each utility to be shifted, the report shall contain:
  - i. Copies of actual approvals granted at user agency and NHAI
  - ii. Cost estimates and shifting plans approved, demand note from agency
  - iii. Approved utilities shifting proposal including strip plan showing scheme of shifting
  - iv. Map and design/engineering drawings of existing utility and shifting to be executed
  - v. Details of approved contractors, schedule of rates for state and bank account/deposit details for agency
  - vi. Finance pro-forma, utilities checklist, no upgradation certificate and other documentation as maybe required by NHAI at the time of approval

## Stage 7: Award Determination

- 10.13 Submission of Award Determination Report
- a. Consultant shall submit a report on status of award upon approval by NHAI of award declared for 90% of area as per LA plan or as per the timeline as given in Enclosure III, whichever is earlier
  - b. The Consultant shall also submit an updated report containing all required details upon approval of award by NHAI of 100% of land required to be acquired
  - c. The Land award report shall contain details of:
    - i. Summary of compensation award status by village including:
      1. total private and public land being acquired for the project (sq. m) - by village
      2. date of 3A& 3D, final award by CALA, approval by NHAI by village
      3. variation of land area and nature of land use against that notified in 3D with reasons
      4. Total award declared by village, claims made by beneficiaries and status of disbursement
    - ii. In detail for each village:
      1. Updated land acquisition tracker containing parcel-wise status of each notification, award and disbursement
      2. Method used by CALA for arrival on market value
      3. Valuation report and details of Award calculation
      4. Claims report (received under sub-section 3 of 3G)
      5. Copies of notifications published, certificates received
      6. Deviations in area according to CALA from provisions under sec. 26-30
    - iii. Key issues being faced in completing land acquisition and tentative timeline for completion
    - iv. A GIS map containing digitised details of land parcels shall be updated with all relevant land possession details and supplied in the agreed digital format

## Stage 8: Land Possession

- 10.14 Submission of land possession report
- a) The consultant shall submit a report on status of land possession upon receiving land possession certificates for 90% of area as per LA plan or as per the timeline as given in Enclosure III, whichever is earlier
  - b) The Consultant shall also submit an updated report containing all required details upon completion of 100% of land possession certificates
  - c) The land possession report shall contain
    - i. Summary of land possession status by village including:
      - total private and public land being acquired for the project (sq. m) - by village
      - date of final award by CALA, approval by NHAI, notification (3E) to owners and receipt of land possession certificates from CALA by village
      - Status of disbursement on the date of receipt of land possession certificate
    - ii. Key issues being faced in completing land acquisition and tentative timeline for completion
    - iii. Land possession certificates as received from CALA by village

- iv. Updated land acquisition tracker containing parcel-wise status of each notification and disbursement status
- v. A GIS map containing digitised details of land parcels shall be updated with all relevant land possession details and supplied in the agreed digital format

## **11. Interaction with NHAI**

- 1. During entire period of services, the Consultant shall interact continuously with NHAI and provide any clarification as regards methods being followed and carryout modification as suggested by NHAI. A programme of various activities shall be provided to NHAI and prior intimation shall be given to NHAI regarding start of key activities such as boring, survey etc. so that inspections of NHAI officials could be arranged in time.
- 2. The NHAI officers and other Government officers may visit the site at any time, individually or collectively to acquaint/ supervise the field investigation and survey works. NHAI may also appoint a Proof Consultant to supervise the work of the DPR consultant including inter-alia field investigation, survey work, Design work and preconstruction activities
- 3. The consultant shall be required to send 3 copies of concise monthly Progress Report by the 5th day of the following month to the designated officer at his Head Quarter so that progress could be monitored by the NHAI. These reports will indicate the dates of induction and de-induction of various key personnel and the activities performed by them. Frequent meetings with the consultant at site office or in Delhi are foreseen during the currency of project preparation.
- 4. All equipment, software and books etc. required for satisfactory services for this project shall be obtained by the Consultant at their own cost and shall be their property.

## **12. Payment Schedule**

- 1. The Consultant will be paid consultancy fee as a percentage of the contract values as per the schedule given in the Draft Contract Agreement.

## **13. Data and Software**

- a. Consultants shall also deliver to NHAI all basic as well as the processed data from all field studies and investigations, report, appendices, annexure, documents and drawings in a digital format as described in Enclosure IV over the course of this assignment and at the submission of the final report in the form of a removable storage device (CD or USB pen drive) and hosted in a secure online file hosting platform
- b. If required by NHAI the consultant shall arrange at their own cost necessary software for viewing and measurement of imagery/ point cloud data.

- i. **Engineering Investigations and Traffic Studies:** Road Inventory, Condition, Roughness, Test Pit (Pavement composition), Falling Weight Deflectometer (FWD) Material Investigation including test results for subgrade soils, Traffic Studies(traffic surveys), axle load surveys, Sub-soil Exploration, Drainage Inventory, Inventory data for bridge and culverts indicating rehabilitation, new construction requirement etc. in MS EXCEL or any other format which could be imported to widely used utility packages.
  - ii. **Topographic Surveys and Drawings:** All topographic data would be supplied in (x, y, z) format along with complete reference so that the data could be imported into any standard highway design software. The drawing files would be submitted in dxf or dwg format.
  - iii. **Rate Analysis:** The Consultant shall submit the rate analysis for various works items including the data developed on computer in this relation so that it could be used by the Authority later for the purpose of updating the cost of the project.
  - iv. **Economic and Financial Analysis**
2. **Software:** The Consultant shall also hand-over to NHAI floppies/CD's containing any general software including the financial model which has been specifically developed for the project.
  3. The floppy diskettes/CD's should be properly indexed and a catalogue giving contents of all floppies/CD's and print-outs of the contents (data from field studies topographic data and drawings) should be handed over to NHAI at the time of submission of the Final Report.
  4. Consultant shall include editable soft copies of the final versions of all documents, including but not limited to the strip plan, plan & profile drawings, cross sections of right of way and details of structures as well as any cost workings.

## SUPPLEMENT I

### ADDITIONAL POINTS TO BE CONSIDERED FOR HILL ROADS IN ADDITION TO POINTS COVERED IN MAIN TOR

Sr. No.	Clause No. of TOR	Additional points
1.	2.2	a) Provisions of tunnels if required.
2.	2.3	a) Design of tunnels, if required b) Design of protective works, slope stabilization measures, erosion control measures, land slide control/protection measures snow drift control/snow clearance measures, avalanche protection measures, if required
3.	3	Feasibility study and preparation of detailed project report for hill roads shall be done in accordance with best international practices and wherever practicable/feasible steep gradients and hair pin bends may be avoided by realignments by provision of structures and provision of tunnels if required
4.	4.1	a) Inventory and condition survey for tunnels, if required. b) Identification of faults in rock strata and impact of faults in design of tunnels, if required c) Detailed design of road considering and incorporating specific aspects related to hill region like terrain, topographic conditions, extreme weather conditions, altitude effects etc. d) Design of protective works, slope stabilization measures, erosion control measures, land slide control/protection measures, snow drift control/snow clearance measures, avalanche protection measures, if required e) Design of scenic overlooks/watering points etc.
5.	4.5 (1)	All activities related to field studies, design and documentation shall be done as per the latest guidelines/circulars of MORT&H and relevant publications of the Indian Roads Congress (IRC)/Bureau of Indian Standards (BIS) for hill roads. For aspects not covered by IRC and BIS, international standard practices, such as, British and American Standards may be adopted.

6.	4.7	<p>Review of data and documents pertaining to</p> <ul style="list-style-type: none"> <li>a) Terrain and soil condition</li> <li>b) Condition of tunnels, if required.</li> <li>c) Sub-surface and geo-technical data for existing tunnels, if required.</li> <li>d) Drawing and details of existing tunnels, if required.</li> <li>e) Existing protective works, erosion control and land slide control/protection works, slope stabilization measures, snow drift control measures, avalanche protection measures</li> <li>f) Existing land slide and snow clearance facilities</li> <li>g) Geological details of rock strata in the area in case of tunnels</li> </ul>
7.	4.11.1(1)	The Consultant should make an in depth study of available geological and Meteorological maps of the area.
8.	4.11.1(2)	<p>The primary tasks to be accomplished during the reconnaissance survey shall also include:</p> <ul style="list-style-type: none"> <li>a) details of terrain (steep or mountainous), cliffs and gorges, general elevation of the road including maximum heights negotiated by main ascents and descents, total number of ascents and descents, hair pin bends, vegetation etc.</li> <li>b) Climatic conditions i.e. temperature, rainfall data, snowfall data, fog conditions, unusual weather conditions etc.</li> <li>c) Realignment requirements including provision of tunnels, if required.</li> <li>d) Inventory of tunnels and geologically sensitive areas like slip prone areas, areas subject to landslides, rockfall, snow drifts, erosion, avalanche activity etc.</li> </ul>
9.	4.11.2.1 (3.ii)	Cross sections shall be taken at every 25 m. in case of hill roads and at points of appreciable changes in soil conditions. While taking cross sections, soil conditions shall also be recorded.
10.	4.11.3.1 (1)	<p>The inventory data shall also include:</p> <ul style="list-style-type: none"> <li>a) General elevation of road indicating maximum &amp; minimum heights negotiated by main ascents &amp; descents and total no. of ascents &amp; descents.</li> <li>b) Details of road gradients, lengths of gentle &amp; steep slopes, lengths &amp; location of stretches in unstable areas, areas with cliffs, areas with loose rocks, land slide prone areas, snow drift prone areas, no. &amp; location of hairpin bends etc.</li> <li>c) Details of tunnels</li> <li>d) Details &amp; types of protective structures, erosion &amp; land slide control/protection measures, snow drift control measures, avalanche protection/control measures etc.</li> </ul>
11.	4.11.3.2 (2)	<p>Pavement:</p> <ul style="list-style-type: none"> <li>a) Location of crust failures along with their causes</li> <li>b) Conditions of camber/cross falls/super elevations etc., whether affected by subsidence Embankment: Extent of slope erosion on hill and valley side</li> </ul>



12.	--	<p>Condition Surveys &amp; Investigation for Slope Stabilization, Erosion Control, Landslide Correction/Protection &amp; Avalanche Protection Measures:</p> <p>a) Inventory &amp; Condition Surveys of Existing Protective/Control Measures: The consultant shall make an inventory of all the structures related to Slope Stabilization, Erosion Control, Landslide Control/protection, Avalanche Protection etc. This shall include details of effectiveness of control measures already done and condition of protective/control structures.</p> <p>b) Landslide Investigation This shall be carried out to identify landslide prone areas, to suggest preventive measures or alternate routes that are less susceptible to landslide hazard. Further in existing slide areas this shall help to identify factors responsible for instability and to determine appropriate control measures needed to prevent or minimize recurring of instability problems. Initial preliminary studies shall be carried out using available contour maps, topographical maps, geological/geo-morphological maps, aerial photographs etc. for general understanding of existing slide area and to identify potential slide areas. This shall be followed by further investigations like geological/geotechnical/hydrological investigation to determine specific site conditions prevailing in the slide area as per relevant IRC specifications/publications, MORT&amp;H circulars and relevant recommendations of the international standards for hill roads. The result of the investigations shall provide basis for engineering analysis and the design of protection/remedial measures.</p>
13.	4.11.4.4	<p>a) For tunnels if required, geotechnical and subsurface investigation shall be done as per IRC:SP:91.</p> <p>b) Geotechnical and subsurface investigation and testing for tunnels shall be carried out through the geotechnical Consultants who have the experience of geotechnical and subsurface investigation in similar project.</p>
14.	4.12.1 (1)	<p>The Consultant shall also carry out detailed designs and prepare working designs for the following:</p> <p>a) cross sections at every 25 m intervals</p> <p>b) Slope stabilization and erosion control measures</p> <p>c) Design of protection/control structures in areas subject to subsidence, landslides, rock fall, rock slide, snow drifts, icing, scour, avalanche activity etc.</p> <p>d) Design of protective structures in slip prone and unstable areas</p> <p>e) Design of scenic overlooks, watering points etc.</p> <p>f) Safety features specific to hill roads</p>

15.	4.12.2 (1)	The Consultant shall evolve Design Standards and material specifications for the Study primarily based on IRC publications, MORT&H Circulars and relevant recommendations of the international standards for hill roads for approval by NHA.
	4.12.2 (2)	The Design Standards evolved for the project shall cover all aspects of detailed design including the design of geometric elements, pavement design, bridges and <del>and</del> .
16.	4.12.3	Wherever practicable/feasible hairpin bends and steep gradients shall be avoided by realignments, provision of structures or any other suitable provisions.
17.	4.12.4	While designing pavement for hill roads specific aspects relevant to hill regions like terrain & topographic conditions, weather conditions, altitude effects etc. shall be duly considered and suitably incorporated in design so that pavement is able to perform well for the design traffic and service life. Effects of factors like heavy rainfall, frost action, intensive snow and avalanche activity, thermal stresses due to temperature difference in day and night, damage by tracked vehicles during snow clearance operations etc. must also be considered along with traffic intensity, its growth, axle loads and design life.
18.	4.12.5(3)	The design of embankments should include the requirements for protection works and traffic safety features including features specific to hill roads.
19.	4.12.6	Design and Drawing of Tunnels: The Consultant shall prepare design and drawings for tunnels, if required as per the results of feasibility study, as per the relevant specifications of IRC:SP:91/MORT&H and other international specifications.
20.	4.12.7	a) Topography of hills generates numerous water courses and this coupled with continuous gradients of roads in hills and high intensity of rainfall calls for effective drainage of roads. The drainage system shall be designed to ensure that the water flowing towards the road surface may be diverted and guided to follow a definite path by suitable provision of road side drains, catch water drains, interceptors etc. and flow on valley side is controlled so that stability is not affected.  b) Further, adequate provision shall be made for sub-surface/subgrade drainage to take care of seepage through the adjacent hill face of the road & underground water flows.
21.	4.12.8	The Consultant shall design suitable traffic safety features and road furniture including traffic signals, signs, markings, overhead sign boards, crash barriers ,delineators etc. including any feature specific to hill roads. The locations of these features shall be given in the reports and also shown in the drawings.
22.	4.12.11	The Consultant shall make suitable designs and layout for miscellaneous works including rest areas, bus bays, vehicle parking areas, telecommunication facilities, scenic overlooks, watering points etc. wherever appropriate.

23.	10.9.3	<p>Volume II: Design Report :</p> <p>a) Inventory of protection measures and other structures b) Inventory of tunnels, if required.</p> <p>b) Proposed preliminary designs for tunnels, if required.</p> <p>Volume III: Drawings</p> <p>a) Drawings for protection/control measures and other structures</p> <p>b) Drawings for tunnels, if required.</p>
24.	10.9.3	<p>Volume II: Design Report (Part II)</p> <p>Part II of Design Report shall also deal with design of tunnels, if required and design of other protection/control structures.</p> <p>Volume IX: Drawing Volume</p> <p>This shall also include :</p> <p>a) Detailed working drawings for tunnels, if required.</p> <p>b) Detailed working drawings for protection/control structures</p>

## SUPPLEMENT II

### ADDITIONAL REQUIREMENTS FOR BRIDGES

Sr. No.	Clause No. of TOR	<i>Additional points</i>
1	4.1	For standalone bridge projects the scope of work shall include detailed design of approach road extending at least up to 2 km on either side of the bridge
1.	4.11.4.2(6)	<p><b>Model Studies for Bridges</b></p> <p><b>1. Objective</b> Physical/ Mathematical Model study for detailed Hydraulic / Hydrologic investigations regarding the proposed bridge for hydraulic design of the bridge and assessment and hydraulic design of required river training works.</p> <p><b>2. Methodology</b> Physical/Mathematical Model study shall be carried out at a reputed/recognized institution. The consultant will be responsible for identifying the institution, supplying Information /Documents /Data required for modal studies as indicated in para 4 below and coordinating the model study with the institution concerned</p> <p><b>3. Scope of Work</b></p> <p><b>3.1 Physical Model study</b> Physical modeling with appropriate model scale for Hydraulic and Hydrologic Investigations to:</p> <ul style="list-style-type: none"> <li>i) Finalize span arrangement causing uniformity in flow distribution, and work out the alignment and orientation of river training works and bridge axis.</li> <li>ii) Provide information on estimated/observed maximum depth of scour.</li> <li>iii) Provide information on required river training works for proposed bridge</li> <li>iv) Provide hydraulic design for the bridge and the required river training works.</li> <li>v) Quantify the general direction of river course through bridge, afflux, extent and magnitude of flood, effect of backwater, if any, aggradation/degradation of bed, evidence of scour etc. shall be used to augment the available hydrological data. The presence of flood control/irrigation structures, if affecting the hydraulic characteristics like causing obliquity, concentration of flow, scour, silting of bed, change in flow levels, bed levels etc. shall be studied and considered in Hydraulic design of</li> </ul>

	<p>design of proposed bridge. The details of any planned work in the immediate future that may affect the river hydraulics shall be studied and considered.</p> <p><b>3.2 Mathematical Model study</b></p> <p>Mathematical modeling for detailed Hydraulic / Hydrologic investigations regarding the proposed new bridge to:</p> <ul style="list-style-type: none"> <li>i) Finalize the site/location of the proposed new bridge based on mathematical modeling.</li> <li>ii) Provide information on estimated/observed maximum depth of scour.</li> <li>iii) Provide information on required river training works for proposed bridge</li> <li>iv) Provide hydraulic design for the bridge and the required river training works.</li> <li>v) Quantify the general direction of river course through bridge, afflux, extent and magnitude of flood, effect of backwater, if any, aggradation/degradation of bed, evidence of scour etc. shall be used to augment the available hydrological data. The presence of flood control/irrigation structures, if affecting the hydraulic characteristics like causing obliquity, concentration of flow, scour, silting of bed, change in flow levels, bed levels etc. shall be studied and considered in Hydraulic design of proposed bridge. The details of any planned work in the immediate future that may affect the river hydraulics shall be studied and considered.</li> </ul> <p><b>4. Information/Documents/Data required for Physical /Mathematical Model study</b></p> <ul style="list-style-type: none"> <li>i) Plan layouts showing the locations of the proposed bridge as well as the existing bridges /barrages etc., in the vicinity of the proposed bridge with the chainages with respect to a standard reference marked on it.</li> <li>ii) High flood discharges and corresponding flood levels at the locations of the existing bridges in the vicinity of the proposed bridge.</li> <li>iii) General arrangement drawing (GAD) of the existing bridges showing number of spans, pier and well dimensions, founding levels, maximum scour level, the design discharge and the HFL, guide bund details. On this, the plan form of the river course with the bridge alignment may also be shown as far as possible.</li> <li>iv) General arrangement drawing (GAD) of the proposed new bridge showing number of spans, pier and foundation dimensions. On this, the plan form of the river course with the bridge alignment may also be shown as far as possible.</li> </ul>
--	---

- |  |  |  |
|--|--|--|
|  |  | <p>v) River cross sections at 500m longitudinal spacing (maximum) up to a distance of 2 times the bridge total length on the upstream side and up to a distance equal to the bridge total length on the downstream with right bank and left bank clearly marked on it. At least one cross section to be provided at the location of the proposed bridge. At each cross section, the bed levels to be taken at a maximum lateral distance of 8 m in flow section and at 25 m in non-flow section respectively. The abrupt variations in the bed levels to be captured by taking measurements at closer locations both in longitudinal as well as lateral directions.</p> <p>vi) The cross sections, as far as possible, from high bank to high bank.</p> <p>vii) The longitudinal profile of the river along the length of the proposed alignment.</p> <p>viii) Size distribution of the river bed material and the bore log data at different locations at the site of the proposed bridge.</p> <p>ix) The series of annual peak flood of the river for at least 15 years period</p> |
|--|--|--|

## SUPPLEMENT-III

### ADDITIONAL REQUIREMENT FOR SAFETY AUDIT

The use of checklists is highly recommended as they provide a useful “aide memoire” for the audit team to check that no important safety aspects are being overlooked. They also give to the project manager and the design engineer a sense of understanding of the place of safety audit in the design process. The following lists have been drawn up based on the experience of undertaking systematic safety audit procedures overseas. This experience indicates that extensive lists of technical details has encouraged their use as “tick” sheets without sufficient thought being given to the processes behind the actions. Accordingly, the checklists provide guidelines on the principal issues that need to be examined during the course of the safety audits.

#### Stage F-During Feasibility Study

1. The audit team should review the proposed design from a road safety perspective and heck the following aspects

CONTENTS	ITEMS
Aspects to be checked	<ul style="list-style-type: none"> <li>A. Safety and operational implications of proposed alignment and junction strategy with particular references to expected road users and vehicle types likely to use the road.</li> <li>B. Width options considered for various sections.</li> <li>C. Departures from standards and action taken.</li> <li>D. Provision of pedestrians, cyclists and intermediate transport</li> <li>E. Safety implications of the scheme beyond its physical limits i.e. how the scheme fits into its environs and road Hierarchy</li> </ul>
A1 : General	<ul style="list-style-type: none"> <li><input type="checkbox"/> Departures from standards</li> <li><input type="checkbox"/> Cross-sectional variation</li> <li><input type="checkbox"/> Drainage</li> <li><input type="checkbox"/> Climatic conditions</li> <li><input type="checkbox"/> Landscaping</li> <li><input type="checkbox"/> Services apparatus</li> <li><input type="checkbox"/> Lay-byes</li> <li><input type="checkbox"/> Footpath</li> <li><input type="checkbox"/> Pedestrian crossings</li> <li><input type="checkbox"/> Access (minimize number of private accesses)</li> <li><input type="checkbox"/> Emergency vehicles</li> <li><input type="checkbox"/> Public Transport</li> <li><input type="checkbox"/> Future widening</li> <li><input type="checkbox"/> Staging of contracts</li> <li><input type="checkbox"/> Adjacent development</li> </ul>

A2 : Local Alignment	<ul style="list-style-type: none"> <li>☐ Visibility</li> <li>☐ New/Existing road interface</li> <li>☐ Safety Aids on steep hills</li> </ul>
A3 : Junctions	<ul style="list-style-type: none"> <li>☐ Minimise potential conflicts</li> <li>☐ Layout</li> <li>☐ Visibility</li> </ul>
A4 : Non-Motorised road users Provision	<ul style="list-style-type: none"> <li>☐ Adjacent land</li> <li>☐ Pedestrians</li> <li>☐ Cyclists</li> <li>☐ Non-motorised vehicles</li> </ul>
A5 : Signs and Lighting	<ul style="list-style-type: none"> <li>☐ Lighting</li> <li>☐ Signs/Markings</li> </ul>
A6 : Construction and Operation	<ul style="list-style-type: none"> <li>☐ Build ability</li> <li>☐ Operational</li> <li>☐ Network Management</li> </ul>

### Stage 1 - Completion of Preliminary Design

1. The audit team should review the proposed check the following aspects design from a road safety perspective and check the following aspects

CONTENTS	ITEMS
Aspects to be checked	<ul style="list-style-type: none"> <li>A. Safety and operational implications of proposed alignment and junction strategy with particular references to expected road users and vehicle types likely to use the road.</li> <li>B. Width options considered for various sections.</li> <li>C. Departures from standards and action taken.</li> <li>D. Provision of pedestrians, cyclists and intermediate transport</li> <li>E. Safety implications of the scheme beyond its physical limits i.e. how the scheme fits into its environs and road hierarchy</li> </ul>



B1 : General	<ul style="list-style-type: none"> <li>▫ Departures from standards</li> <li>▫ Cross-sectional variation</li> <li>▫ Drainage</li> <li>▫ Climatic conditions</li> <li>▫ Landscaping</li> <li>▫ Services apparatus</li> <li>▫ Lay-byes</li> <li>▫ Footpaths</li> <li>▫ Pedestrian crossings</li> <li>▫ Access (minimize number of private accesses)</li> <li>▫ Emergency vehicles</li> <li>▫ Public Transport</li> <li>▫ Future widening</li> <li>▫ Staging of contracts</li> <li>▫ Adjacent development</li> </ul>
B2 : Local Alignment	<ul style="list-style-type: none"> <li>▫ Visibility</li> <li>▫ New/Existing road interface</li> <li>▫ Safety Aids on steep hills</li> </ul>
B3 : Junctions	<ul style="list-style-type: none"> <li>▫ Minimise potential conflicts</li> <li>▫ Layout</li> <li>▫ Visibility</li> </ul>
B4 : Non-Motorised road users Provision	<ul style="list-style-type: none"> <li>▫ Adjacent land</li> <li>▫ Pedestrians</li> <li>▫ Cyclists</li> <li>▫ Non-motorised vehicles</li> </ul>
B5 : Signs and Lighting	<ul style="list-style-type: none"> <li>▫ Lighting</li> <li>▫ Signs/Markings</li> </ul>
B6: Construction and Operation	<ul style="list-style-type: none"> <li>▫ Build ability</li> <li>▫ Operational</li> <li>▫ Network Management</li> </ul>

## Stage 2 - Completion of Detailed Design

1. The audit team should satisfy itself that all issues raised at Stage 1 have been resolved. Items may require further consideration where significant design changes have occurred.
2. If a scheme has not been subject to a stage 1 audit, the items listed in Checklists B1 to B6 should be considered together with the items listed below.

CONTENTS	ITEMS
Aspects to be checked	A. Any design changes since Stage 1. B. The detailed design from a road safety viewpoint, including the road safety implications of future maintenance (speed limits; road signs and markings; visibility; maintenance of street lighting and
C1 : General	<input type="checkbox"/> Departures from standards <input type="checkbox"/> Drainage <input type="checkbox"/> Climatic conditions <input type="checkbox"/> Landscaping <input type="checkbox"/> Services apparatus <input type="checkbox"/> Lay-byes <input type="checkbox"/> Access <input type="checkbox"/> Skid-resistance <input type="checkbox"/> Agriculture <input type="checkbox"/> Safety Fences <input type="checkbox"/> Adjacent development
C2 : Local Alignment	<input type="checkbox"/> Visibility <input type="checkbox"/> New/Existing road interface
C3 : Junctions	<input type="checkbox"/> Layout <input type="checkbox"/> Visibility <input type="checkbox"/> Signing <input type="checkbox"/> Lighting <input type="checkbox"/> Road Marking <input type="checkbox"/> T,X,Y-junctions <input type="checkbox"/> All roundabouts <input type="checkbox"/> Traffic signals
	<input type="checkbox"/> Non-motorised vehicles
C4 : Non-Motorised road users Provision	<input type="checkbox"/> Adjacent land <input type="checkbox"/> Pedestrians <input type="checkbox"/> Cyclists

C5 : Signs and Lighting	<input type="checkbox"/> Advanced direction signs <input type="checkbox"/> Local traffic signs <input type="checkbox"/> Variable message signs <input type="checkbox"/> Other traffic signs <input type="checkbox"/> Lighting
C6 : Construction and Operation	<input type="checkbox"/> Buildability <input type="checkbox"/> Operational <input type="checkbox"/> Network Management

## Enclosure-I

### MANNING SCHEDULE

Sr. No	Key Personnel	Total Project Assignment 120 days		
		At site (man month)	At design office (man month)	Total Time Period (man month)
1	Team Leader Cum Senior Bridge Engineer	2.5	1.5	4
2	Bridge Engineer (3 Nos.)	1	1	2
3	Senior Highway cum Pavement Engineer	2.5	1.5	4
4	Material-cum-Geo-technical Engineer – Geologist	2	2	4
5	Senior Survey Engineer (3 Nos.)	1	1	2
6	Traffic and Safety expert	1.5	.5	2
7	Quantity Surveyor / Documentation Expert	2	2	4
8	Land Acquisition Expert	2.5	1.5	4
	<b>Total</b>	<b>12.5</b>	<b>9.5</b>	<b>22</b>

1. Consultants have to provide a certificate that all the key personnel as envisaged in the Contract Agreement have been actually deployed in the projects. They have to furnish the certificate at the time of submission of their bills to NHAI from time to time.

2. The requirement of tunnel/s is to be assessed strictly as per site requirement during the detailed study after mobilisation of Consultant on site.

In case Tunnels are to be constructed, necessary input of Tunnel Experts shall be provided in addition to above mentioned Manpower requirement.

Tunnel expert, if required, the remuneration may be provided equivalent to Team Leader remuneration and time period shall be decided by Regional Officer, concerned, NHAI.

3. The Consultant shall provide one Land Acquisition Expert along with allied team and supporting logistic as envisaged in Clause 5.1.5.1 of TOR for each 100 km stretches proposed for DPR preparation or part thereof

If delay in LA process occurs beyond the reasonable control of consultant, the extension of LA team staff/s along with logistic support/transportation shall be granted by Nodal Project Director and beyond further 6 months, Regional Officer, NHAI is empowered to grant extension to LA team staff/s.

## Enclosure-II

### Qualification and Experience Requirement of Key Personnel

#### Team Leader cum Senior Bridge Engineer

<b>i)</b>	<b>Educational Qualification</b>	
	Essential	Graduate in Civil Engineering or equivalent as approved by AICTE
	Desirable	Post graduate in Civil Engineering (Structure Engineering) {AICTE Approved}
<b>ii)</b>	<b>Essential Experience</b>	
	a) Total Professional Experience	Min. 15 years
	b) Experience in Bridge Projects	Min. 12 years in Planning, project preparation and design of <b>Bridges/Flyovers/Structures</b>
	c) Experience in similar capacity (Either as Team Leader cum Senior Bridge Engineer or in Similar capacity )	Bridge Engineer in highway design consultancy projects (2/4/6 lane NH/SH/Expressways) involving design of minimum two <b>major bridges</b> (length more than 200 m)
<b>iii)</b>	<b>Age Limit</b>	<b>65 years on the date of submission of proposal</b>

## Enclosure-II (contd.)

### QUALIFICATION AND EXPERIENCE REQUIREMENT OF KEY PERSONNEL

#### Bridge Engineer

i)	<b>Educational Qualification</b>	
	Essential	Graduate in Civil Engineering or equivalent
	<b>Desirable</b>	<b>Masters in Bridge Engineering / Structural Engineering</b>
ii)	<b>Essential Experience</b>	
	a) Total Professional Experience	Min. 10 years
	b) Experience in Bridge projects	Min. 08 years in project preparation and design of bridge projects.
	c) Experience in similar capacity	Bridge Engineer in highway design consultancy projects (2/4/6 lane NH/SH/Expressways) involving design of minimum two <b>major bridges</b> (length more than 200 m)
iii)	<b>Age Limit</b>	<b>65 years on the date of submission of Proposal</b>

## Enclosure-II (contd.)

### QUALIFICATION AND EXPERIENCE REQUIREMENT OF KEY PERSONNEL

#### Senior Highway cum Pavement Engineer

<b>i)</b>	<b>Educational Qualification</b>	
	Essential	<b>Degree in Civil Engineering</b>
	<b>Desirable</b>	<b>Masters in highway engineering/Transportation Engineering</b>
<b>ii)</b>	<b>Experience</b>	
	a) Total Professional Experience	Min. 10 years
	b) Experience in Highway projects	Minimum 08 years' experience in pavement design and maintenance of highways
	c) Experience in similar capacity	Pavement design for major highway projects (2/4/6 lane NH/SH/ Expressways) of minimum aggregate length of 80 km.
<b>iii)</b>	<b>Age Limit</b>	<b>65 years on the date of submission of Proposal</b>

## Enclosure-II (contd.)

### QUALIFICATION AND EXPERIENCE REQUIREMENT OF KEY PERSONNEL

#### Material Engineer - cum - Geotechnical Engineer cum Geologist

i)	<b>Educational Qualification</b>	
	Essential	Graduate in Civil Engineering or M.Sc. Geology
	<b>Desirable</b>	<b>Masters in Foundation Engineering / Soil Mechanics / Phd in Geology /Geo Tech Engineering</b>
ii)	<b>Essential Experience</b>	
	a) Total Professional Experience	Min. 10 years
	b) Experience in Highway Projects	Min. 7 years on similar projects in design and/or construction
	c) Experience in similar capacity	Material cum Geo-technical Engineer on highway projects (2/4/6 lane NH/SH/Expressways) of minimum aggregate length of 80 km.
iii)	<b>Age Limit</b>	<b>65 years on the date of submission of Proposal</b>



## Enclosure-II (contd.)

### QUALIFICATION AND EXPERIENCE REQUIREMENT OF KEY PERSONNEL

#### Senior Survey Engineer

<b>i)</b>	<b>Educational Qualification</b>	
	Essential	Graduate or equivalent in Civil Engineering or Diploma in Civil Engg or Diploma in Surveying
	Desirable	<b>Masters in Survey Engineering/ Surveying / Remote Sensing</b>
<b>ii)</b>	<b>Essential Experience</b>	
	a) Total Professional Experience	Min. 10 years
	b) Experience in Highway projects	Min. 8 years on similar projects in project preparation and construction & thorough understanding of modern computer based methods of surveying
	c) Experience in similar capacity	Survey Engineer for projects preparation of highway project (NH/SH/Expressways) involving 2/4/6- laning of minimum aggregate length of 80 km.
<b>iii)</b>	<b>Age Limit</b>	<b>65 years on the date of submission of Proposal</b>

**Enclosure-II (contd.)**

**QUALIFICATION AND EXPERIENCE REQUIREMENT OF KEY PERSONNEL**

**Traffic / Road Signage / Marking and Safety Expert**

<b>i)</b>	<b>Educational Qualification</b>	
	Essential	Graduate in Civil Engineering
	<b>Desirable</b>	<b>Masters in Traffic Engineering / Transportation Engineering / Transport Planning</b>
<b>ii)</b>	<b>Essential Experience</b>	
	a) Total Professional Experience	Min. 06 years
	b) Experience in Highway projects	Min. 05 years on similar projects.
	c) Experience in similar capacity	Traffic Engineer in highway Projects (NH/SH/Expressways) involving 2/4/6 laning of minimum aggregate length of 80 km.
<b>iii)</b>	<b>Age Limit</b>	<b>65 years on the date of submission of Proposal</b>



## Enclosure-II (contd.)

### QUALIFICATION AND EXPERIENCE REQUIREMENT OF KEY PERSONNEL

#### Quantity Surveyor/Documentation Expert

i)	<b>Educational Qualification</b>	
	Essential	Graduate or equivalent in Civil Engineering / Certificate course from 'Institution of Quantity Surveying'
	<b>Desirable</b>	
ii)	<b>Essential Experience</b>	
	a) Total Professional Experience	Min. 10 years
	b) Experience in Highway Projects	Min. 8 years in Preparation of Bill of Quantities, Contract documents and documentation for major highway projects involving two/ four laning
	c) Experience in similar capacity	Quantity Surveyor / Documentation Expert in highway projects (NH/SH/Expressways) involving two/four/six laning of minimum aggregate length of 80 km.
iii)	<b>Age Limit</b>	<b>65 years on the date of submission of Proposal</b>

## Enclosure-II (contd.)

### QUALIFICATION AND EXPERIENCE REQUIREMENT OF KEY PERSONNEL

#### Land acquisition expert

i)	Educational Qualification	
	Essential	Graduate or equivalent
ii)	Essential Experience	
	a) Total Professional Experience	15 years as Deputy-Tehsildar or above Desirable: Ex- revenue officers like Ex-ADM/SDM, Ex-Tehsildar, Ex-Deputy-Tehsildar etc
	b) Role specific experience	Min 10 years in Land acquisition for government/ authority projects
iii)	Age Limit	65 years on the date of submission of bid



## Enclosure-III

### Schedule for submission of Reports and Documents

Stage No.	Activity	No. of copies	Time Period in days from date of commencement
1	<b>Monthly Reports</b>	3	By 10 <sup>th</sup> day of every month
2	<b>Inception Report</b>		
	(i) Draft Inception Report including QAP document	3	10
	(ii) Inception Report including QAP document	3	15
3	<b>F.S. REPORT</b>		
	i) Draft Feasibility Study Report including option study report including draft 3(a) report	4	25
	ii) Comments of client	1	30
	iii) Final Feasibility Study Report incorporating compliance of comments of Client	4	<b>36</b>
4	<b>LA &amp; Clearances I Report</b>		
	i) Draft LA & Clearances I Report including draft 3(A) report	4	42
	ii) Comments of client	1	<b>48</b>
	iii) Final LA & Clearances I Report incorporating compliance of comments of Client	4	55
5	<b>Detailed Project Report</b>		
	i) Draft DPR	4	<b>120</b>
	ii) Comments of client	1	84
	iii) Final DPR incorporating compliance of comments of Client	6	<b>96</b>

6	<b>Technical Schedules</b> i) Draft Technical Schedules ii) Comments of client iii) Final technical schedule	4 1 6	<b>72</b> <b>84</b> <b>96</b>
7	<b>Land Acquisition II Submission of draft 3D publication report</b>	4	<b>72</b>
8	<b>Land Acquisition III, Award determination (3G)</b>		<b>96</b>
9	<b>Project Clearances &amp; LA IV Report</b>  <b>Approval of Project clearances</b> from Concerned agencies e.g. from MOEF; Rly for approval of GAD and detail engineering drawing of ROB/RUB; Irrigation Dept., Utility Report and Possession of Land	6  Original letters from the concerned agencies and 5 photocopies of each	<b>120</b>

The checklist for different stages of submission of report has been enclosed as under and the same shall be appended with proper references and page numbering. The checklist/s shall be appended with the report without which no payment shall be made.



**Schedule for approval of Reports and Documents by PD after submission by Consultant.**

<b>Stage No.</b>	<b>Activity</b>	<b>Time Period in days from date of submission of Comment and acceptance by PD/RO</b>
1	<b>Inception Report</b>	5 days
2	<b>Feasibility Study Report</b> i) Draft Feasibility Study Report including option study report including draft 3(a) report  ii) Final feasibility Study report	5 days  8 days
3	<b>LA &amp; Clearances Report</b>  i) Draft LA & Clearances Report  ii) Final LA & Clearances Report incorporating compliance of comments of Client	7 days  5 days
4	<b>Detailed Project Report</b> i) Draft DPR  ii) Final DPR incorporating compliance of comments of Client	10 days  5 days
5	<b>Technical Schedules</b>  i) Draft Technical Schedules  ii) Final technical schedule	12 days  5 days

The checklist for different stages of submission of report has been enclosed as under and the same shall be appended with proper references and page numbering. The checklist/s shall be appended with the report without which no payment shall be made.

## **Enclosure IV: Formats for submission of Reports and Documents**

### **1. Standard formats for deliverables**

- i. During the course of the assignment to prepare detailed project report, several reports, drawings and documents will need to be submitted by the consultants to NHAI.
- viii. For the purposes of submission, format requirements have been laid out for some of the reports and drawing deliverables in this enclosure, which shall be adhered to strictly
- ix. In addition, consultants are to align and agree with NHAI officials the format of submission for all reports, during the inception stage as mentioned in clause 10.2 of this terms of reference

### **2. Format for submission of report deliverables**

#### **2.1 Printed hard copies of reports**

- i. All reports and documents shall be submitted in both printed hard copy and digital formats
- ii. For hard copies, the consultant shall submit bound volumes (and not in spiral binding form) after completion of each stage of work as per the schedule and in the number of copies as given in Enclosure III

#### **2.2 Digital copies of reports**

1. Every report shall also be submitted in digital format to the authority in the following formats:
  - i. The final report as submitted in the portable document format (.pdf)
  - ii. An editable document in the relevant Open Document Format for Office Applications (ODF) and if available the relevant Microsoft Office document format (MS Office)
  - iii. All tables and models used to and referred to in the reports shall also be submitted as spread-sheets in the relevant ODF format and MS Office format
  - iv. The digital copies of reports shall be submitted in the form of removable storage devices (CD or USB pen drive) and also hosted on a secured online document storage and retrieval platform as described in clause 2 Data products
2. The removable storage device submitted at each deliverable stage shall contain:
  - i. Reports for that stage
  - ii. All draft and final reports previously submitted
  - iii. Correspondence with NHAI
  - iv. Clients' comments on submitted reports
  - v. Any communication, letters and approvals to and from other government and local agencies and any other relevant body
  - vi. An updated index of all the contents on the removable storage device
3. Every submission will be accompanied by a table of contents and index of all documents submitted for ease of reference

### **2 Data products**

1. During the course of the assignment, the consultant shall perform several surveys and collect data that will be used for the design of the road and delivered to the client.

2. Consultants are encouraged to keep commonly available software and data packages, and typical uses for data while deciding final formats of data within the constraints of this document or where a format has not been defined
3. As required in clause **Error! Reference source not found. Error! Reference source not found.**, consultants are required to agree with NHA1 all actual data formats proposed to be used for the project
4. In order to standardise data formats and simplify hand over and re-use of data, some requirements for minimum content and format are laid down below.

Sr No	Data product	Contents required (definition)	Data format
0	Formats to be used	List of data, drawing and design outputs, reporting format, digital format suggested, key data to be included (column headers), units and system to be used	CSV or ODF sheet, .xlsx optional
1	Traffic surveys		
1.1	List of traffic survey points	Point no, location coordinates (lat, long), location of survey point, chainage, no lanes/type of junction, type of survey, date of survey, length of survey, any commentary, equipment/technique used, link to survey output	CSV or ODF sheet, .xlsx optional
1.2	Classified traffic volume count survey	Survey point, survey location, location id (ihmcl), no of lanes, chainage, location coordinates (lat, long), date, time and period of survey	Raw data: IHMCL Traffic survey data format Processed, corrected with AADT: CSV or ODF sheet, .xlsx optional
1.3	O-D, turning movement, axle load and other surveys	Survey point, survey location, location lat, long, chainage, date, time, period of survey, technique/equipment used in addition to the survey data itself	CSV or ODF sheet, .xlsx optional
2	Engineering surveys and investigations		
2.1	Raw DGPS data	Notes must contain Date, time of survey, equipment used, corrections applied is any. Data: Survey benchmarks, benchmark points, location data points	CSV or ODF, Receiver Independent Exchange Format (RINEX)
2.2	LiDAR point cloud	Notes must contain Date, time of survey, equipment, summary post processing applied. Data: Survey benchmarks, data points, point cloud of entire project corridor as defined in	LASer file format for exchange CSV sheet, .xlsx optional
2.3	Images	360 Deg/ ortho images of entire project road way	Geographic Tagged Image File Format (GeoTIFF)
2.4	Video	Traverse video of entire project length	Audio video interleave (.avi) or MPEG-4 file (.mp4)

Sr No	Data product	Contents required (definition)	Data format
2.5	Topographic map + contours	1:1000 scale map with 50 cm contours with roadway marked on maps	Contours: geo-referenced shape files (.shp) or .dxf files, .dwg/.dgn files options
2.6	Digital elevation model	Digital terrain modeled from aerial and ground surveys	Digital elevation model in USGS Spatial Data transfer standard (SDTS) format
2.7	Longitudinal and cross sections	Location of cross section - existing, design chainage, lat, long, Cross section drawing	.dxf files, .dwg/.dgn files options
2.8	As-is road map	3D digital map of as-is project highway containing earth surface, road layers, utilities, buildings and trees with feature data extracted and mapped in layers, marked on the map and tabulated data provided separately. All road, surface, sub surface inventory, pavement investigation and soil survey data to be super-imposed as layers	Digital terrain model and maps in LandXML/.dxf format, .dwg/.dgn files options Separate CSV or ODF sheet, .xlsx optional of feature data in addition to map
2.9	Details of utility	type of utility, no, class and category of utility installation (e.g. 66 kV xlpe), location, distance from centerline, user agency	CSV or ODF sheet, .xlsx optional
2.10	Utility maps	geo-referenced schematic map, existing and design road centerline, type of utility, size, no, class and category	georeferenced shape files (.shp) and drawings in .dxf format
2.11	Road inventory surveys	All data as required in clause 4.11.3.1, geo-referencing for each row of data in lat, long form	CSV or ODF sheet
2.12	Pavement investigation	Test pit reference id, location, chainage, geo-reference (lat, long), pavement composition - layer no, material type, thickness, sub grade type, and condition	CSV or ODF sheet
2.13	Pavement condition survey	Data as required in clause 4.11.3.2, along with location/chainage and geo-reference for all data	CSV or ODF sheet
2.14	Pavement structural strength	FWD results as per IRC guidelines, geo-referencing for test points	CSV or ODF sheet
2.15	Sub-grade and soil strength	In the format of the testing lab, summary details must be tabulated and must include: test pit no, location, chainage, lat/long, date, time of test, tester/lab details, in-situ density, moisture content, field CBR, characterization, in-lab moisture and density, lab CBR	Summary in CSV or ODF sheet
3	Proposed roadway designs		
3.1	Proposed	Georeferenced centerline horizontal and vertical	Geometry or shape files

Sr No	Data product	Contents required (definition)	Data format
	alignment geometry	alignment for the road To be presented superimposed on surface map, satellite imagery and digital elevation model of region	: .shp/.dxf, .dwg/.dgn files options
3.2	Final alignment geometry	Georeferenced centerline horizontal and vertical alignment for the road. Additional detail on lanes, super elevation, junctions, structures, under/overpasses, PUP/CUP, wayside amenities etc	Geometry or shape files : .shp/.dxf, .dwg/.dgn files options
3.3	Proposed roadway model	Proposed digital roadway model and design data-including embankment, road way, road layers, roadside amenities, signals, road furniture, markings and other construction elements in 3D	.dxf/.dtm
3.4	Proposed structures	Geo referenced location and alignment, 3D model of structure and appurtenances, cross section, plan and profile drawings for construction as per IRC	.dxf/.dtm
3.5	Proposed highway cross sections	Roadway cross sections for homogenous sections	.dxf files Digital surface model in .dxf format
4	Other deliverables		
4.1	Digitized cadastral maps	Digitized revenue map overlaid with key landmarks, land size, survey number and ownership data. min 1:1000 scale map with >1mm accuracy	Geometry or shape files : .shp/.dxf, .dwg/.dgn files options
4.2	Financial analysis	Spreadsheet model with instructions, index and containing all inputs and assumptions, time series construction and operating costs, revenues, financing and equity cash flows, NPV/IRR, sensitivity scenarios and results	ODF sheets, MS office .xlsx optional

### 3 Online hosting and archival of deliverables

#### 3.1 Hosting deliverables online

- i. The consultant shall store all deliverables from this assignment on a secure online file hosting platform that is remotely accessible by authorised users on the world wide web
- ii. The consultant shall provide read only access to all relevant officers of NHAI and provide further access to additional users as and when requested by NHAI
- iii. Consultant shall provide a point of contact for access to these files, solving any technical issues and shall respond to all requests in a timely manner
- iv. Consultant shall ensure that the files are hosted in a platform that conforms to any file hosting and file sharing security standards as may be laid down by the government of India

### 3.2 **Deliverables to be hosted**

- i. Data and deliverables to be hosted in an online accessible format shall include but not be limited to:
- ii. All draft and final deliverables in the digital formats prescribed in this TOR and in file formats in wide use where formats are not specified
- iii. Data, images and videos from all surveys and investigations conducted of this enclosure
- iv. All correspondence to and from NHAI including clients' comments on submitted reports
- v. Any communication, letters and approvals to and from other government local agencies and any other relevant body
- vi. The platform shall also contain an index and table of contents of information being hosted for ease of access and use

### 3.3 **Time period and costs**

- i. Access to above mentioned files will be provided till the end of construction (final commercial operations date of contractor/ concessionaire) of all packages that form a part of this assignment at the cost of the consultant
- ii. Access to additional users shall also be at no additional cost to the authority

## APPENDIX-II

### Proof of Eligibility

#### Form-E1

Letter of Proposal (On Applicant's letter head)

(Date and Reference)

To, \*\*\*\*\*  
\*\*\*\*\*  
\*\*\*\*\*

Sub: Appointment of Consultant for preparation of Detailed Project Report for .....

Dear Sir,

With reference to your RFP Document dated ....., I/we i.e M/s-----  
----- (Name of Bidder) having examined all relevant documents and understood their contents, hereby submit our Proposal for selection as Consultant. The proposal is unconditional and unqualified.

2. All information provided in the Proposal and in the Appendices is true and correct and all documents accompanying such Proposal are true copies of their respective originals.

3. This statement is made for the express purpose of appointment as the Consultant for the aforesaid Project.

4. I/We shall make available to the Authority any additional information it may deem necessary or require for supplementing or authenticating the Proposal.

5. I/We acknowledge the right of the authority to reject our application without assigning any reason or otherwise and hereby waive our right to challenge the same on any account whatsoever.

6. I/We certify that in the last three years, we or any of our Associates have neither failed to perform on any contract, as evidenced by imposition of a penalty by an arbitral or judicial authority or a judicial pronouncement or arbitration award against the Applicant, nor been expelled from any project or contract by any public authority nor have had any contract terminated by any public authority for breach on our part.

7. I/We understand that you may cancel the Selection Process at any time and that you are neither bound to accept any Proposal that you may receive nor to select the Consultant, without incurring any liability to the Applicants in accordance with Clause 1.7 of the RFP document.

8. I/We declare that we/any member of the consortium, are/is not a Member of any other Consortium applying for Selection as a Consultant.
9. I/We certify that in regard to matters other than security and integrity of the country, we or any of our Associates have not been convicted by a Court of Law or indicted or adverse orders passed by a regulatory authority which would cast a doubt on our ability to undertake the Consultancy for the Project or which relates to a grave offence that outrages the moral sense of the community.
10. I/We further certify that in regard to matters relating to security and integrity of the country, we have not been charge-sheeted by any agency of the Government or convicted by a Court of Law for any offence committed by us or by any of our Associates.
11. I/We further certify that no investigation by a regulatory authority is pending either against us or against our Associates or against our CEO or any of our Directors/Managers/employees.
12. I/We hereby irrevocably waive any right or remedy which we may have at any stage at law or howsoever otherwise arising to challenge or question any decision taken by the Authority [and/ or the Government of India] in connection with the selection of Consultant or in connection with the Selection Process itself in respect of the above mentioned Project.
13. The Bid Security of Rs. \*\*\*\*\* (Rupees \*\*\*\*\* ) in the form of a Bank Guarantee is attached, in accordance with the RFP document.
14. I/We agree and understand that the proposal is subject to the provisions of the RFP document. In no case, shall I/we have any claim or right of whatsoever nature if the Consultancy for the Project is not awarded to me/us or our proposal is not opened or rejected.
15. I/We agree to keep this valid for 120 (One hundred and twenty) days from the Proposal Due Date specified in the RFP.
16. A Power of Attorney in favor of the authorized signatory to sign and submit this Proposal and documents is attached herewith.
17. In the event of my/our firm/consortium being selected as the Consultant, I/we agree to enter into any Agreement in accordance with the form Appendix V of the RFP. We agree not to seek any changes in the aforesaid form and agree to abide by the same.
18. I/We have studied RFP and all other documents carefully and also surveyed the Project site. We understand that except to the extent as expressly set forth in the Agreement, we shall have no claim, right or title arising out of and documents or information provided to us by the Authority or in respect of any matter arising out of or concerning or relating to the Selection Process including the award of Consultancy.
19. The Proof of Eligibility and Technical proposal are being submitted in separate covers in hard copy and they are being submitted online also. Financial Proposal is being submitted online only. This Proof of Eligibility read with Technical Proposal and



Financial Proposal shall constitute the Application which shall be binding on us.

20. I/We agree and undertake to abide by all the terms and conditions of the RFP Document. In witness thereof, I/we submit this Proposal under and in accordance with the terms of the RFP Document.

Yours faithfully,  
(Signature, name and designation of the authorized signatory)  
(Name and seal of the Applicant/Lead Member)

## Form-E2/T3

**FIRM'S REFERENCES**Relevant Services Carried out in the Last Seven Years (2010-11 onwards) Which Best Illustrate Qualifications

The following information should be provided in the format below for each reference assignment for which your firm, either individually as a corporate entity or as one of the major companies within a consortium, was legally contracted by the client:

Assignment Name:		Country:
Location within Country :		Professional Staff Provided by your firm:
Name of Client :		No. of Staff :
Address :		No. of Staff Months :
Start Date (Month / Year)	Completion Date (Month / Year)	Approx. Value of Services : (in INR/current USD) :
Name of JV/Association Firm(s) if any :		No. of Months of Professional Staff provided by Associated Firm(s)
Status of your Company in the Assignment i.e., Sole/Lead Member/Other Member/Associate		
Narrative Description of Project :		
Description of Actual Services Provided by your Company:		

**Signature of Authorized Representative**

**(Certificate from Employer regarding experience should be furnished)**

Form- E3

**Financial Capacity of the Applicant**

Name of Applicant:

Sr. No.	Financial Year	Annual Revenue (Rs/US \$ in million)
1	2016-17	
2	2015-16	
3	2014-15	
4	2013-14	
5	2012-13	

**Certificate from the Statutory Auditor<sup>\$</sup>**

This is to certify that ----- (name of the Applicant) has received the payments shown above against the respective years on account of Consultancy Services.

Name of the audit firm Seal of the audit firm Date

(Signature, name and designation of the authorized signatory)

<sup>\$</sup>In case the Applicant does not have a statutory auditor, it shall provide the certificate from its chartered accountant that ordinarily audits the annual account of the Applicant.

**Note:**

Please do not attach any printed Annual Financial Statement.

Form- E4

**BANK GUARANTEE FORMAT FOR BID SECURITY**

(To be stamped in accordance with Stamp Act if any, of the country of issuing bank)

Ref.: Tender No. \_\_\_\_\_, dated \_\_\_\_\_

Bank Guarantee: Date:

WHEREAS, \_\_\_\_\_ (Name of Bidder) \_\_\_\_ (hereinafter called "the bidder") has submitted his bid dated \_\_\_\_\_ (date) for the Tender No. \_\_\_\_\_, dated \_\_\_\_\_ (hereinafter called "the Bid". KNOW ALL MEN by these presents that We, \_\_\_\_\_ [Name of Bank] of \_\_\_\_\_ [Name of Country] having our registered office at \_\_\_\_\_ (hereinafter called "the Bank") are bound unto \_\_\_\_\_ [name of employer] (hereinafter called "the Employer") in the sum of Rs. \_\_\_\_\_ (Rupees \_\_\_\_\_ Lakhs only) for which payment will and truly to be made to the said employer the bank binds himself, his successors and assigns by these presents. SEALED with the Common Seal of the said Bank this \_\_\_\_\_ day of \_\_\_\_\_ 201\_.

THE CONDITIONS of this obligation are:

1. If the Bidder withdraws his Bid during the period of bid validity specified in the Bid document; or
2. If the Bidder does not accept the correction of arithmetical errors of his Bid Price in accordance with the Instructions to Bidder; or
3. If the Bidder having been notified of the acceptance of his Bid by the Employer during the period of bid validity,
  - a. fails or refuses to execute the Form of Agreement in accordance with the Instructions to Bidders, if required; or
  - b. fails or refuses to furnish the Performance Security, in accordance with the letter of invitation, we undertake to pay the Employer up to the above amount upon receipt of his first written demand, without the Employer having to substantiate his demand, provided that in his demand the Employer will note that the amount claimed by him is due to him owing to the occurrence of one or any of the conditions, specifying the occurred condition or conditions.

This Guarantee will remain in force up to and including the date 150 (one hundred and fifty) days after the deadline for submission of bids as such deadline is stated in the Instructions to Bidders or as it may be extended by the Employer, notice of which extension(s) to the Bank is hereby waived. Any demand in respect of this Guarantee should reach the Bank not later than the above date.

Notwithstanding anything contained herein before, our liability under this guarantee is restricted to \_\_\_\_\_ Rs. \_\_\_\_\_ (Rs. \_\_\_\_\_) and the guarantee shall remain valid till \_\_\_\_\_. Unless a claim or a demand in writing is made upon us on or before

\_\_\_\_\_ all our liability under this guarantee shall cease

DATE \_\_\_\_\_

SIGNATURE OF THE BANK \_\_\_\_\_

SEAL OF THE BANK \_\_\_\_\_

SIGNATURE OF THE WITNESS \_\_\_\_\_

Name and Address of the Witness \_\_\_\_\_

The bank guarantee shall be issued by a bank (Nationalized/Scheduled) located in India

(Form-T1)

**TECHNICAL PROPOSAL**

FROM:

TO:

---

---

---

---

---

---

---

---

Sir:

Subject Consultancy Service for

---

---

**Regarding Technical Proposal**

I/We \_\_\_\_\_ (name of Bidder) Consultant/  
Consultancy firm herewith enclose Technical Proposal for selection of my/our  
firm/organization as Consultant for \_\_\_\_\_

Yours faithfully,  
Signature  
Full Name  
Designation  
Address

(Authorized Representative)

(Form-T-2)

**Details of projects for which Technical and Financial Proposals have been submitted**

Sl. No.	<i>Name of Project</i>	Consultancy Package No.	Names of Proposed Key Personnel
1			
2			
3			
4			

**FIRM'S REFERENCES****Relevant Services Carried out in the Last Seven Years Which Best Illustrate Qualifications**

The following information should be provided in the format below for each reference assignment for which your firm, either individually as a corporate entity or as one of the major companies within a consortium, was legally contracted by the client:

Assignment Name:		Country:
Location within Country :		Professional Staff Provided by your firm:
Name of Client :		No. of Staff :
Address :		No. of Staff Months :
Start Date (Month / Year)	Completion Date (Month / Year)	Approx. Value of Services : (in INR/current USD) :
Name of JV/Association Firm(s) if any :		No. of Months of Professional Staff provided by Associated Firm(s)
Status of your Company in the Assignment i.e., Sole/Lead Member/Other Member/Associate		
Narrative Description of Project :		
Description of Actual Services Provided by your Company:		

**Signature of Authorised Representative**

**(Certificate from Employer regarding experience should be furnished)**



**SITE APPRECIATION**

Shall give details of site as per actual site visit and data provided in RFP and collected from site supported by photographs to demonstrate that responsible personnel of the Consultant have actually visited the site and familiarized with the salient details/complexities and scope of services.

**Composition of the Team Personnel and the task Which would be assigned to each Team Member**

I. Technical/Managerial Staff

---

Sr .No.	Name	Position	Task Assignment
1.			
2.			
3.			
4.			
....			
....			
....			

---

II. Support Staff

---

Sr. No.	Name	Position	Task Assignment
1.			
2.			
3.			
4.			
....			
....			
....			

**APPROACH PAPER ON METHODOLOGY PROPOSED FOR PERFORMING THE  
ASSIGNMENT**

The approach and methodology will be detailed precisely under the following topics.

- 1) Methodology for services, surveying, data collection [not more than 2 pages]  
and analysis
- 2) Quality Assurance system for consultancy assignment [not more than 1 page]
- 3) The key challenges foreseen and proposed solutions will be detailed precisely  
under the following topics
  - a) proposed alignment and bypass required
  - b) land acquisition requirements
  - c) access control, rehabilitation of existing road, drainage and utilities
  - d) adoption of superior technology along with proof (to be submitted in Form T9)

Replies to items 3) a) to c) should be limited to six A4 size pages in 1.5 space and 12 font  
including photographs, if any

---

**Details of Material Testing Facility**

1. State whether the Applicant has in-house Material Testing Facility Available / Outsourced / Not Available
2. In case answer to 1 is Available, attach a list of Lab equipment and facility for testing of materials and location of laboratory
3. In case laboratory is located at a distance of more than 400 km from the project site, state arrangements made / proposed to be made for testing of materials
4. In case answer to 1 is Outsourced / Not Available state arrangements made / proposed to be made for testing of materials.

**Facility for Field investigation and Testing**

1. State whether the Applicant has in-house Facility for
  - a) Geo-technical investigation Available (created in-house at site)/ Outsourced/ Not Available
  - b) Pavement investigation Available (created in-house at site)/ Outsourced/ Not Available
2. In case answer to 1 is Available (created in-house at site) a list of field investigation and testing equipments available in-house
3. In case answer to 1 is Outsourced/ Not Available arrangements made/proposed to be made for each of above Field investigation and testing
4. For experience in LiDAR or better technology for topographic survey, GPR and Induction Locator or better technologies for detection of sub-surface utilities and digitization of cadastral maps for land acquisition, references need to be provided in following format:

**REFERENCES**

Relevant Services Carried Out Which Best Illustrate Qualifications

The following information should be provided in the format below for each reference assignment for which your firm, either individually as a corporate entity or as one of the major companies within a consortium, was legally contracted by the client:

Assignment Name:		Country:
Location within Country :		Professional Staff Provided by your firm:
Name of Client :		No. of Staff :
Address :		No. of Staff Months :
Technology Used:		
Start Date (Month / Year)	Completion Date (Month / Year)	Approx. Value of Services : (in INR/current USD) :
Name of JV/Association Firm(s) if any :		No. of Months of Professional Staff provided by Associated Firm(s)
Status of your Company in the Assignment i.e., Sole/Lead Member/Other Member/Associate		
Narrative Description of Project :		
Description of Actual Services Provided by your Company:		

**Signature of Authorised Representative**

**(Certificate from Employer regarding experience should be furnished)**

**Office Equipment and software**

**Attach a list of office equipment and software owned by the Applicant**

**(Curriculum Vitae as per INFRACON)**

**CVs of the Key Personnel should be uploaded on INFRACON and the hard copies of the CVs as uploaded on the INFRACON is to be submitted along with the Technical Proposals.**

### **UNDERTAKING FROM THE PROFESSIONAL**

I, ..... (Name and Address) have not left any assignment with the consultants engaged by MORT&H/ NHAI for any continuing works of MORT&H/NHAI without completing my assignment. I will be available for the entire duration of the current project (named.....). If I leave this assignment in the middle of the completion of the work, I may be debarred for an appropriate period to be decided by NHAI. I have also no objection if my services are extended by NHAI for this work in future.

### **UNDERTAKING FROM CONSULTING FIRM**

The undersigned on behalf of ..... (name of consulting firm) certify that Shri.....(name of the proposed personnel and address) to the best of our knowledge has not left his assignment with any consulting firm engaged by MORT&H /NHAI for the ongoing projects. We understand that if the information about leaving the past assignment with NHAI without completing his assignment is known to NHAI, NHAI would be at liberty to remove the personnel from the present assignment and debar him for an appropriate period to be decided by NHAI.



(Form-I)

FINANCIAL PROPOSALS

FROM:

TO:

\_\_\_\_\_  
\_\_\_\_\_  
\_\_\_\_\_

\_\_\_\_\_  
\_\_\_\_\_  
\_\_\_\_\_

Sir:

Subject: Consultants' Services for

\_\_\_\_\_  
\_\_\_\_\_

Regarding Price Proposal

I/We \_\_\_\_\_ Consultant/consultancy firm  
herewith enclose \*Price Proposal for selection of my/our firm/organization as Consultant  
for \_\_\_\_\_

Yours faithfully,

Signature \_\_\_\_\_

Full Name \_\_\_\_\_

Designation \_\_\_\_\_

Address \_\_\_\_\_

(Authorized Representative)

**\*The Financial proposal is to be filled strictly as per the format given in RFP.**

(Form-II)

**Format of Financial Proposal**  
**Summary of Cost in Local Currency**

No.	Description	Amount (LC)* (INR)
I	<b><u>Local Consultants</u></b> Remuneration for Local Staff (inclusive of per diem allowance)	
II	Support Staff (inclusive of per diem allowance)	
III	Transportation	
IV	Duty Travel to Site	
V	Office Rent	
VI	Office Supplies, Utilities and Communication	
VII	Office Furniture and Equipment (Rental)	
VIII	Reports and Document Printing	
IX	Surveys & Investigations	
A	Topographical Survey	
B	Investigations	
C	Net Work Survey and GPR	
X	Cost of supply and fixing Boundary Pillars	
	<b>Subtotal Local Consultants :</b>	
	<b>Foreign Consultants</b>	
F-I	Remuneration for Expatriate Staff	
F-II	Mobilization and Demobilization	
	Total Cost Net of Tax :	
Taxes and Duties	I. Income Tax (Expatriate) II. Other Taxes/ Duties (if any) Specify clearly	
	Total cost net of Goods & service tax**	
	Goods & Service Tax	
	<b>TOTAL COSTS (Including GST)</b>	

LC\* Local Currency

\*\* Total Cost Net of Goods & Service Tax shall be considered for financial evaluation

Note: No escalation will be payable during the services

**Insurances shall not be allowed separately. These will be incidental to main items.**

***Rates for all items shall be quoted in figures as well as in words.***

(Form-III)

Estimate of Local Currency Costs

I. Remuneration for Local Staff (including per diem allowance)

Sr. No.	Position	Name	Rate (INR)	Staff Month	Amt.(INR)
	Professional Staff				
1	Team Leader cum Senior Bridge Engineer			4	
2	Bridge Engineer (3 Nos)			3x2 = 6	
3	Senior Highway cum Pavement Engineer			4	
4	Material-cum-Geotechnical Engineer- Geologist			4	
5	Senior Survey Engineer (3 Nos)			3x2 = 6	
6	Traffic and Safety Expert			2	
7	Quantity Surveyor/ Documentation Expert			4	
8	Land Acquisition Expert			4	
	Sub-Total:				
	Sub-Professional Staff	(To be assessed by Consultant as per requirement of assignment and one sub-professional be a fresh graduate)			
1					
2					
3					
4					
5					
6					
7					
	Sub-Total:				
	TOTAL				

## II. Support Staff

No.	Position	Name	Staff Months	Billing Rate( INR)	Amount ( INR)
1	Office Manager				
2	Typist				
3	Office Boy				
4	Night Watchman				
				<b>Total :</b>	

## III. Transportation (Fixed costs)

S. No	Description	Qty.	Nos. of months	Rate/ Month (INR)	Amount (INR)
1	The vehicles provided by the Consultants shall include the cost for rental, drivers, operation, maintenance, repairs, insurance, etc.  A. For use of consultants				
	<b>Total</b>				

## IV. Duty Travel to Site (Fixed Costs)

Trips	NO	Rate (INR)	Amount (INR)

## V. Office Rent (Fixed Costs)

The rent cost includes maintenance, cleaning, repairs, etc.  
months x \_\_\_\_\_

**Total**\_\_\_\_\_

## VI. Office Supplies, Utilities and Communication (Fixed Costs)

No.	Item	Months	Monthly Rate (INR)	Amount In INR.
1	Office Supplies Drafting			
2	Supplies Computer			
3	Running Costs			
4	Domestic and International Communication			

TOTAL:-----

## VII. Office Furniture and Equipment (Rental)

No.	Description	Unit	Quantity	Rate ( INR)	Amount (INR )
1	Office Furniture and Equipment		LS		
				Total	

## VIII. Reports and Document Printing

No.	Description	No. of Copies	Rate per Copy ( INR. )	Amount (INR.)
1	Monthly Report	3 Per Month		
2	Inception Report & QAP	3		
3	Environment and Social Impact Screening Report	4		
4	Draft Feasibility Report	4		
5	Final Feasibility Report	6		
6	Strip Plan with L.A. Reports	6		
7	Draft LA and Clearances I Report	4		
8	Final LA and Clearances I Report	4		
9	Draft Environmental Assessment report & RAP	4		
10	Final Environmental Assessment report & RAP	6		
11	Draft Detailed Design Report & Drawings etc. Draft EMP	4 4		
12	Draft Bidding Documents	4		

13	Final Detailed Project Report with Bill of Quantities, Cost Estimates, Updated Drawings etc. Final EMP	6		
14	Final Bidding Documents	6		
15	Draft 3(a) ,3(A) and 3(D) notification for land acquisition ( 3 copies each)	9		
16	LA & Clearances II Report	6		
			<b>Total</b>	

## IX. Survey and Investigation

### A. Topographical Survey (Fixed Rate)

No.	Item	Kms	Rate per Km (INR)	Amount (INR)
1	Topographic Survey including hire charges for equipment and supply of survey teams comprising of project survey filed staff etc. inclusive of cost of materials, labourer			
2	Detailed topographic surveys using mobile/ aerial LiDAR or better technology			

### B. Investigation (Fixed cost)

No.	Description	Quantity	Amount (INR)
1	Road and Bridge Inventory		
2	FWD Test and Pavement Evaluation		
3	Roughness Survey		
4	Axle Load Survey		
5	Material Survey and Investigation		
6	Sub-grade Investigation		
7	Traffic Survey		
8	Any other investigations/surveys		
9	*Sub-Soil Investigation (Boring)	Rate	Qty.
	a) Boring in all type of soils (other than hard rock)		1500m (for projects of length < 110 km) or 2000m (for projects of length > 110 km)
	b) Boring in hard rock		200m (for projects of length < 110 km) or 300m
			Amount (Rs)

			(for projects of length > 110 km)	
	<b>Total</b>			

Note: \* Quantities of borings shall be taken from Financial Proposal Form No. V. For financial evaluation, these quantities and rates quoted by the consultant will be considered. However, Payment shall be made on the actual quantity of boring at rates quoted above by the Consultant, which may be substantially more or less than the estimated quantities.

### C. Net Work Survey and GPR

No.	Description	Unit	Quantity	Rate ( INR )	Amount ( INR )
1	Net work Survey of the existing Highways as a repository for civil work as per directions from Authority.	Job	1		
2	GPR Survey for detection of under ground utilities	Job	1		
				Total	

### X. Cost of supply and fixing Boundary Pillars

Item	Amount (INR.)
Procuring and fixing boundary pillars and its installation, complete in all respect as per IRC:25,1967: Wherever the proposed alignment follows the existing alignment, the boundary pillars shall be fixed at an interval of 200m on either side of proposed Right of Way. Wherever there is a proposal of realignment of the existing Highway and/or construction of New Bypasses, Consultant shall fix boundary pillars along the proposed alignment on the extreme boundary on either side of the project Highway at 50 m interval. (lumpsum )	

### XI Land Acquisition Team including support staff and logistics/transportation

#### (A) Land acquisition Team including support staff:

S. No.	Position	Name	Number	Rate (INR)	Man Months	Amount (INR)
1	Ex-Land Revenue Inspector/Officer or	TBN	1		4	

	equivalent					
2	Ex-Kanoogo/Girdwar or equivalent	TBN	1		4	
3	Ex-Patwari or equivalent	TBN	1		4	
4	Typist	TBN	2		4	
5	Peon	TBN	1		4	
Total						
Number of Land acquisition Teams						
Grand Total for All Land acquisition Teams (A)						

(B) Logistics for Land acquisition Team:

S. No.	Item particulars	Number	Months	Rate (INR)	Amount (INR)
1	Computer including necessary peripherals	2	4		
2	Printers	2	4		
3	Vehicles (Bolero or equivalent) with monthly running limit of 4000 km	1	4		
Total					
Number of Land acquisition Teams					
Grand Total (B)					
Grand Total for All Land acquisition Teams and Logistics (A) + (B)					

**Note:** The Consultant shall provide one Land Acquisition Expert along with allied team and supporting logistic as envisaged in Clause 5.1.5.1 of TOR for each 100 km stretches proposed for DPR preparation or part thereof (For example total length of package is 343 km, there will be four team).



(Form-IV)

**Estimate of Costs for Expatriate Consultants (in Indian Rupees)**

I. Remuneration of Expatriate Staff including per diem allowances

No.	Positions	Name	Rate ( )	Staff Month	Amount ( )
			Total :		

**II. Mobilization and Demobilization**

1. International Airfares (Fixed costs)

Position	Round Trips	Rate	Amount
		Total	

2 Inland Travel in Home Country (Fixed Costs)

Lump Sum .....

3. Other Miscellaneous expenses (like DA, internal travel expenses other incidentals)  
(fixed cost)

Lump Sum .....

## TENTATIVE QUANTITIES FOR SUB-SOIL INVESTIGATIONS

(BORING) (Form -V)

S. No	Stretch Proposed for DPR	NH No.	Approximate Length (in Km.)	Package No.	State	Cumulative Tentative Quantities ( in m )	
						In Soils other than hard rock	In hard rock
1	<b>For projects of length &lt; 110 km</b> <Details of packages>	As per List at Annex-1	As per List at Annex-1	As per List at Annex-1	As per List at Annex-1	1500	200
2	<b>For projects of length &gt; 110 km</b> - <Details of packages>	As per List at Annex-1	As per List at Annex-1	As per List at Annex-1	As per List at Annex-1	2000	300

**DETAILED EVALUATION CRITERIA**

**1. First Stage Evaluation -Proof of Eligibility (Para 12.1 of Data Sheet)**

**1.1 Eligibility criteria for sole applicant firm.**

The sole applicant firm shall satisfy the following 3 (Three) Nos. of criteria.

(a) & (b) Firm should have experience of preparation of DPR/Feasibility of 4/6 lane of aggregate length as given below. The firm should have also prepared DPR/Feasibility of at least one project of 4/6 laning of minimum length as indicated below in the last 7 years (i.e. from 2010-11 onwards)

S. No.	Package No.	Tentative Length	Minimum Aggregate Length required	Minimum length of a Eligible Project (4/6 lane)	
			DPR/ Feasibility = Tentative Length	DPR	Feasibility
1	2	3	4	5	6
		13.500	13.500 Km	1000 Meter	1200 Meter

Note: Similar project means 2/4/6 lane as applicable for the project for which RFP is invited. For 2-lane projects experience of 4/6 lane also to be considered with a multiplication factor of 1.5. Experience of 4/6 lane shall be considered interchangeably for 4/6 laning projects. For 4/6 laning projects, experience of 2 lane will be considered with a multiplication factor of 0.4, but only for those 2 lane projects whose cost of consultancy services was more than Rs.1.0 crore

(c) Annual Average Turn Over for the last 5 years {In cases where, Audited/Certified copy of Balance Sheet for the FY 2016-17 is available, last five years shall be counted from 2012-13 to 2016-17. However, where audited/certified copy of the Balance Sheet for the FY 2016-17 is not available (as certified by the Statutory auditor) then in such cases last five years shall be considered from 2011-12 to 2015-16} of the firm from Consultancy services should be equal to more than Rs.5 crore.

**1.2 Eligibility criteria for Lead Partner/Other Partner in case of JV.**

In case of JV, the Lead Partner should fulfill at least 75% of all eligibility requirements and the other partner shall fulfill at least 50% of all eligibility requirements as given at 1.1 above. Thus a Firm applying as Lead Partner/Other Partner in case of JV/Associate should satisfy the following

(a) & (b) Firm should have experience of preparation of DPR/Feasibility of 4/6 lane of aggregate length as given below. The firm should have also prepared DPR/Feasibility of at least one project of 4/6 laning of minimum length as indicated below in the last 7 years (i.e. from 2008-09 onwards)

S. No.	Package No.	Minimum Aggregate Length required of DPR/ Feasibility km)		Minimum length of a Eligible Project (4/ 6 lane)			
		Lead in JV	Other Partner in JV	DPR		Feasibility	
				Lead in JV	Other Partner in JV	Lead in JV	Other Partner in JV

c ) **Minimum Annual Average Turn Over** for the last 5 years { In cases where, Audited/Certified copy of Balance Sheet for the FY 2016-17 is available, last five years shall be counted from 2012-13 to 2016-17. However, where audited/certified copy of the Balance Sheet for the FY 2016-17 is not available (as certified by the Statutory auditor) then in such cases last five years shall be considered from 2011-12 to 2015-16} of a firm applying as Lead Partner/Other Partner in case of JV from Consultancy services should be as given below:

No.	Mode of Submission by a firm	Annual Average Turn Over for the last 5 years
1	Lead Partner in a JV	Rs.3.75 crore
2	Other Lead partner in a JV	Rs.2.50 crore

**Note:** (i) Weightage to be given when experience by a Firm as Sole Firm/Lead Partner in a JV/Other Partner in a JV/As Associate

No.	Status of the firm in carrying out DPR/ Feasibility Study	Weightage for experience
1	Sole firm	100%
2	Lead partner in a JV	75%
3	Other partner in a JV	50 %
4	As Associate	25%

(ii) The experience of a firm in preparation of DPR for a private Concessionaire/contractor shall not be considered

## 2. Second Stage Evaluation -Technical Evaluation (Para 12.2 of Data Sheet)

For special projects such as special bridges, tunnels and expressways that require specialized capabilities and skill sets, the following is the break-up:

S. No.	Description	Maximum Points	Sub-Points
<b>1</b>	<b>Specific experience of the DPR consultancy related to the assignment for eligibility</b>	<b>14</b>	
<b>1.1</b>	<b>Aggregate Length of DPR / Feasibility study of 13.500 Km 2/4/6 Bridge/Flyover/ROB/viaduct/grade separator/any other major elevated structure</b>	<b>7</b>	
1.1.1	More than the indicative Length of the package applied for		4
1.1.2	More than 2 times the indicative length of the package applied for		6
1.1.3	More than 3 times the indicative length of the package applied for		7
<b>1.2</b>	<b>DPR for 2/4/6 Bridge/Flyover/ROB/viaduct/grade separator/any other major elevated structure projects each equal to 1 Km or more (or Feasibility Study for 2/4/6 Bridge/Flyover/ROB/viaduct/grade separator/any other major elevated structure projects each equal to or more than 8 Km)</b>	<b>7</b>	
1.2.1	1 project		4
1.2.2	2 projects		6
1.2.3	3 or more projects		7
<b>2</b>	<b>DPR of Bridge having length more than 500 m</b>	<b>3</b>	
2.1	1 bridge		1
2.2	2 bridges		2
2.3	3 or more bridges		3
<b>3</b>	<b>Specific experience of firms in terms of turnover</b>	<b>3</b>	
3.1	Firm's Average Turnover of last 5 years > 50 crore		3
3.2	Firm Average Turnover of last 5 years 20-50 crore		2.5
3.3	Firm Average Turnover of last 5 years 5 - 20 crore		2
<b>4</b>	<b>DPR for standalone Special bridges</b>		
<b>4.1</b>	<b>DPR of number of special bridges</b>	<b>5</b>	
4.1.1	1 project		1
4.1.2	2 projects		2

S. No.	Description	Maximum Points	Sub-Points
4.1.3	3 projects		3
4.1.4	4 projects		4
4.1.5	5 or more projects		5

Note:

A. In case feasibility study is a part of DPR services the experience shall be counted in DPR only. In case bridge is included as part of DPR of highway the experience will be (1) and (2)

B. Similar project means 2/4/6 lane as applicable for the project for which RFP is invited. For 2-lane projects experience of 4/6 lane also to be considered with a multiplication factor of 1.5. Experience of 4/6 lane shall be considered interchangeably for 4/6 laning projects. For 4/6 laning projects, experience of 2 lane will be considered with a multiplication factor of 0.4, but only for those 2 lane projects whose cost of consultancy services was more than Rs.1.0 crore

**Note:** (i) Weightage to be given when experience by a Firm as Sole Firm/Lead Partner in a JV/Other Partner in a JV/As Associate

No.	Status of the firm in carrying out DPR/ Feasibility Study	Weightage for experience
1	Sole firm	100 %
2	Lead partner in a JV	75%
3	Other partner in a JV	50 %
4	As Associate	25%

(ii) The experience of a firm in preparation of DPR for a private Concessionaire/contractor shall not be considered.

### B. Adequacy of approach and methodology (5)

S. No	Description	Points	
1	Site appreciation	1	

2	Team composition and task assignment	1	
3	Methodology	3	
<b>3.1</b>	<b>Approach and initial view on project plan including key challenges envisaged and potential solutions for</b>		
3.1.1	Proposed alignment and bypasses required and land acquisition requirements		1
3.1.2	Access control, rehabilitation of existing road, drainage and utilities		1
<b>3.2</b>	<b>Adoption of superior technology along with proof of past use vendor association</b>		1
	Total	5	

**C Material testing, survey and investigation, equipment and software proposed to be used (20)**

<b>S. No.</b>	<b>Description</b>	<b>Maximum Points</b>	<b>Sub-Points</b>
<b>1</b>	<b>Availability of in-house material testing facility</b>	<b>3</b>	
1.1	Available		3
1.2	Outsourced		
	(a) Through NABL accredited Labs / IIT / NIT labs		2
	(b) Other than (a)		1
<b>2</b>	<b>Field Investigation Facilities</b>	<b>2</b>	
2.1	Available (Created in-house at site)		2
2.2	Outsourced		
	(a) Through NABL accredited Labs / IIT / NIT labs		1
	(b) Other than (a)		0
<b>3</b>	<b>Office Equipment and Software</b>	<b>3</b>	
3.1	High Level (More than 75% as per ToR requirement)		3
3.2	Medium Level (Between 75%-50% as per ToR requirement)		2
3.3	Low Level (Less than 50% as per ToR requirement)		1
<b>4</b>	<b>Experience in LiDAR or better technology for topographic survey (Infrastructure sector)</b>	<b>5</b>	
4.1	1-2 projects		1
4.2	3-5 projects		2
4.3	6-10 projects		3
4.4	>10 projects		5
<b>5</b>	<b>Experience in using GPR and Induction Locator or better technologies for detection of sub-surface utilities (Infrastructure sector)</b>	<b>4</b>	
5.1	1-2 projects		1

S. No.	Description	Maximum Points	Sub-Points
5.2	3-5 projects		2
5.3	>5 projects		4
<b>6</b>	<b>Experience in digitization of cadastral maps for land surveys</b>	<b>3</b>	
6.1	Project of area upto 100 ha		1
6.2	Project of area between 100-500 ha		2
6.3	Project of area between 500 ha		3

**Note:** The experience of firm in LiDar or equivalent technology, GPR and Induction Locator or equivalent technologies and Experience in digitization of cadastral maps for land acquisition shall be supported by experience certificate. The experience of a firm in LiDar or equivalent technology, GPR and Induction Locator or equivalent technologies and Experience in digitization of cadastral maps for land acquisition for a private concessionaire/contractor shall be considered only if the experience certificate is authenticated by the concerned competent Government department/authority

#### 2.4. Qualification and Competence of the Key Staff for adequacy of the Assignment. (Para 12.2 of Data Sheet and Enclosure II of TOR)

##### 2.4.1 TEAM LEADER cum Senior Bridge Engineer

S. No.	Description	Max. Points
<b>I</b>	<b>General Qualification</b>	<b>25</b>
i)	Degree in Civil Engineering or equivalent [AICTE Approved]	20
ii)	Post Graduation in Highway Structures/ [AICTE Approved]	5
<b>II</b>	<b>Relevant Experience &amp; Adequacy for the Project</b>	<b>70</b>
<b>a)</b>	<b>Total Professional Experience</b>	<b>15</b>
	< <u>15</u> years	0
	<u>15-18</u> years	11
	<u>18-21</u> years	13
	> <u>21</u> years	15
<b>b)</b>	<b>Experience of 2/4 lane configuration bridges</b>	<b>25</b>
	<4 Projects	0
	4-6 Projects	20
	> 6 projects	25
<b>c)</b>	<b>Experience as Senior Bridge Engineer or Similar Capacity in Highway Design Consultancy Projects (2/4/6 laning or NH/SH/Expressways) involving design of Major Bridges ( minimum 2 nos of length more than 500m)</b>	<b>30</b>



	<2 numbers	0	
	2-4 numbers	24	
	5-6 numbers	27	
	> 6 numbers	30	
<b>III</b>	<b>Employment with Firm</b>		<b>5</b>
	Less than 1 Year	0	
	1-2 years	2.5	
	more than 2 years	5	
	<b>Total</b>		<b>100</b>

## 2.4.2 Senior HIGHWAY cum PAVEMENT ENGINEER

S. No.	Description	Max. Points
<b>I</b>	<b>General Qualification</b>	<b>25</b>
i)	Degree in Civil Engineering or equivalent [AICTE Approved]	20
ii)	Post graduation in Highway Engg/ Transportation Engineering[AICTE Approved]	5
<b>II</b>	<b>Relevant Experience &amp; Adequacy for the Project</b>	<b>70</b>
a)	<b>Total Professional Experience</b>	<b>15</b>
	<8years	0
	8-12 years	11
	12-15 years	13
	>15 years	15
(b)	<b>Experience in Highway Projects - Experience in Design/ Pavement Design of Highway Projects (2/4/6 laning of NH/SH/Expressways)</b>	<b>25</b>
	<6 years	0
	6-10 years	18
	10-15 years	22
	>15 years	25
c)	<b>Experience in Similar Capacity</b>	<b>30</b>
(i)	<b>In Design/ Pavement Design of Highway Projects (2/4/6 NH/SH/Expressways) in Similar Capacity (Minimum aggregate length 80 km)</b>	<b>20</b>
	<80km	0
	80km-150km	14
	150km-250km	17
	>250km	20
(ii)	<b>In Design/ Pavement Design of Highway Projects (2/4/6 laning of NH/SH/ Expressways) in Similar Capacity – Number of Projects</b>	<b>10</b>
	2 projects	8
	3- 5 projects	9
	More than 5 projects	10
<b>III</b>	<b>Employment with Firm</b>	<b>5</b>
	Less than 1 Year	0
	1-2 years	2.5
	more than 2 years	5

	<b>Total</b>		<b>100</b>
--	--------------	--	------------

### 2.4.3 BRIDGE ENGINEER

S. No.	Description		Max. Points
<b>I</b>	<b>General Qualification</b>		<b>25</b>
i)	Degree in Civil Engineering or equivalent[AICTE Approved]		20
ii)	Post Graduation in Structural Engineering/ Bridge Engineering[AICTE Approved]		5
<b>II</b>	<b>Relevant Experience &amp; Adequacy for the Project</b>		<b>70</b>
<b>a)</b>	<b>Total Professional Experience</b>		<b>15</b>
	<10 years	0	
	10-12years	11	
	12-15 years	13	
	>15 years	15	
<b>b)</b>	<b>Experience in Bridge Projects</b>		<b>25</b>
<b>(i)</b>	<b>Experience in project preparation and design of bridge projects</b>		<b>20</b>
	< 8 years	0	
	8-10 years	14	
	10-12 years	17	
	>12years	20	
<b>(ii)</b>	<b>Experience of 2/4 lane configuration bridges</b>		<b>5</b>
	<2 Projects	0	
	2-4 Projects	4	
	> 4 projects	5	
<b>c)</b>	<b>Experience as Senior Bridge Engineer or Similar Capacity in Highway Design Consultancy Projects (2/4/6 laning or NH/SH/Expressways) involving design of Major Bridges ( minimum 2 nos of length more than 200m)</b>		<b>30</b>
	<2 numbers	0	
	2-4 numbers	24	
	5-6 numbers	27	
	> 6 numbers	30	
<b>III</b>	<b>Employment with Firm</b>		<b>5</b>
	Less than 1 Year	0	
	1-2 years	2.5	
	more than 2 years	5	
	<b>Total</b>		<b>100</b>

#### 2.4.4 Traffic / Road Signage / Marking and Safety Expert

S. No.	Description		Max. Points
<b>I</b>	<b>General Qualification</b>		<b>25</b>
i)	Degree in Civil Engineering[AICTE Approved]		20
ii)	Post graduation in Traffic Engineering /Transportation Engineering / Transportation Planning[AICTE Approved]		5
<b>II</b>	<b>Relevant Experience &amp; Adequacy for the Project</b>		<b>70</b>
<b>a)</b>	<b>Total Professional Experience</b>		<b>15</b>
	<6 years	0	
	<u>6-10</u> years	11	
	<u>10-15</u> years	13	
	> <u>15</u> years	15	
<b>b)</b>	<b>Experience in Highway Projects – Experience on Similar Projects (2/4/6 laning of NH/SH/ Expressways)</b>		<b>25</b>
	<5years	0	
	<u>5-6</u> years	18	
	<u>6-10</u> years	22	
	> <u>10</u> years	25	
<b>c)</b>	<b>Experience as Traffic and Safety Expert / Traffic Engineer or in Similar Capacity in Highway Projects (2/4/6 laning of NH/SH/Expressways) (Minimum aggregate length 80 km)</b>		<b>30</b>
	<80km	0	
	80km-150km	24	
	150km -250km	27	
	>250km	30	
<b>III</b>	<b>Employment with Firm</b>		<b>5</b>
	Less than 1 Year	0	
	1-2 years	2.5	
	more than 2 years	5	
	<b>Total</b>		<b>100</b>

## 2.4.5 MATERIAL ENGINEER cum GEOTECHNICAL ENGINEER cum GEOLOGIST

S. No.	Description		Max. Points
<b>I</b>	<b>General Qualification</b>		<b>25</b>
i)	Degree in Civil Engineering /M. Sc. in Geology[AICTE Approved]		20
ii)	Post graduation in Foundation Engineering / Soil Mechanics / Geo Tech Engineering		5
<b>II</b>	<b>Relevant Experience &amp; Adequacy for the Project</b>		<b>70</b>
<b>a)</b>	<b>Total Professional Experience</b>		<b>15</b>
	<10 years	0	
	10-12 years	11	
	12-15 years	13	
	>15 years	15	
<b>b)</b>	<b>Experience in Highway Projects – In Similar Projects (2/4/6 laning of NH/SH/Expressways) in design and or Construction/ Construction Supervision</b>		<b>25</b>
	<7 years	0	
	7-10 years	18	
	10 -12 years	22	
	>12years	25	
<b>c)</b>	<b>Experience as Material cum Geo-technical Engineer or in Similar capacity on Highway Projects (2/4/6 laning of NH/SH/Expressways) (Minimum aggregate length 80 km)</b>		<b>30</b>
	<80km	0	
	80km-150km	24	
	150km – 250km	27	
	>250km	30	
<b>III</b>	<b>Employment with Firm</b>		<b>5</b>
	Less than 1 Year	0	
	1-2 years	2.5	
	more than 2 years	5	
	<b>Total</b>		<b>100</b>

### 1.4.6 SENIOR SURVEY ENGINEER

S. No.	Description		Max. Points
<b>I</b>	<b>General Qualification</b>		<b>25</b>
i)	Degree or equivalent in Civil Engineering / Diploma in Civil Engineering / Diploma in Surveying[AICTE Approved]		20
ii)	Post Graduation in Survey Engineering / Surveying / Remote Sensing [AICTE Approved]		5
<b>II</b>	<b>Relevant Experience &amp; Adequacy for the Project</b>		<b>70</b>
<b>a)</b>	<b>Total Professional Experience</b>		<b>15</b>
	<10 years	0	
	10-12 years	11	
	12-15 years	13	
	>15 years	15	
<b>b)</b>	<b>Experience in Highway Projects</b>		<b>25</b>
i)	<b>Experience in Similar Projects (2/4/6 laning of NH / SH / Expressways) in project preparation/ Construction / Construction Supervision</b>		20
	<8years	0	
	8 -10 years	14	
	10-12 years	17	
	>12 years	20	
ii)	<b>Knowledge and understanding of modern Computer based method of Surveying</b>		<b>5</b>
	<b>Yes</b>	5	
	<b>No</b>	0	
<b>c)</b>	<b>Experience as Survey Engineer or in Similar Capacity for project preparation of highway project (2/4/6 laning of NH/SH/Expressways) (Minimum Aggregate Length of to 80km)</b>		<b>30</b>
	<80km	0	
	80km-150km	24	
	150km-250km	27	
	>250km	30	
<b>III</b>	<b>Employment with Firm</b>		<b>5</b>
	Less than 1 Year	0	
	1-2 years	2.5	
	more than 2 years	5	
	<b>Total</b>		<b>100</b>

## 2.4.8 QUANTITY SURVEYOR/DOCUMENTATION EXPERT

S. No.	Description		Max. Points
<b>I</b>	<b>General Qualification</b>		<b>25</b>
i)	Graduation or equivalent in Civil Engineering / Certificate course from 'Institution of Quantity Surveying'[AICTE Approved]		20
ii)	Graduation or equivalent in Civil Engineering[AICTE Approved]		5
<b>II</b>	<b>Relevant Experience &amp; Adequacy for the Project</b>		<b>70</b>
a)	<b>Total Professional Experience</b>		<b>15</b>
	<10 years	0	
	10-12 years	11	
	12-15 years	13	
	>15 years	15	
b)	<b>Experience in Highway Projects- Experience in preparation of Bill of Quantities, Contract documents and documentation for major highway projects (2/4/6 laning of NH/SH/Expressways)</b>		<b>25</b>
	<8 years	0	
	8 -10 years	18	
	10-12 years	22	
	>12 years	25	
c)	<b>Experience as Quantity Surveyor / Documentation Expert or in Similar Capacity in Highway Projects (2/4/6 laning of NH/SH/Expressways) (Minimum Aggregate length of 80km)</b>		<b>30</b>
	<80km	0	
	80km-150km	24	
	150km – 250km	27	
	>250km	30	
<b>III</b>	<b>Employment with Firm</b>		<b>5</b>
	Less than 1 Year	0	
	1-2 years	2.5	
	more than 2 years	5	
	<b>Total</b>		<b>100</b>

## 2.4.9 LAND ACQUISITION EXPERT

S. No.	Description		Max. Points
<b>I</b>	<b>General Qualification</b>		<b>25</b>
i)	Graduation or equivalent		20
ii)	Post Graduation		5
<b>II</b>	<b>Relevant Experience &amp; Adequacy for the Project</b>		<b>70</b>
<b>a)</b>	<b>Total Professional Experience</b>		<b>15</b>
	<15 years	0	
	15-17 years	12	
	17-20 years	14	
	>20 years	15	
<b>b)</b>	<b>Experience in Land Acquisition works of Government/Authority</b>		<b>20</b>
	<10 years	0	
	10 -12 years	15	
	12-15 years	18	
	>15 years	20	
<b>c)</b>	<b>Experience in Land Acquisition works in Highway/road sector</b>		<b>25</b>
	Nil project	0	
	1 project	18	
	2 projects	22	
	3 projects	25	
<b>d)</b>	<b>Retired Revenue officer at the level of ADM/SDM / Tehsildar</b>		<b>10</b>
<b>III</b>	<b>Employment with Firm</b>		<b>5</b>
	Less than 1 Year	0	
	1-2 years	2.5	
	more than 2 years	5	
	<b>Total</b>		<b>100</b>





## **Assumptions to be made regarding Similar Capacity for various positions**

### **1. Team Leader cum Senior Bridge Engineer**

- i) On behalf of Consultant / Contractor: Team Leader/Senior Bridge Engineer.
- ii) In Government Organizations: Superintending Engineer (or equivalent) and above

### **2. Bridge Engineer**

- i) On behalf of Consultant: Senior Bridge Engineer/Bridge Engineer/ Bridge Design Engineer
- ii) In Government Organizations: Executive Engineer (or equivalent) and above

### **3. Senior Highway cum Pavement Engineer**

- i) On behalf of Consultant: Highway Engineer/Highway Design Engineer/Pavement Engineer.
- ii) In Government Organizations: Executive Engineer (or equivalent) and above

### **4. Material Engineer cum Geo Technical Engineer- Geologist**

- i) On behalf of Consultant: Material Engineer/Material Expert/Geo Technical Engineer
- ii) In Government Organizations: Executive Engineer (or equivalent) and above
- iii) On behalf of Contractor: Material Engineer/Material Expert/Geo Technical Engineer/Manager (Material)

## **5. Traffic and Safety Expert**

- i) On behalf of Consultant: Traffic Engineer/Transportation Engineer/Road Safety Expert
- ii) In Government Organizations: Executive Engineer (or equivalent) and above
- iii) On behalf of Contractor: Traffic Engineer/Transportation Engineer/ Road Safety Expert

## **6. Senior Survey Engineer**

- i) On behalf of Consultant: Senior Survey Engineer/ Survey Engineer/ Senior Surveyor
- ii) In Government Organizations: Surveyor/Engineer (or equivalent)
- iii) On behalf of Contractor: Senior Survey Engineer/Survey Engineer/ Senior Surveyor

## **7. Environmental Specialist**

- i) On behalf of Consultant /Contractor: Environmental Engineer/ Environmental Specialist/ Environmental Expert
- ii) In Government Organization: Officers who has dealt environment/forest matter.

## **8. Quantity Surveyor/Documentation Expert**

- i) On behalf of Consultant /Contractor: Quantity Surveyor
- (ii) In Government Organizations: Assistant Engineer (or equivalent)

## **9. Land Acquisition Expert**

- i) On behalf of Consultant /Contractor: Land Acquisition Expert
- (ii) In Government Organizations: ADM, SDM, Tehsildar,

## **10. UTILITY Expert**

- i) On behalf of Consultant /Contractor: Utility Expert
- (ii) In Government Organizations: Executive Engineer (or equivalent) and above .

Consultant has to assess the major utility shifting involved and propose the CV accordingly.

Note: While carrying out evaluation of key personnel, the experience in similar capacity is also a criteria of evaluation and assumptions to be made regarding similar capacity have been mentioned above. However, if a key personnel has worked in next lower category to the similar capacity, the marks allotted to key personnel in the category 'experience in similar capacity' shall be reduced to two thirds of marks in this category. This shall be applicable for evaluation of all key personnel.

**DRAFT CONTRACT AGREEMENT**

Between

National Highways Authority of India  
(Ministry of Road Transport and Highways)  
Dwarka, New Delhi-75

And

M/s ..... in JV with M/s ..... And in  
Association with M/s .....

For

**Consultancy Services for Preparation of Feasibility Study and  
Detailed Project Report for:-**

- (i) 4-lane Elevated Section at Begusarai at Chainage 221.910 to 224.935 on NH-31, Length 3.025 Km
- (ii) 4-lane Elevated section of Shivala - Bihta section of Patna - Koilwar on NH-30 at design Chainage 16.050 to 29.500 of proposed alignment of NH-30, Length 13.450 Km
- (iii) 4-lane Elevated section at Gopalganj Chainage 384.483 to 386.362 on NH-28, Length 1.879 Km

(From km \_\_\_\_\_ to km \_\_\_\_\_ of NH in the State of ... )

## CONTENTS

Sl. No.	Description	Page No. I.
	CONTRACT FORCONSULTANT’S SERVICES	
II	GENERAL CONDITIONS OF CONTRACT	
1.	<b>General Provisions</b>	
1.1	Definitions	
1.2	Relation between the Parties	
1.3	Law Governing the Contract	
1.4	Language	
1.5	Headings	
1.6	Notices	
1.7	Location	
1.8	Authority of Member in Charge	
1.9	Authorized Representatives	
1.10	Taxes and Duties	
2.	<b>Commencement, Completion, Modification and Termination of Contract</b>	
2.1	Effectiveness of Contract	
2.2	Termination of Contract for Failure to Become Effective	
2.3	Commencement of Services	
2.4	Expiration of Contract	
2.5	Entire Agreement	
2.6	Modification	
2.7	Force Majeure	
2.7.1	Definition	
2.7.2	No Breach of Contract	
2.7.3	Measures to be Taken	
2.7.4	Extension of Time	
2.7.5	Payments	
2.7.6	Consultation	
2.8	Suspension	
2.9	Termination	
2.9.1	By the Client	
2.9.2	By the Consultants	

- 2.9.3 Cessation of Rights and Obligations
- 2.9.4 Cessation of Services
- 2.9.5 Payment upon Termination
- 2.9.6 Disputes about Events of Termination

### **3. Obligations of the Consultants**

- 3.1 General
  - 3.1.1 Standard of Performance
  - 3.1.2 Law Governing Services
- 3.2 Conflict of Interests
  - 3.2.1 Consultants not to Benefit from Commissions, discounts etc.
  - 3.2.2 Consultants and Affiliates not to be otherwise interested in Project
  - 3.2.3 Prohibition of Conflicting Activities
- 3.3 Confidentiality
- 3.4 Liability of the Consultants
- 3.5 Insurance to be taken out by the Consultants
- 3.6 Accounting, Inspection and Auditing
- 3.7 Consultants' Actions requiring Client's prior Approval
- 3.8 Reporting Obligations
- 3.9 Documents prepared by the Consultants to be the Property of the Client
- 3.10 Equipment and Materials furnished by the Client

### **4. Consultants' Personnel**

- 4.1 General
- 4.2 Description of Personnel
- 4.3 Approval of Personnel
- 4.4 Working Hours, Overtime, Leave etc.
- 4.5 Removal and/or Replacement of Personnel
- 4.6 Resident Project Manager

### **5. Obligations of the Client**

- 5.1 Assistance and Exemptions
- 5.2 Access to Land
- 5.3 Change in the Applicable Law
- 5.4 Services, Facilities and Property of the Client
- 5.5 Payment

### **6. Payment to the Consultants**

- 6.1 Cost Estimates; Ceiling Amount
- 6.2 Currency of Payment
- 6.3 Mode of Billing and Payment

### **7. Responsibility for accuracy of the project document**

- 7.1 General
- 7.2 Retention money
- 7.3 Penalty
- 7.4 Action for deficiency in services

### **8. Fairness and Good Faith**

- 8.1 Good Faith

8.2                    Operation of the Contract

**9.                    SETTLEMENT OF DISPUTES**

9.1                    Amicable Settlement

9.2                    Dispute Settlement



### **III. SPECIAL CONDITIONS OF CONTRACT**

#### **IV. APPENDICES**

- Appendix A: Terms of reference containing, inter-alia, the Description of the Services and Reporting Requirements
- Appendix B: Consultants' Sub consultants, Key Personnel and Sub Professional Personnel, Task assignment, work programme, manning schedule, qualification requirements of key personnel, schedule for submission of various report.
- Appendix C: Hours of work for Consultants' Personnel
- Appendix D: Duties of the Client
- Appendix E: Cost Estimate
- Appendix F: Copy of letter of invitation
- Appendix G: Copy of letter of acceptance
- Appendix H(1): Format for Bank Guarantee for Performance Security for individual work
- Appendix H(2): Format for Bank Guarantee for Performance Security for a number of works
- Appendix I: Minutes of the Pre-bid meeting

## DRAFT CONTRACT FOR CONSULTANT'S SERVICES

## CONTRACT FOR CONSULTANTS' SERVICES

### Consultancy Services for Preparation of Feasibility Study and Detailed Project Report for:-

- (i) 4-lane Elevated Section at Begusarai at Chainage 221.910 to 224.935 on NH-31, Length 3.025 Km
- (ii) 4-lane Elevated section of Shivala - Bihta section of Patna - Koilwar on NH-30 at design Chainage 16.050 to 29.500 of proposed alignment of NH-30, Length 13.450 Km
- (iii) 4-lane Elevated section at Gopalganj Chainage 384.483 to 386.362 on NH-28, Length 1.879 Km

(From km \_\_\_\_\_ to km \_\_\_\_\_ Of NH in the State of ....)

This CONTRACT (hereinafter called the "Contract") is made on the ----- day of the month of -----2015 , between, on the one hand, National Highways Authority of India (NHAI), New Delhi (hereinafter called the "Client") and, on the other hand, M/s ----- in JV with ----- and in Association with ----- (hereinafter called the "Consultants").

#### WHEREAS

- (A) the Client has requested the Consultants to provide certain consulting services as defined in the General Conditions attached to this Contract (hereinafter called the "Services");
- (B) the Consultants, having represented to the Client that they have the required professional skills, personnel and technical resources, have agreed to provide the Services on the terms and conditions set forth in this Contract;

NOW THEREFORE the parties hereto hereby agree as follows:

1 The following documents attached hereto shall be deemed to form an integral part of this Contract:

- (a) The General Conditions of Contract (hereinafter called "GC");
- (b) The Special Conditions of contract (hereinafter called "SC");
- (c) The following Appendices:

Appendix A: Terms of reference containing, inter-alia, the Description of the Services and Reporting Requirements

Appendix B: Consultants' Sub consultants, Key Personnel and Sub Professional Personnel, Task assignment, work programme, manning schedule, qualification requirements of key personnel, and schedule for submission of various report.

Appendix C: Hours of work for Consultants' Personnel

Appendix D: Duties of the Client

Appendix E: Cost Estimate

Appendix F: Copy of letter of invitation

Appendix G: Copy of letter of acceptance

Appendix H: Copy of Bank Guarantee for Performance Security

Appendix-I: Minutes of the pre-bid meeting

2. The mutual rights and obligations of the Client and the Consultants shall be as set forth in the Contract; in particular:
  - (a) The Consultants shall carry out the Services in accordance with the provisions of the Contract; and
  - (b) Client shall make payments to the Consultants in accordance with the provisions of the Contract.

IN WITNESS WHEREOF, the Parties hereto have caused this Contract to be signed in their respective names as of the day and year first above written.

FOR AND ON BEHALF OF  
(National Highways Authority of India)

Witness

By  
Authorized Representative

1. Signature Name  
Address
2. Signature Name  
Address

FOR AND ON BEHALF OF  
(Consultant)

Witness

By  
Authorized Representative

1. Signature  
Name  
Address
2. Signature Name  
Address



## GENERAL CONDITIONS OF CONTRACT

# GENERAL CONDITIONS OF CONTRACT

## 1. GENERAL PROVISIONS

### 1.1 Definitions

Unless the context otherwise requires, the following terms whenever used in this Contract have the following meanings:

- (a) “Applicable Law means the laws and any other instruments having the force of law in the Government’s country as they may be issued and in force from time to time;
- (b) “Contract” means the Contract signed by the Parties, to which these General Conditions of Contract are attached, together with all the documents listed in Clause 1 of such signed Contract;
- (c) “Effective Date” means the date on which this Contract comes into force and effect pursuant to Clause GC 2.1;
- (d) “foreign currency” means any currency other than the currency of the Government;
- (e) “GC” means these General Conditions of Contract;
- (f) “Government” means the Government of India;
- (g) “local currency” means the currency of the Government;
- (h) “Member”, in case the Consultants consist of a joint venture or consortium of more than one entity, means any of these entities, and “Members” means all of these entities;
- (i) “Personnel” means persons hired by the Consultants or by any Sub consultant as employees and assigned to the performance of the Services or any part thereof; “foreign Personnel” means such persons who at the time of being so hired had their domicile outside India; and “local Personnel” means such persons who at the time of being so hired had their domicile inside India;
- (j) “Party” means the Client or the Consultants, as the case may be, and Parties means both of them;
- (k) “Services” means the work to be performed by the Consultants pursuant to this Contract for the purposes of the Project, as described in Appendix A hereto;
- (l) “SC” means the Special Conditions of Contract by which these General Conditions of Contract may be amended or supplemented;

- (m) “Sub consultant” means any entity to which the Consultants subcontract any part of the Services in accordance with the provisions of Clause GC 3.7; and
- (n) “Third Party” means any person or entity other than the Government, the Client, the Consultants or a Sub consultant.

## **1.2 Relation between the Parties**

Nothing contained herein shall be construed as establishing a relation of master and servant or of agent and principal as between the Client and the Consultants. The Consultants, subject to this Contract, have complete charge of Personnel performing the Services and shall be fully responsible for the Services performed by them or on their behalf hereunder.

## **1.3 Governing Law and Jurisdiction**

This Contract, its meaning and interpretation, and the relation between the Parties shall be governed by the Applicable Laws of India and the Courts at .....shall have exclusive jurisdiction over matters arising out of or relating to this Agreement.

## **1.4 Language**

This Contract has been executed in the language specified in the SC, which shall be the binding and controlling language for all matters relating to the meaning or interpretation of this Contract.

## **1.5 Table of Contents and Headings**

The table of contents, headings or sub-headings in this agreement are for convenience for reference only and shall not be used in, and shall not limit, alter or affect the construction and interpretation of this Contract.

## **1.6 Notices**

*1.6.1 Any notice, request or consent required or permitted to be given or made pursuant to this Contract shall be in writing. Any such notice, request or consent shall be deemed to have been given or made when delivered in person to an authorized representative of the Party to whom the communication is addressed, or when sent by registered mail, facsimile or e-mail to such Party at the address specified in the SC.*

1.6.2 Notice will be deemed to be effective as specified in the SC.

1.6.3 A party may change its address for notice hereunder by giving the other Party notice of such change pursuant to the provisions listed in the SC with respect to Clause GC 1.6.2.

## **1.7 Location**

The Services shall be performed at such locations as are specified in **Letter of Acceptance (Appendix-I)** hereto and, where the location of a particular task is not so specified, at such locations, whether in India or elsewhere, as the Client may approve.

## **1.8 Authority of Member in Charge**

In case the Consultants consist of a joint venture of more than one entity, with or without an Associate the Members hereby authorize the entity specified in the SC to



act on their behalf in exercising all the Consultants' rights and obligations towards the Client under this Contract, including without limitation the receiving of instructions and payments from the Client.

#### **1.9 Authorized Representatives**

Any action required or permitted to be taken, and any document required or permitted to be executed, under this Contract by the Client or the Consultants may be taken or executed by the officials specified in the SC.

#### **1.10 Taxes and Duties**

Unless otherwise specified in the SC, the Consultants shall pay all such taxes, duties, fees and other impositions as may be levied under the Applicable Law.

### **2. COMMENCEMENT, COMPLETION, MODIFICATION AND TERMINATION OF CONTRACT**

#### **2.1 Effectiveness of Contract**

This Contract shall come into force and effect on the date of the Client's notice to the Consultants instructing the Consultants to begin carrying out the Services. This notice shall confirm that the effectiveness conditions, if any, listed in the SC have been met.

#### **2.2 Termination of Contract for Failure to Become Effective**

If this Contract has not become effective within such time period after the date of the Contract signed by the Parties as shall be specified in the SC, either Party may, by not less than four (4) weeks' written notice to the other Party, declare this Contract to be null and void, and in the event of such a declaration by either Party, neither Party shall have any claim against the other Party with respect hereto.

#### **2.3 Commencement of Services**

The Consultants shall begin carrying out the Services at the end of such time period after the Effective Date as shall be specified in the SC.

#### **2.4 Expiration of Contract**

Unless terminated earlier pursuant to Clause GC 2.9 hereof, this Contract shall expire when services have been completed and all payments have been made at the end of such time period after the Effective Date as shall be specified in the SC.

#### **2.5 Entire Agreement**

This Contract contains all covenants, stipulations and provisions agreed by the Parties. No agent or representative of either Party has authority to make, and the Parties shall not be bound by or be liable for, any statement, representation, promise or agreement not set forth herein.

#### **2.6 Modification**

Modification of the terms and conditions of this Contract, including any modification of the scope of the Services, may only be made by written agreement between the Parties. Pursuant to Clause GC 8.2 hereof, however, each party shall give due consideration to any proposals for modification made by the other Party.

## **2.7 Force Majeure**

### **2.7.1 Definition**

- (a) For the purposes of this Contract, “Force Majeure” means an event which is beyond the reasonable control of a Party, and which makes a Party’s performance of its obligations hereunder impossible or so impractical as reasonably to be considered impossible in the circumstances, and includes, but is not limited to, war, riots, civil disorder, earthquake, fire, explosion, storm, flood or other adverse weather conditions, strikes, lockouts or other industrial action (except where such strikes, lockouts or other industrial action are within the power of the Party invoking Force Majeure to prevent), confiscation or any other action by government agencies.
- (b) Force Majeure shall not include (i) any event which is caused by the negligence or intentional action of a Party or such Party’s Sub consultants or agents or employees, nor (ii) any event which a diligent Party could reasonably have been expected to both (A) take into account at the time of the conclusion of this Contract and (B) avoid or overcome in the carrying out of its obligations hereunder.
- (c) Force Majeure shall not include insufficiency of funds or failure to make any payment required hereunder.

### **2.7.2 No Breach of Contract**

The failure of a Party to fulfill any of its obligations hereunder shall not be considered to be a breach of, or default under, this Contract insofar as such inability arises from an event of Force Majeure, provided that the Party affected by such an event has taken all reasonable precautions, due care and reasonable alternative measures, all with the objective of carrying out the terms and conditions of this Contract.

### **2.7.3 Measures to be Taken**

- (a) A party affected by an event of Force Majeure shall take all reasonable measures to remove such Party’s inability to fulfill its obligations hereunder with a minimum of delay.
- (b) A party affected by an event of Force Majeure shall notify the other Party of such event as soon as possible, and in any event not later than fourteen (14) days following the occurrence of such event, providing evidence of the nature and cause of such event, and shall similarly give notice of the restoration of normal conditions as soon as possible.
- (c) The Parties shall take all reasonable measures to minimize the consequences of any event of Force Majeure.

### **2.7.4 Extension of Time**

Any period within which a Party shall, pursuant to this Contract, complete any action or task, shall be extended for a period equal to the time during which such Party was unable to perform such action as a result of Force Majeure.

### **2.7.5 Payments**

During the period of their inability to perform the Services as a result of an event of Force Majeure, the Consultants shall be entitled to be reimbursed for additional costs

reasonably and necessarily incurred by them during such period for the purposes of the Services and in reactivating the Services after the end of such period.

#### **2.7.6 Consultation**

Not later than thirty (30) days after the Consultants, as the result of an event of Force Majeure, have become unable to perform a material portion of the Services, the Parties shall consult with each other with a view to agreeing on appropriate measures to be taken in the circumstances.

#### **2.8 Suspension**

The Client may, by written notice of suspension to the Consultants, suspend all payments to the Consultants hereunder if the Consultants fail to perform any of their obligations under this Contract, including the carrying out of the Services, provided that such notice of suspension (i) shall specify the nature of the failure, and (ii) shall request the Consultants to remedy such failure within a period not exceeding thirty (30) days after receipt by the Consultants of such notice of suspension.

#### **2.9 Termination**

##### **2.9.1 By the Client**

The Client may, by not less than thirty (30) days' written notice of termination to the Consultants (except in the event listed in paragraph (f) below, for which there shall be a written notice of not less than sixty (60) days), such notice to be given after the occurrence of any of the events specified in paragraphs (a) through (f) of this Clause 2.9.1, terminate this Contract:

- (a) if the Consultants fail to remedy a failure in the performance of their obligations are under, as specified in a notice of suspension pursuant to Clause 2.8 hereinabove, within thirty (30) days of receipt of such notice of suspension or within such further period as the Client may have subsequently approved in writing;
- (b) if the Consultants become (or, if the Consultants consist of more than one entity, if any of their Members becomes) insolvent or bankrupt or enter into any agreements with their creditors for relief of debt or take advantage of any law for the benefit of debtors or go into liquidation or receivership whether compulsory or voluntary;
- (c) if the Consultants fail to comply with any final decision reached as a result of arbitration proceedings pursuant to Clause 8 hereof;
- (d) if the Consultants submit to the Client a statement which has a material effect on the rights, obligations or interests of the Client and which the Consultants know to be false;
- (e) if, as the result of Force Majeure, the Consultants are unable to perform a material portion of the Services for a period of not less than sixty (60) days; or
- (f) if the Client, in its sole discretion and for any reason whatsoever, decides to terminate this Contract.

### **2.9.2 By the Consultants**

The Consultants may, by not less than thirty (30) day's written notice to the Client, such notice to be given after the occurrence of any of the events specified in paragraphs (a) through (d) of this Clause 2.9.2, terminate this Contract:

- (a) if the Client fails to pay any money due to the Consultants pursuant to this contract and not subject to dispute pursuant to Clause 8 hereof within forty-five(45) days after receiving written notice from the Consultants that such payment is overdue;
- (b) if the Client is in material breach of its obligations pursuant to this Contract and has not remedied the same within forty-five (45) days (or such longer period as the Consultants may have subsequently approved in writing) following the receipt by the Client of the Consultants' notice specifying such breach;
- (c) if, as the result of Force Majeure, the Consultant are unable to perform a material portion of the Services for a period of not less than sixty (60) days; or
- (d) if the Client fails to comply with any final decision reached as a result of arbitration pursuant to Clause 8 hereof.

### **2.9.3 Cessation of Rights and Obligations**

Upon termination of this Contract pursuant to Clauses 2.2 or 2.9 hereof, or upon expiration of this Contract pursuant to Clause 2.4 hereof, all rights and obligations of the Parties hereunder shall cease, except (i) such rights and obligations as may have accrued on the date of termination or expiration, (ii) the obligation of confidentiality set forth in Clause 3.3 hereof, (iii) the Consultant's obligation to permit inspection, copying and auditing of their accounts and records set forth in Clause 3.6 (ii) hereof, and (iv) any right which a Party may have under the Applicable Law.

### **2.9.4 Cessation of Services**

Upon termination of this Contract by notice of either Party to the other pursuant to Clauses 2.9.1 or 2.9.2 hereof, the Consultants shall, immediately upon dispatch or receipt of such notice, take all necessary steps to bring the Services to a close in a prompt and orderly manner and shall make every reasonable effort to keep expenditures for this purpose to a minimum. With respect to documents prepared by the Consultants and equipment and materials furnished by the Client, the Consultants shall proceed as provided, respectively, by Clauses 3.9 or 3.10 hereof.

### **2.9.5 Payment upon Termination**

Upon termination of this Contract pursuant to Clauses 2.9.1 or 2.9.2 hereof, the Client shall make the following payments to the Consultants (after offsetting against these payments any amount that may be due from the Consultant to the Client):

- (i) remuneration pursuant to Clause 6 hereof for Services satisfactorily performed prior to the effective date of termination.
- (ii) reimbursable expenditures pursuant to Clause 6 hereof for expenditures actually incurred prior to the effective date of termination; and
- (iii) except in the case of termination pursuant to paragraphs (a) through (d) of Clause 2.9.1 hereof, reimbursement of any reasonable cost incident to the prompt and orderly termination of the Contract including the cost of the return travel of the Consultants' personnel and their eligible dependents.

### **2.9.6 Disputes about Events of Termination**

If either Party disputes whether an event specified in paragraphs (a) through (e) of Clause 2.9.1 or in Clause 2.9.2 hereof has occurred, such Party may, within forty-five (45) days after receipt of notice of termination from the other Party, refer the matter to arbitration pursuant to Clause 8 hereof, and this Contract shall not be terminated on account of such event except in accordance with the terms of any resulting arbitral award.

## **3. OBLIGATIONS OF THE CONSULTANTS**

### **3.1 General**

#### **3.1.1 Standard of Performance**

The Consultants shall perform the Services and carry out their obligations here under with all due diligence, efficiency and economy, in accordance with generally accepted professional techniques and practices, and shall observe sound management practices, and employ appropriate advanced technology and safe and effective equipment, machinery, materials and methods. The Consultants shall always act, in respect of any matter relating to this Contract or to the Services, as faithful advisers to the Client, and shall at all times support and safeguard the Client's legitimate interests in any dealings with Sub consultants or Third Parties.

#### **3.1.2 Law Governing Services**

The Consultants shall perform the Services in accordance with the Applicable Law and shall take all practicable steps to ensure that any Sub consultants, as well as the Personnel and agents of the Consultants and any Sub consultants, comply with the Applicable Law. The Client shall advise the Consultants in writing of relevant local customs and the Consultants shall, after such notifications, respect such customs.

### **3.2 Conflict of Interests**

#### **3.2.1 Consultants not to Benefit from Commissions, Discounts, etc.**

The remuneration of the Consultants pursuant to Clause 6 hereof shall constitute the Consultants' sole remuneration in connection with this Contract or the Services and the Consultants shall not accept for their own benefit any trade commission, discount or similar payment in connection with activities pursuant to this Contract or to the Services or in the Discharge of their obligations hereunder, and the Consultants shall use their best efforts to ensure that any Sub consultants, as well as the Personnel and agents of either of them, similarly shall not receive any such additional remuneration.

#### **3.2.2 Consultants and Affiliates not to be otherwise interested in Project**

The Consultants agree that, during the term of this Contract and after its termination, the Consultants and any entity affiliated with the Consultants, as well as any Sub consultant and any entity affiliated with such Sub consultant, shall be disqualified from providing goods, works or services (other than the Services and any continuation thereof) for any project resulting from or closely related to the Services.

#### **3.2.3 Prohibition of Conflicting Activities**

Neither the Consultants nor their Sub consultants nor the Personnel of either of them shall engage, either directly or indirectly, in any of the following activities:

(a) during the term of this Contract, any business or professional activities in the Government's country which would conflict with the activities assigned to them under this Contract; or

(b) after the termination of this Contract, such other activities as may be specified in the SC.

### **3.3 Confidentiality**

The Consultants, their Sub consultants and the Personnel of either of them shall not, either during the term or within two (2) years after the expiration of this Contract, disclose any proprietary or confidential information relation to the Project, the Services, this Contract or the Client's business or operations without the prior written consent of the Client.

### **3.4 Liability of the Consultants**

Subject to additional provisions, if any, set forth in the SC, the Consultants' liability under this Contract shall be as provided by the Applicable Law.

### **3.5 Insurance to be taken out by the Consultants**

The Consultants (i) shall take out and maintain, and shall cause any Sub consultants to take out and maintain, at their (or the Sub consultants', as the case may be) own cost but on terms and conditions approved by the Client, insurance against the risks, and for the coverage, as shall be specified in the Special Conditions (SC), and (ii) at the Client's request, shall provide evidence to the Client showing that such insurance has been taken out and maintained and that the current premiums therefore have been paid.

### **3.6 Accounting, Inspection and Auditing**

The Consultants (i) shall keep accurate and systematic accounts and records in respect of the Services hereunder, in accordance with internationally accepted accounting principles and in such form and detail as will clearly identify all relevant time charges and cost, and the bases thereof (including the bases of the Consultants' costs and charges), and (ii) shall permit the Client or its designated representative periodically, and up to one year from the expiration or termination of this Contact, to inspect the same and make copies thereof as well as to have them audited by auditors appointed by the Client.

### **3.7 Consultants' Actions requiring Client's prior Approval**

The Consultants shall obtain the Client's prior approval in writing before taking any of the following actions:

- (a) appointing such members of the Personnel as are listed in Appendix B;
- (b) entering into a subcontract for the performance of any part of the Services, it being understood (i) that the selection of the Sub-consultant and the terms and conditions of the subcontract shall have been approved in writing by the Client prior to the execution of the subcontract, and (ii) that the Consultants shall remain fully liable for the performance of the Services by the Sub-consultant and its Personnel pursuant to this Contract;
- (c) any other action that may be specified in the SC.

### **3.8 Reporting Obligations**

The Consultants shall submit to the Client the reports and documents specified in **Appendix A/E** here to, in the form, in the numbers and within the time periods set forth in the said Appendix. Reporting stages, review progress and checklist shall be as

reflected in the DPR.

### **3.9 Documents prepared by the Consultants to be the Property of the Client**

All plans, drawings, specifications, designs, reports and other documents prepared by the Consultants in performing the Services shall become and remain the property of the Client, and the Consultants shall, not later than upon termination or expiration of this Contract, deliver all such documents to the Client, together with a detailed inventory thereof. The Consultants may retain a copy of such documents. Restrictions about the future use of these documents, shall be as specified in the SC.

### **3.10 Equipment and Materials furnished by the Client**

Equipment and materials made available to the Consultants by the Client, or purchased by the Consultants with funds provided by the Client, shall be the property of the Client and shall be marked accordingly. Upon termination or expiration of this Contract, the Consultants shall make available to the Client an inventory of such equipment and materials and shall dispose of such equipment and materials in accordance with the Client's instructions. While in possession of such equipment and materials, the Consultants, unless otherwise instructed by the Client in writing, shall insure them in an amount equal to their full replacement value.

## **4. CONSULTANTS' PERSONNEL**

### **4.1 General**

The Consultants shall employ and provide such qualified and experienced Personnel as are required to carry out the Services.

### **4.2 Description of Personnel**

(a) The titles, agreed job descriptions, minimum qualification and estimated periods of engagement in the carrying out of the Services of each of the Consultants' Key Professional / Sub Professional Personnel are described in Appendix B.

(b) If required to comply with the provisions of Clause 3.1.1 of this Contract, adjustments with respect to the estimated periods of engagement of Key Professional / Sub Professional Personnel set forth in Appendix B may be made by the Consultants by written notice to the Client, provided

(i) that such adjustments shall not alter the originally estimated period of engagement of any individual by more than 10% or one week, whichever is larger, and

(ii) that the aggregate of such adjustments shall not cause payments under this Contract to exceed the ceilings set forth in Clause 6.1 (b) of this Contract. Any other such adjustments shall only be made with the Client's written approval.

(c) If additional work is required beyond the scope of the Services specified in Appendix A, the estimated periods of engagement of Key Personnel set forth in Appendix B may be increased by agreement in writing between the Client and the Consultants.

### **4.3 Approval of Personnel**

The Key Personnel and Sub consultants listed by title as well as by name in Appendix B are hereby approved by the Client. In respect of other Key Personnel which the Consultants propose to use in the carrying out of the Services, the Consultants shall submit to the Client for review and approval a copy of their biographical data. If the Client does not object in writing (stating the reasons for the objection) within twenty-



one (21) calendar days from the date of receipt of such biographical data, such Key Personnel shall be deemed to have been approved by the Client.

#### **4.4 Working Hours, Overtime, Leave, etc.**

(a) Working hours and holidays for Key Professional / Sub Professional Personnel are set forth in Appendix C hereto. To account for travel time, foreign Personnel carrying out Services inside the Government's country shall be deemed to have commenced (or finished) work in respect of the Services such number of days before their arrival in (or after their departure from) the Government's country is specified in Appendix C hereto.

(b) The Key Professional / Sub Professional Personnel shall not be entitled to be paid for overtime nor to take paid sick leave or vacation leave except as specified in Appendix C hereto, and except as specified in such Appendix, the Consultants' remuneration shall be deemed to cover these items. All leave to be allowed to the Personnel is included in the staff- months of service set for in Appendix B. Any taking of leave by Personnel shall be subject to the prior approval of the Client by the Consultants, who shall ensure that absence for leave purposes will not delay the progress and adequate supervision of the Services.

#### **4.5 Removal and/or Replacement of Personnel**

Removal and/or replacement of Personnel shall be regulated as under:

**4.5.1** In case notice to commence services pursuant to Clause 2.1 of this Contract is not ordered by Client within 120 days of signing of contract the key personnel can excuse themselves on valid grounds, e.g., selection on some other assignment, health problem developed after signing of contract, etc. In such a case no penalty shall be levied on the Firm or on the person concerned. The firm shall however be asked to give a replacement by an equal or better scoring person, whenever mobilization is ordered.

**4.5.2** In case notice to commence services is given within 120 days of signing of contract the replacement shall be as below:

a. Replacement up to 33%: Replacement shall be by an equal or better scoring person. Reduction in remunerations for the balance period shall be @ 5% of the monthly rate.

b. Replacement of more than 33% and up to 50%: Replacement shall be by an equal or better scoring person. Reduction in remunerations for the balance period shall be @ 10% of the monthly rate.

c. Replacement beyond 50% and upto 66%. Replacement shall be by an equal or better scoring person. Reduction in remunerations for the balance period shall be @ 15% of the monthly rate.

d. Replacement beyond 66 % shall normally not be considered. However in exceptional circumstances, where it becomes absolutely essential the remunerations of the substitute shall be reduced by 50 % of the original person replaced. Replacement shall be by an equal or better scoring person, The Department may initiate action for termination/debarment of such consultant for future projects of NHAI/ MoRTH for a period of 6 months to 24 months depending upon the severity of case.

**4.5.3** Replacement after original contract period is over:

There shall be no limit on the replacements and no reduction in remunerations shall be made. The replacement shall however be of equal or better score.

**4.5.4** If the Employer (i) finds that any of the Personnel has committed serious misconduct or has been charged with having committed a criminal action or (ii) has reasonable ground to be dissatisfied with the performance of any of the Personnel, then the consultant shall, at the Employer's written request specifying the grounds therefore, forthwith provide a replacement with qualifications and experience acceptable to him.

**4.5.5** If the team leader or any other key personnel/ specialist considered pivotal to the project is replaced, the substitute may be interviewed by NHAI to assess their merit and suitability.

**4.5.6** If any member of the approved team of a consultant engaged by NHAI leaves that consultant before completion of the job, he shall be barred for a period of 6 months to 24 months from being engaged as a team member of any other consultant working (or to be appointed) for any other NHAI/ MoRTH projects.

**4.5.7** In exceptional situations where the replacement with equivalent or better qualification is not available, replacement with lower qualifications than the originally approved may be accepted with reduction in remuneration as per the procedure prescribed below. This kind of relaxation shall however, be limited to replacement of 2 key personnel only in one consultancy contract package.

i) The new proposed personnel as a replacement has to be evaluated as per the criteria fixed at the time of evaluation of original proposal and marks/rating and then:

-If the original personnel (included in the original proposal based on which the contract was awarded) is to be replaced at the instruction of NHAI and the new proposed personnel is having less qualification/ experience i.e marks/rating (but fulfilling the minimum requirement as per TOR), his remuneration would be reduced by 15% over and above the stipulated conditions in the contract because of less qualified personnel

-If the original personnel (included in Contract Agreement) is to be replaced by the Consulting firm and the new proposed personnel is having less qualification/ experience (marks/rating), then his remuneration would be decreased proportionally in comparison to the marks of the original personnel. This will also take into account the contract condition and if the proposed reduction is less than that stipulated in contract condition, it would be as per the contract provision.

It will be ensured that the new proposed personnel should score at least 75% of the marks of the originally approved key personnel. Both the Consulting firm and the proposed personnel should give the undertaking in the format available in Form VII of Appendix II along with the replacement CV.

ii) The CV should be signed by personnel and the consulting firm in every page. If the CV is found incorrect at later date, the personnel accepted would be removed from the assignment and debarred from further NHAI/ MoRTH works for an appropriate period to be decided by NHAI and the new proposed personnel in place of removed personnel would be paid 15% less salary than the original personnel. 15% reduction in the salary

will be imposed as penalty for submitting the incorrect information. This penalty will be imposed only once. If the same consulting firm submits incorrect information again second time, necessary action will be taken by NHAI to blacklist the firm.

#### **4.6 Resident Project Manager**

If required by the SC, the Consultants shall ensure that at all times during the Consultants' performance of the Services in the Government's country a resident project manager, acceptable to the Client, shall take charge of the performance of such Services.

### **5. OBLIGATION OF THE CLIENT**

5.1 Assistance and Exemptions unless otherwise specified in the SC, the Client shall use its best efforts to ensure that the Government shall:

(a) provide the Consultants, Sub consultants and Personnel with work permits and such other documents as shall be necessary to enable the Consultants, Sub consultants or Personnel to perform the Services;

(b) assist for the Personnel and, if appropriate, their eligible dependents to be provided promptly with all supporting papers for necessary entry and exit visas, residence permits, exchange permits and any other documents required for their stay in India;

(c) facilitate prompt clearance through customs of any property required for the Services;

(d) issue to officials, agents and representatives of the Government all such instructions as may be necessary or appropriate for the prompt and effective implementation of the Services;

#### **5.2 Access to Land**

The Client warrants that the Consultants shall have, free of charge, unimpeded access to all land in the Government's country in respect of which access is required for the performance of the Services. The Client will be responsible for any damage to such land or any property thereon resulting from such access and will indemnify the Consultants and each of the Personnel in respect of liability for any such damage, unless such damage is caused by the default or negligence of the Consultants or any Sub consultants or the Personnel of either of them.

#### **5.3 Change in the Applicable Law**

If, after the date of this Contract, there is any change in the Applicable Law with respect to taxes and duties which increases or decreases the cost or reimbursable expenses incurred by the Consultants in performing the Services, then the remuneration and reimbursable expenses otherwise payable to the Consultants under this Contract shall be increased or decreased accordingly by agreement between the Parties hereto, and corresponding adjustments shall be made to the ceiling amounts specified in Clause 6.1(b),

#### **5.4 Services, Facilities and Property of the Client**

The client shall make available to the Consultants and the Personnel, for the purposes of the Services and free of any charge, the services, facilities and property described in Appendix D at the times and in the manner specified in said Appendix D, provided that if such services, facilities and property shall not be made available to the Consultants as and when so

specified, the Parties shall agree on (i) any time extension that may be appropriate to grant to the Consultants for the performance of the Services, (ii) the manner in which the Consultants shall procure any such services, facilities and property from other sources, and (iii) the additional payments, if any, to be made to the Consultants as a result thereof pursuant to Clause 6.1(c) hereinafter.

## **5.5 Payment**

In consideration of the Services performed by the Consultants under this Contract, the Client shall make to the Consultants such payments and in such manner as is provided by Clause 6 of this Contract.

## **6. PAYMENT TO THE CONSULTANTS**

### **6.1 Cost Estimates: Ceiling Amount**

(a) An abstract of the cost of the Services payable in **local currency (Indian Rupees)** is set forth in **Appendix E**.

(b) Except as may be otherwise agreed under Clause 2.6 and subject to Clause 6.1(c), the payments under this Contract shall not exceed the ceiling specified in the SC. The Consultants shall notify the Client as soon as cumulative charges incurred for the Services have reached 80% of the ceiling.

(c) Notwithstanding Clause 6.1(b) hereof, if pursuant to Clauses 5.4 hereof, the Parties shall agree that additional payments shall be made to the Consultants in order to cover any necessary additional expenditures not envisaged in the cost estimates referred to in Clause 6.1(a) above, the ceiling set forth in Clause 6.1(b) above shall be increased by the amount or amounts, as the case may be, of any such additional payments.

### **6.2 Currency of Payment**

(a) The payment shall be made in Indian Rupees.

### **6.3 Mode of Billing and Payment**

Billing and payments in respect of the Services shall be made as follows:-

(a) The Client shall cause to be paid to the Consultants an advance payment as specified in the SC, and as otherwise set forth below. The advance payment will be due after provision by the Consultants to the Client of a bank guarantee by a bank acceptable to the Client in an amount (or amounts) and in a currency (or currencies) specified in the SC, such bank guarantee (i) to remain effective until the advance payment has been fully set off as provided in the SC, and ii) in such form as the Client shall have approved in writing.

**(b) Payment Schedule**

The Consultant will be paid stage-wise as a percentage of the contract value as per the schedule given below:

S. No	Item	Payment %
1	Submission of final QAP and Inception Report	10%
2	Approval of final Alignment Report	5%
3	Submission of final feasibility Report	5%
4	Submission Of 3a Notification, Draft 3 A And Approval Of Final Land Acquisition Report containing details of 3a, 3A	5%
5	Submission of all utilities shifting proposals to user agencies and submission of utilities relocation plan to NHAI	2.5%
6	Submission of all stage I clearance proposals and submission of clearances report to NHAI	5%
7	Approval of final DPR report, documents and drawings	10%
8	Approval of bid documents and draft civil works contract agreement along with technical schedules.	5%
9	3D publication for all land parcels identified in item 4 above and submission of Land Acquisition II report	10%
10	Stage II clearance approval and submission of final clearances II report	5%
11	Final approval of utilities shifting estimates and submission of Utilities II report	2.5%
12	Completion of award declaration (3G) for 90% of land parcels identified in item 9 and submission of Land Award report	10%
13	Earlier of award of package to contractor/concessionaire or 6 months from launch of tender process	10%
14	Receipt of land possession certificates (3E) for 90% of all land parcels identified in LA II report and submission of Land Possession report	10%
15	Amount to be released at earlier of projects COD or 3 years from start of civil work	5%
	Total :	100%

**Note:** Consultants have to provide a certificate that all key personnel as envisaged in the Contract Agreement has been actually deployed in the project. They have to submit this certificate at the time of submission of bills to NHAI from time to time.

\* The Concerned Project Director or his authorized representative shall ensure and certify at least 5% test check of all the data collected by the Consultant before releasing the payment to the Consultant.

(c) No payment shall become eligible for the next stage till the consultant completes to the satisfaction of the client the work pertaining to the preceding stage. The payment for the work of sub-soil investigation (Boring) will be as per plan approved by the client and will be paid as per actual at the rates quoted by the consultants. The payment for the quantity given by the client for boring will be deemed to be included in the above mentioned payment schedule. Any adjustment in the payment to the consultants will be made in the final payment only.

(d) The Client shall cause the payment of the Consultants in Para 6.4 (b) above as given in schedule of payment within thirty (30) days after the receipt by the Client of bills. Interests at the rate specified in the SC shall become payable as from the above due date on any amount due by, but not paid on, such due date.

(e) The final payment under this Clause shall be made only after the final report and a final statement, identified as such, shall have been submitted by the Consultants and approved as satisfactory by the Client. The Services shall be deemed completed and finally accepted by the Client and the final report and final statement shall be deemed approved by the Client as satisfactory one hundred and eighty (180) calendar days after receipt of the final report and final statement by the Client unless the Client, within ninety (90) day period, gives written notice to the Consultants specifying in detailed deficiencies in the Services, the final report or final statement. The Consultants shall thereupon promptly make any necessary corrections, and upon completion of such corrections, the foregoing process shall be repeated. Any amount which the Client has paid or caused to be paid in accordance with this Clause in excess of the amounts actually payable in accordance with the provisions of this Contract shall be reimbursed by the Consultants to the Client within thirty (30) days after receipt by the Consultants of notice thereof. Any such claim by the Client for reimbursement must be made within twelve (12) calendar months after receipt by the Client of a final report and a final statement approved by the Client in accordance with the above.

(f) All payments under this Contract shall be made to the account of the Consultants specified in the SC.

(g) Efforts need to be made by the Consultant to submit the schedule reports of each road stretch / s of a package. However, due to reasons beyond the reasonable control of Consultant, if the schedule submission of reports / documents of each road stretch / s of a package is not done, the payment shall be made on pro-rata basis.

## **7. Responsibility for Accuracy of Project Documents**

### **7.1 General**

7.1.1 The Consultant shall be responsible for accuracy of the data collected, by him directly or procured from other agencies/authorities, the designs, drawings, estimates and all other details prepared by him as part of these services. He shall indemnify the Authority against any inaccuracy in the work which might surface during implementation of the project. The Consultant will also be responsible for correcting, at his own cost and risk, the drawings including any re-survey / investigations and correcting layout etc. if required during the execution of the Services.

7.1.2 The Consultant shall be fully responsible for the accuracy of design and drawings of the bridges and structures. All the designs and drawings for bridges and structures including all their components shall be fully checked by a Senior Engineer after completion of the designs. All drawings for bridges and structures shall be duly signed by the (a) Designer, (b) Senior Checking Engineer, and (c) Senior Bridge / Structure Expert. The designs and drawings not signed by the three persons mentioned above shall not be accepted. The Consultant shall indemnify the Client against any inaccuracy / deficiency in the designs and drawings of the bridges and structures noticed during the construction and even thereafter and the Client shall bear no responsibility for the accuracy of the designs and drawings submitted by the Consultants.

7.1.3 The survey control points established by the Consultant shall be protected by the Consultants till the completion of the Consultancy Services.

## **7.2. Retention Money**

An amount equivalent to 15% of the contract value shall be retained at the end of the contract for accuracy of design and quantities submitted and the same will be released after the completion of civil contract works or after 3 years from completion of consultancy services, whichever is earlier. Out of this 15%, 10% shall be in the form of performance security and 5% shall be the amount retained from Consultancy fee payable to the Consultant.

## **7.3. Penalty**

### **7.3.1. Penalty for Error/Variation**

i. If variation in project cost occurs due to Change of scope requests of more than 10% of the total project cost as estimated by the consultant and these change of scope requests arise due to deficiencies in the design provided by the consultant, the penalty equivalent to 4% of the contract value shall be imposed. For this purpose retention money equivalent to 4% of the contract value will be forfeited. This shall exclude any additional/deletion of items/works ordered by the client during the execution

ii. If there is a discrepancy in land to be acquired during the execution of the project upto an extent of +/- 5% of the area of land, a penalty equivalent to 3% of the contract value shall be imposed. For this purpose retention money equivalent to 3% of the contract value will be forfeited. This shall exclude any additional/deletion of items/works ordered by the client during the execution

iii. If there is a variation in utilities shifting payments to be made during the execution of the project upto an extent of +/- 10% of the value estimated by the design consultant, a penalty equivalent to 3% of the contract value shall be imposed. For this purpose retention money equivalent to 3% of the contract value will be forfeited. This shall exclude any additional/deletion of items/works ordered by the client during the execution

iv) For inaccuracies in survey/investigation/design work the penalties shall be imposed as per details given in Table below:

Sr. No.	Item	Penalty (%age of contract value)
1	Topographic Surveys	0.5 to 1.0
	<i>a) The horizontal alignment does not match with ground condition.</i>	
	<i>b) The cross sections do not match with existing ground.</i>	
	<i>c) The co-ordinates are defective as instruments of desired accuracy not used.</i>	
2	Geotechnical Surveys	0.5 to 1.0
	<i>a)-Incomplete surveys</i>	
	<i>b) Data not analyzed properly</i>	
	<i>c) The substrata substantially different from the actual strata found during construction.</i>	
3	Traffic data found to be varying by more than 25% on resurvey at a later date, unless there are justifiable reasons.	0.2 to 0.5
4	Axle load data found to be varying by more than 25% on resurvey at a later date, unless there are justifiable reasons.	0.20 to 0.5
5	Structural Designs found to be unsafe or grossly over	1.0 to 2.0

### 7.3.2 Penalty for delay

In case of delay in completion of services, a penalty equal to 0.05% of the contract price per day subject to a maximum 5% of the contract value will be imposed and shall be recovered from payments due/performance security. However in case of delay due to reasons beyond the control of the consultant, suitable extension of time will be granted on case to case basis.

**7.3.3** Total amount of recovery from all penalties shall be limited to 15% of the Consultancy Fee.

**7.3.4** NHAI is in process of evolving performance based rating system for DPR Consultants. Performance of Consultants shall be monitored by NHAI and will be taken into account in technical evaluation of future DPR projects. For this purpose, performance of Consultant in the current project shall also be taken into account to create rating of Consultant.

## 7.4 ACTION FOR DEFICIENCY IN SERVICES

### 7.4.1 Consultants liability towards the Client

Consultant shall be liable to indemnify the client for any direct loss or damage accrued or likely to accrue due to deficiency in service rendered by him.

### 7.4.2 Warning / Debarring

In addition to the penalty as mentioned in para 7.3, warning may be issued to the erring consultants for minor deficiencies. In the case of major deficiencies in the Detailed Project Report involving time and cost overrun and adverse effect on reputation of NHAI, other penal action including debarring for certain period may also be initiated as per



policy of NHAI.

## **8. FAIRNESS AND GOOD FAITH**

### **8.1 Good Faith**

The Parties undertake to act in good faith with respect to each other's rights under this Contract and to adopt all reasonable measures to ensure the realization of the objectives of this Contract.

### **8.2 Operation of the Contract**

The Parties recognize that it is impractical in this Contract to provide for every contingency which may arise during the life of the Contract, and the Parties hereby agree that it is their intention that this Contract shall operate fairly as between them, and without detriment to the interest of either of them, and that, if during the term of this Contract either Party believes that this Contract is operating unfairly, the Parties will use their best efforts to agree on such action as may be necessary to remove the cause or causes of such unfairness, but no failure to agree on any action pursuant to this Clause shall give rise to a dispute subject to arbitration in accordance with Clause 9 hereof.

## **9. SETTLEMENT OF DISPUTES**

### **9.1 Amicable Settlement**

The Parties shall use their best efforts to settle amicably all disputes arising out of or in connection with this Contract or the interpretation thereof. In case of unsettled dispute arising out of the agreement, either party may require such dispute to be referred to the Chairman of NHAI and the head of the Consultant. The said two Authorities shall meet within 7 (seven) of the date of such request to discuss and attempt to amicably resolve the dispute. If such meeting doesn't take place within the said period or the dispute is not amicably settled within 15 (fifteen) days of such meeting between the said two authorities, either party may refer the dispute through arbitration as per the provisions of the agreement.

### **9.2 Dispute Settlement**

Any dispute between the Parties as to matters arising pursuant to this Contract which cannot be settled amicably within thirty (30) days after receipt by one Party of the other Party's request for such amicable settlement may be submitted by either Party for settlement in accordance with the provisions specified in the SC.

## **10. Change of Scope**

The change of Scope on account of variation of total length as well as 4 laned length of project Highway from the indicative length as given at Annex-1 of Letter of Invitation of the RFP shall be dealt as follows

i) During the course of consultancy services in case it is considered necessary to increase/decrease the scope of services (of total length or 4 laned length as compared to indicative Length as given in the RFP) by the client the same shall be notified by Change of scope notice. Similarly, if the Consultant determines that change of scope is needed, he shall inform of the same to the Client. The Client will examine and shall either reject the proposal or issue change of scope notice.

ii) The Consultancy fee shall be revised on account of change of scope as below:

- In case the total length of project increase/ decrease up to 10% of indicative length given in the RFP: **No change in Consultancy Fees.**
- In case the increase/ decrease in total length of project is more than 10 % of the indicative length as given in the RFP: The consultancy fee shall be increased/ decreased in the same proportion in which the length of the project road is increased/ decreased beyond 10% .

iii) Length of Bypass / realignment shall not be treated as additionality to the existing length of the highway for the purpose of change / variation in length. Increase/decrease in length on account of bypasses shall not be considered as change of scope. However, the total length of the project highway (including bypasses and realignment) along the finally approved alignment shall be compared with the indicative length in the RFP for the purpose of variation.

**10.1** The Consultancy fee shall be increased on account of change of scope as below:

- a) In case of Lanes increase in the project after the submission of Final Report: 10% of the original consultancy charges
- b) In case of change of mode of delivery is involved after submission of Final Report / due to revision of specifications / IRC Codes etc.

(i)	Revision of DPR after submission due to changes in IRC codes / specification etc.	2.5% of the original Consultancy charges.
(ii)	Revision of DPR due to changes in mode EPC / BOT / HAM etc	2.5% of the original Consultancy charges.

## SPECIAL CONDITIONS OF CONTRACT

Number of GC Clause

### A. Amendments of, and Supplements to, Clauses in the General Conditions

1.1(a) The words “in the Government’s country” are amended to read “in INDIA”

1.4 The language is: **English**

1.6.1 The addresses are:

**For the Client :** Chairman, National Highway Authority of India,  
G5&6, Sector-10, Dwarka, New Delhi-75

**Attention :** National Highways Authority of India,  
G5&6, Sector-10, Dwarka, New Delhi-75

011-25074100/ 4200 Extn. ....; Fax: 011-25093524

E-mail: sheoshankar@nhai.org

**For the Consultants:**

<b>Attention:</b>	<b>Name</b>			
	<b>Designation</b>			
	<b>Address</b>			
	<b>Tel:</b>	<b>Fax:</b>	<b>E-mail address</b>	

1.6.2 Notice will be deemed to be effective as follows:

- (a) in the case of personal delivery or registered mail, on delivery;
- (b) In the case of facsimiles, 24 hours following confirmed transmission.
- (c) In case of E mail, 24 hours following confirmed transmission.

1.8 Entity to Act as Member in charge (In case of Joint Venture of Consultants) with or without an Associate: - .....

1.9 The Authorized Representatives are:

**For the Client : ( -- )**  
Chairman, NHAI ( -- )

**For the Consultant:** Name  
Designation

1.10 The Consultants and the personnel shall pay the taxes, duties, fees, levies and other impositions levied under the existing, amended or enacted laws (prevailing 7 days before the last date of submission of bids) during life of this contract and the Client shall perform such duties in regard to the deduction of such tax as may be lawfully imposed.

2.1 The effectiveness conditions are the following:

a) The contract has been approved by NHAI.

b) The consultant will furnish within 15 days of the issue of letter of acceptance, an unconditional Bank Guarantee an amount equivalent to 10% of the total contract value to be received by him from a Nationalized Bank, IDBI or ICICI/ICICI Bank/Foreign Bank/EXIM Bank / Any Scheduled Commercial Bank approved by RBI having a net worth of not less than 500 crore as per latest Annual Report of the Bank. In the case of a Foreign Bank (issued by a Branch in India) the net worth in respect of Indian operations shall only be taken into account. In case of Foreign Bank, the BG issued by Foreign Bank should be counter guaranteed by any Nationalized Bank in India. In case of JV, the BG shall be furnished on behalf of the JV or lead partner of JV for an amount equivalent to 10 %of the total contract value to be received by him towards Performance Security valid for a period of **three years** beyond the date of completion of services.

2.2 The time period shall be “four months” or such other time period as the parties may agree in writing.

2.3 The time period shall be “fifteen days” or such other time period as the Parties may agree in writing.

2.4 The time period shall be ----- months or such other time period as the parties may agree in writing.

3.4 Limitation of the Consultants' Liability towards the Client

(a) Except in case of negligence or willful misconduct on the part of the Consultants or on the part of any person or firm acting on behalf of the Consultants in carrying out the Services, the Consultants, with respect to damage caused by the Consultants to the Client's property, shall not be liable to the Client:

(i) for any indirect or consequential loss or damage; and

(ii) for any direct loss or damage that exceeds (A) the total payments for Professional Fees and Reimbursable Expenditure made or expected to be made to the Consultants hereunder, or (B) the proceeds the Consultants may be entitled to receive from any insurance maintained by the Consultants to cover such a liability, whichever of (A) or (B) is higher.

(b) This limitation of liability shall not affect the Consultants' liability, if any, for damage to Third Parties caused by the Consultants or any person or firm acting on behalf of the Consultants in carrying out the Services.

3.5 The risks and the coverage shall be as follows:

(a) Third Party motor vehicle liability insurance as required under Motor Vehicles Act, 1988 in respect of motor vehicles operated in India by the Consultants or their Personnel or any Sub consultants or their Personnel for the period of consultancy.

(b) Third Party liability insurance with a minimum coverage, for Rs.1.00 million for the period of consultancy.

(c) (i) The Consultant shall provide to NHAI Professional Liability Insurance (PLI) for a period of **Five years** beyond completion of Consultancy services or as per Applicable Law, whichever is higher.

(ii) The Consultant will maintain at its expense PLI including coverage for errors and omissions caused by Consultant's negligence in the performance of its duties under this agreement, **(A)** For the amount not exceeding total payments for Professional Fees and Reimbursable Expenditures made or expected to be made to the Consultants hereunder OR **(B)** the proceeds, the Consultants may be entitled to receive from any insurance maintained by the Consultants to cover such a liability, whichever of **(A)** or **(B)** is higher.

iii) The policy should be issued only from an Insurance Company operating in India.

iv) The policy must clearly indicate the limit of indemnity in terms of "Any One Accident" (AOA) and "Aggregate limit on the policy" (AOP) and in no case should be for an amount less than stated in the contract.

v) If the Consultant enters into an agreement with NHAI in a joint venture or 'in association', the policy must be procured and provided to NHAI by the joint venture/in association entity and not by the individual partners of the joint venture/ association.

vi) The contract may include a provision whereby the Consultant does not cancel the policy midterm without the consent of NHAI. The insurance company may provide an undertaking in this regard.

(d) Employer's liability and workers' compensation insurance in respect of the Personnel of the Consultants and of any Sub consultant, in accordance with the relevant provisions of the Applicable Law, as well as, with respect to such Personnel, any such life, health, accident, travel or other insurance as may be appropriate; and all insurances and policies should start from the date of commencement of services and remain effective as per relevant requirements of contract agreement.

3.9 The Consultants shall not use these documents for purposes unrelated to this Contract without the prior written approval of the Client.

4.6 The person designated as Team Leader cum Senior Bridge Engineer in Appendix B shall serve in that capacity, as specified in Clause 4.6.

6.1 (b) The ceiling amount in local currency is Rs..... **Excluding Goods & Service Tax)**

6.3 (a) No advance payment will be made.

6.3 (e) The interest rate is: @ 12% per annum

6.3 (f) **The account is:**

9.2 Disputes shall be settled by arbitration in accordance with the following provisions:

### **9.2.1 Selection of Arbitrators**

Each dispute submitted by a Party to Arbitration shall be heard by a sole arbitrator. NHA shall within 30 days propose names of five (5) Arbitrators from the list of Arbitrators maintained by SAROD (Society for Affordable Redressal of Disputes) and Consultant shall within 30 days select one name from the list of five and the name so selected by the Consultant shall be the Sole Arbitrator for the matter in dispute. In case NHA delays in providing the list of 5 names, President, SAROD will provide 5 names within 30 days of receipt of reference from aggrieved party in this regard. In case the Consultant fails in selecting one from the list of five, President, SAROD shall select one from the list of five provided by NHA within 30 days of receipt of reference from aggrieved party in this regard.

### **9.2.2 Rules of Procedure**

Arbitration proceedings shall be conducted in accordance with the procedures of the Arbitration and Conciliation (Amendment) Act, 2015 of India unless the Consultant is a foreign national/ firm, where arbitration proceedings shall be conducted in accordance with the rules of procedure of arbitration of the United Nations Commission on International Trade Law (UNCITRAL) as in force on the date of this Contract.

### **9.2.3 Substitute Arbitrators**

If for any reason an arbitrator is unable to perform his function, a substitute shall be appointed in the same manner as the original arbitrator.

### **9.2.4 Qualifications of Arbitrators**

The list of five and the sole arbitrator selected pursuant to Clause 8.2.1 hereof shall be expert(s) with extensive experience in relation to the matter in dispute.

### **9.2.5 Miscellaneous**

In any arbitration proceeding hereunder:

- (a) Proceedings shall, unless otherwise agreed by the parties be held in Delhi.
- (b) The English language shall be the official language for all purposes;
- (c) The decision of sole arbitrator shall be final and binding and shall be enforceable in any court of competent jurisdiction, and the Parties hereby waive any objections to or claims of immunity in respect of such

enforcement; and

(d) Fee structure shall be as given below:

S. No.	Particulars of fee and other charges	Schedule Amount payable per Arbitrator / per case
1.	Arbitrator fee	<p>Rs.25,000/- per day</p> <p>Or</p> <p>Rs.7 lakhs (lump-sum) subject to publishing the Award within 6 months.</p> <p>Or</p> <p>Rs.5 lakhs (lump-sum) subject to publishing the Award after 6 months but before 12 months.</p> <p>Note:- The amount of fees already paid for the days of hearing @ Rs.25,000/- would be adjusted in the lump- sum payment.</p>
2.	Reading Charges	Rs.25,000/- per Arbitrator per case including counter claim.
3.	Secretarial Assistance and Incidental Charges (telephone, fax, postage etc.)	Rs.20,000/-
4.	Charges for Publishing / declaration of the Award	Rs.35,000/-
5.	Other expenses (As per actuals against bills subject to maximum of the prescribed ceiling given below)	<p>Economy class (by air), First class AC (by train) and AC car (by road)</p> <p>(a) Rs.15,000/- per day (Metro cities)</p> <p>(b) Rs.7,000/- per day (in other cities)</p> <p>(c) Rs.3,000/- per day, if any Arbitrator makes own arrangement.</p>
	Traveling Expenses and Lodging Boarding	

6.	Local Travel	Rs.1,500/- per day
7.	Extra charges for days other than hearing / meeting days (maximum for 2 days)	Rs.5,000/- per day for outstation Arbitrator
Note:	<ol style="list-style-type: none"> <li>1. Lodging, boarding and travelling expenses shall be allowed only for those members who are residing 100 kms. away from place of meeting.</li> <li>2. Delhi, Mumbai, Chennai, Kolkata, Bangalore and Hyderabad shall be considered as Metro Cities.</li> </ol>	



## Appendix A

---

Terms of reference containing, inter-alia, the Description of the Services and Reporting Requirements

## **Appendix B**

Consultants' Sub consultants, Key Personnel and Sub Professional Personnel

---

## Appendix C

### Hours of work for Consultants' Personnel

---

The Consultant's personnel shall normally work for 8 hours in a day and six days a week. Normally Sundays shall be closed for working. In addition they shall also be allowed to avail holidays as observed by the Client's office in the relevant state without deduction of remunerations. In case any person is required to work on Sunday or Holiday due to exigency of work, he/she shall be given compensatory leave within the next 15 days.

## Appendix D

### Duties of the Client

---

# Appendix E

## Cost Estimate

---

## Appendix F: Copy of letter of invitation

## Appendix G: Copy of letter of acceptance

## Appendix - H (I)

### Format for Bank Guarantee for Performance Security (For individual work) BANK GUARANTEE FOR PERFORMANCE SECURITY

To,  
Chairman  
National Highways Authority of India,  
G-5&6, Sector-10,  
Dwarka, New Delhi-110075

In consideration of "National Highways Authority of India" (hereinafter referred as the "Client", which expression shall, unless repugnant to the context or meaning thereof include its successors, administrators and assigns) having awarded to M/s.....having its office at ..... (Hereinafter referred to as the "Consultant" which expression shall repugnant to the context or meaning thereof, include its successors, administrators, executors and assigns), a contract by issue of client's Contract Agreement no. / Letter of Acceptance No. .... dated ..... and the same having been unequivocally accepted by the Consultant, resulting in a Contract valued at Rs...../- (Rupees.....) excluding Goods & service tax for "**Consultancy Services for preparation of Detailed Project Report of <Project Description> .....(Total Length -.....) on NH-.....** in the states of .....under - Contract Package No. .... (Hereinafter called the "Contract"), and the Consultant having agreed to furnish a Bank Guarantee to the Client as "Performance Security as stipulated by the Client in the said contract for performance of the above Contract amounting to Rs...../- (Rupees.....).

We, .....having registered office at ....., a body registered/constituted under the .....(hereinafter referred to as the Bank), which expression shall, unless repugnant to the context or meaning thereof, include its successors, administrators, executors and assigns) do hereby guarantee and undertake to pay the client immediately on demand any or, all money payable by the Consultant to the extent of Rs. ....(Rupees.....) as aforesaid at any time up to .....without any demur, reservation, contest, recourse or protest and/or without any reference to the consultant. Any such demand made by the client on the bank shall be conclusive and binding notwithstanding any difference between the Client and the Consultant or any dispute pending before any Court, Tribunal, Arbitrator or any other authority. We agree that the Guarantee herein contained shall be irrevocable and shall continue to be enforceable till the Client discharges this guarantee.

The Client shall have the fullest liberty without affecting in any way the liability of the Bank under this Guarantee, from time to time to vary or to extend the time for performance of the contract by the Consultant. The Client shall have the fullest liberty without affecting this guarantee, to postpone from time to time the exercise of any powers vested in them or of any right which they might have against the consultant and to exercise the same at any time in any manner, and either to enforce or to forbear to enforce any covenants, contained or implied, in the Contract between the Client and the Consultant any other course or remedy or security available to the



Client. The bank shall not be relieved of its obligations under these presents by any exercise by the Client of its liberty with reference to the matters aforesaid or any of them or by reason of any other act or forbearance or other acts of omission or commission on the part of the Client or any other indulgence shown by the Client or by any other matter or thing whatsoever which under law would but for this provision have the effect of relieving the Bank.

The Bank also agrees that the Client at its option shall be entitled to enforce this Guarantee against the Bank as a principal debtor, in the first instance without proceeding against the Consultant and notwithstanding any security or other guarantee that the Client may have in relation to the Consultant's liabilities.

Notwithstanding anything contained herein,

- a) Our liability under this Bank Guarantee is limited to Rs. ....(Rupees.....) and it shall remain in force up to and including .....and shall be extended from time to time for such period as may be desired by M/s....., on whose behalf this guarantee has been given.
- b) This Bank Guarantee shall be valid up to .....
- c) We are liable to pay the guaranteed amount or any part thereof under this Bank Guarantee only and only if you serve upon us a written claim or demand on or before .....(date of expiry of Guarantee).

(Signature of the Authorized Official)

(Name & Designation with Bank Stamp)

**NOTE:**

- (i)The bank guarantee(s) contains the name, designation and code number of the officer(s) signing the guarantee(s).
- (ii)The address, telephone no. and other details of the Head Office of the Bank as well as of issuing branch should be mentioned on the covering letter of issuing Branch.
- (iii)The bank guarantee for Rs 10,000 and above is signed by at least two officials (or as per the norms prescribed by the RBI in this regard).

## Appendix H (2):

### Format for Bank Guarantee for Performance Security for a number of works

To

(Name & Address of Authority)

In consideration of all consultancy works (hereinafter referred as the “Employer”, which expression shall, unless repugnant to the context or meaning thereof include its successors, administrators and assigns) awarded to M/s. .... Having its office at ..... (Hereinafter referred to as the “Consultant” which expression shall repugnant to the context or meaning thereof, include its successors, administrators, executors and assigns), by employer and the same having been unequivocally accepted or will be accepted by the Consultant, resulting in Contracts value upto Rs...../- (Rupees.....) excluding Goods & service tax and the Consultant having agreed to furnish a Bank Guarantee to the Employer as “Performance Security as stipulated by the Employer in the said contracts for performance of the consultancy Contracts undertaken or proposed to be undertaken in future date as a blanket security for compliance with his/its obligations in accordance with entire Contract(s) including contracts to be extended, modified, awarded and executed before the expiry of this Bank Guarantee or renewal thereof amounting to Rs...../- (Rupees.....).

We,.....having registered office at..... a body registered/constituted under the.....(hereinafter referred to as the Bank), which expression shall,, unless repugnant to the context or meaning thereof, include its successors, administrators, executors an assigns) do hereby guarantee and undertake to pay the employer immediately on demand any part or, all money payable by the consultant to the extent of Rs..... (Rupees.....) as aforesaid at any time up to ..... without any demur, reservation, context, recourse or protest and/or without any reference to the consultant. Any such demand made by the employer on the bank shall be conclusive and binding notwithstanding any difference between the employer and the Consultant or any dispute pending before any Court, Tribunal, Arbitrator or any other authority. We agree that the Guarantee herein contained shall be irrevocable and shall continue to be enforceable that is till expiry of this Bank Guarantee or renewal thereof.

The Employer shall have the fullest liberty without affecting in any way the liability of the Bank under this Guarantee, from time to time to vary or to extend the time for performance of the contracts by the Consultancy firm. The Employer shall have the fullest liberty without affecting this guarantee, to postpone from time to time the exercise of any powers vested in them or of any right which they might have against the consultant and to exercise the same at any time in any manner, and either to enforce or to forbear to enforce any covenants, contained or implied, in the Contract between the Employer and the Consultancy any other course or remedy or security available to the Employer. The bank shall not be relieved of its obligations under these presents by any exercise by the Employer of its liberty with reference to the matters aforesaid or any of them or by reason of any other act or forbearance or other acts of omission or

commission on the part of the Employer or any other indulgence shown by the Employer or by any other matter or thing whatsoever which under law would but for this provision have the effect of relieving the Bank The Bank also agrees that the Employer at its option shall be entitled to enforce this Guarantee against the Bank as a principal debtor, in the first instance without proceeding against the Consultant and notwithstanding any security or other security or other guarantee that the Employer may have in relation to the Consultant's liabilities.

Notwithstanding anything contained herein:

1. Our liability under this Omnibus Guarantee shall not exceed Rs.....  
(Rupees.....);
2. This Bank Guarantee shall be valid upto (Date (Month) Year); and (24 months).
3. We are liable to pay the guaranteed amount or any part thereof under this Bank Guarantee if you serve upon us a written claim or demand on or before..." (24 months). Thereafter, all your rights under this guarantee shall be forfeited and we shall be released from all our liabilities hereunder irrespective of whether the guarantee in original is returned to us or not.
- \*4. This guarantee shall also be operatable at our..... branch at New Delhi, from whom, confirmation regarding the issue of this guarantee or extension/renewal thereof shall be made available on demand. In the contingency of this guarantee being invoked and payment thereunder claimed, the said branch shall accept such invocation letter and make payment of amount so demanded under the said invocation.
5. This Bank Guarantee has been issued on the request of M/s.....

Signature and Seal of Guarantor.....

In presence of

Name and Designation

1. ....

Name of the Bank.....  
Occupation)

(Name, Signature &

Address.....

2. ....

.....

(Name & Occupation)

Date

\*This clause shall be kept for Bank Guarantees being issued outside Delhi.

**Appendix I: Minutes of Pre-bid meeting**

## APPENDIX-VII

### DPR Checklist - Stage 1 - Inception Report (Pavements)

General Details	
Project Name	
Consultant's Name	
Date of Review	

S.No	SECTION OF THE REPORT	YES/NO/NA	Details / Specifications	Remarks
1	<b>Executive Summary</b>	Yes <input type="checkbox"/> No <input type="checkbox"/> NA <input type="checkbox"/>	NA	
2	<b>Project Appreciation</b>	Yes <input type="checkbox"/> No <input type="checkbox"/> NA <input type="checkbox"/>	NA	
2.1	Location of site office	Yes <input type="checkbox"/> No <input type="checkbox"/> NA <input type="checkbox"/>		
2.2	Review of scope of ToR and gap identification	Yes <input type="checkbox"/> No <input type="checkbox"/> NA <input type="checkbox"/>	NA	
2.3	Key departments identified for various documents	Yes <input type="checkbox"/> No <input type="checkbox"/> NA <input type="checkbox"/>		
2.4	Start and end location of project verified with client (Mention details)	Yes <input type="checkbox"/> No <input type="checkbox"/> NA <input type="checkbox"/>		
2.5	Project description <ul style="list-style-type: none"> <li>• Start and End Chainage</li> <li>• Village/District</li> </ul>	Yes <input type="checkbox"/> No <input type="checkbox"/> NA <input type="checkbox"/>		
2.6	Project location map <ul style="list-style-type: none"> <li>• On State Map</li> <li>• On District Map</li> </ul>	Yes <input type="checkbox"/> No <input type="checkbox"/> NA <input type="checkbox"/>	NA	
2.7	Site photos and data of project alignment	Yes <input type="checkbox"/> No <input type="checkbox"/> NA <input type="checkbox"/>	NA	
2.8	Overview of land use plans	Yes <input type="checkbox"/> No <input type="checkbox"/> NA <input type="checkbox"/>	NA	
2.9	Overview of existing pavement conditions <ul style="list-style-type: none"> <li>• Number of Lanes</li> <li>• Type of Pavement (Flexible/Rigid/Surfaced/ Unsurfaced)</li> </ul>	Yes <input type="checkbox"/> No <input type="checkbox"/> NA <input type="checkbox"/>		
2.10	Existing right of way details	Yes <input type="checkbox"/> No <input type="checkbox"/> NA <input type="checkbox"/>		
2.11	Number/ Location of major and minor bridges	Yes <input type="checkbox"/> No <input type="checkbox"/> NA <input type="checkbox"/>		
2.12	Number/ Location of level crossings	Yes <input type="checkbox"/> No <input type="checkbox"/> NA <input type="checkbox"/>		
2.13	Number/ Location of ROB and RUB	Yes <input type="checkbox"/> No <input type="checkbox"/> NA <input type="checkbox"/>		
2.14	Any other details relevant to the project	Yes <input type="checkbox"/> No <input type="checkbox"/> NA <input type="checkbox"/>	NA	
3	<b>Approach Methodology</b>	Yes <input type="checkbox"/> No <input type="checkbox"/> NA <input type="checkbox"/>	NA	
3.1	Engineering survey and investigations	Yes <input type="checkbox"/> No <input type="checkbox"/> NA <input type="checkbox"/>	NA	
3.2	Design of road, pavements and structures	Yes <input type="checkbox"/> No <input type="checkbox"/> NA <input type="checkbox"/>	NA	
3.3	Environment and social impact assessment	Yes <input type="checkbox"/> No <input type="checkbox"/> NA <input type="checkbox"/>	NA	
3.4	Estimation of project cost, viability and financing options	Yes <input type="checkbox"/> No <input type="checkbox"/> NA <input type="checkbox"/>	NA	
3.5	Any other details relevant to the project	Yes <input type="checkbox"/> No <input type="checkbox"/> NA <input type="checkbox"/>	NA	

S.No	SECTION OF THE REPORT	YES/NO/NA	Details / Specifications	Remarks
4	<b>Task Assignment and Manning Schedule</b>	Yes <input type="checkbox"/> No <input type="checkbox"/> NA <input type="checkbox"/>	NA	
4.1	Number of key personnel provided	Yes <input type="checkbox"/> No <input type="checkbox"/> NA <input type="checkbox"/>		
4.2	Specific tasks assigned to each key personnel	Yes <input type="checkbox"/> No <input type="checkbox"/> NA <input type="checkbox"/>	NA	
4.3	Manning schedule for key personnel	Yes <input type="checkbox"/> No <input type="checkbox"/> NA <input type="checkbox"/>	NA	
4.4	Number of key personnel deployed at site	Yes <input type="checkbox"/> No <input type="checkbox"/> NA <input type="checkbox"/>		
5	<b>Performa for data collection</b>	Yes <input type="checkbox"/> No <input type="checkbox"/> NA <input type="checkbox"/>	NA	
6	<b>Indicative design standards and cross sections</b>	Yes <input type="checkbox"/> No <input type="checkbox"/> NA <input type="checkbox"/>	NA	
7	<b>Development plans</b>	Yes <input type="checkbox"/> No <input type="checkbox"/> NA <input type="checkbox"/>	NA	
7.1	Overview of development plans being implemented/ proposed by local bodies	Yes <input type="checkbox"/> No <input type="checkbox"/> NA <input type="checkbox"/>	NA	
7.2	Overview of impact of such development plans	Yes <input type="checkbox"/> No <input type="checkbox"/> NA <input type="checkbox"/>	NA	
8	<b>Quality Assurance Plan</b>	Yes <input type="checkbox"/> No <input type="checkbox"/> NA <input type="checkbox"/>	NA	
8.1	Engineering surveys and investigation	Yes <input type="checkbox"/> No <input type="checkbox"/> NA <input type="checkbox"/>	NA	
8.2	Traffic surveys	Yes <input type="checkbox"/> No <input type="checkbox"/> NA <input type="checkbox"/>	NA	
8.3	Material geo-technical and sub-soil investigations	Yes <input type="checkbox"/> No <input type="checkbox"/> NA <input type="checkbox"/>	NA	
8.4	Road and pavement investigations	Yes <input type="checkbox"/> No <input type="checkbox"/> NA <input type="checkbox"/>	NA	
8.5	Investigation and design of bridges and structures	Yes <input type="checkbox"/> No <input type="checkbox"/> NA <input type="checkbox"/>	NA	
8.6	Environment and R&R assessment	Yes <input type="checkbox"/> No <input type="checkbox"/> NA <input type="checkbox"/>	NA	
8.7	Economic and financial analysis	Yes <input type="checkbox"/> No <input type="checkbox"/> NA <input type="checkbox"/>	NA	
8.8	Drawing and documentation	Yes <input type="checkbox"/> No <input type="checkbox"/> NA <input type="checkbox"/>	NA	
8.9	Any other details relevant to the project	Yes <input type="checkbox"/> No <input type="checkbox"/> NA <input type="checkbox"/>	NA	
8.10	Discussion of draft QAP document with client	Yes <input type="checkbox"/> No <input type="checkbox"/> NA <input type="checkbox"/>	NA	
8.11	Approval of final QAP document by client	Yes <input type="checkbox"/> No <input type="checkbox"/> NA <input type="checkbox"/>	NA	
9	<b>Draft design Standards</b>	Yes <input type="checkbox"/> No <input type="checkbox"/> NA <input type="checkbox"/>	NA	
9.1	Geometric design standards of highway (Plain)	Yes <input type="checkbox"/> No <input type="checkbox"/> NA <input type="checkbox"/>	NA	
9.2	Geometric design standards of highway (Hilly)	Yes <input type="checkbox"/> No <input type="checkbox"/> NA <input type="checkbox"/>	NA	
10	<b>Conclusions and recommendations</b>	Yes <input type="checkbox"/> No <input type="checkbox"/> NA <input type="checkbox"/>	NA	
10.1	Conclusions and recommendations	Yes <input type="checkbox"/> No <input type="checkbox"/> NA <input type="checkbox"/>	NA	
10.2	Report fulfils project objectives and scope as per RFP	Yes <input type="checkbox"/> No <input type="checkbox"/> NA <input type="checkbox"/>	NA	
10.3	Report reviewed for errors and omissions	Yes <input type="checkbox"/> No <input type="checkbox"/> NA <input type="checkbox"/>	NA	
10.4	Compliance report prepared on client observations	Yes <input type="checkbox"/> No <input type="checkbox"/> NA <input type="checkbox"/>	NA	

## DPR Checklist - Stage 2 - Feasibility Report (Pavements)

General Details	
Project Name	
Consultant's Name	
Date of Review	

S.No	SECTION OF THE REPORT	YES/ NO/ NA	Details / Specifications	Remarks
1	<b>Executive Summary</b>	Yes <input type="checkbox"/> No <input type="checkbox"/> NA <input type="checkbox"/>	NA	
2	<b>Overview of client organization / activities</b>	Yes <input type="checkbox"/> No <input type="checkbox"/> NA <input type="checkbox"/>	NA	
3	<b>Methodology adopted for feasibility study</b>	Yes <input type="checkbox"/> No <input type="checkbox"/> NA <input type="checkbox"/>	NA	
4	<b>Socioeconomic profile of the project areas</b>	Yes <input type="checkbox"/> No <input type="checkbox"/> NA <input type="checkbox"/>	NA	
4.1	Regional economic profile basis last 10 years data as per IRC	Yes <input type="checkbox"/> No <input type="checkbox"/> NA <input type="checkbox"/>	NA	
4.2	Economic profile of project influence area basis last 10 years data as per IRC	Yes <input type="checkbox"/> No <input type="checkbox"/> NA <input type="checkbox"/>	NA	
4.3	Socio Economic status of project influence area	Yes <input type="checkbox"/> No <input type="checkbox"/> NA <input type="checkbox"/>	NA	
5	<b>Indicative design standards, methodologies, and specifications</b>	Yes <input type="checkbox"/> No <input type="checkbox"/> NA <input type="checkbox"/>	NA	
6	<b>Traffic surveys and analysis</b>	Yes <input type="checkbox"/> No <input type="checkbox"/> NA <input type="checkbox"/>	NA	
6.1	Classified traffic volume counts using IHMCL data (7 day data)	Yes <input type="checkbox"/> No <input type="checkbox"/> NA <input type="checkbox"/>	NA	
6.2	Traffic projection methodology as per IRC:108	Yes <input type="checkbox"/> No <input type="checkbox"/> NA <input type="checkbox"/>	NA	
6.3	Projected Traffic data for 20 years	Yes <input type="checkbox"/> No <input type="checkbox"/> NA <input type="checkbox"/>	NA	
6.4	Current and Projected PCU	Yes <input type="checkbox"/> No <input type="checkbox"/> NA <input type="checkbox"/>		
6.5	Current and Projected TVU	Yes <input type="checkbox"/> No <input type="checkbox"/> NA <input type="checkbox"/>		
6.6	Origin destination surveys as per IRC: 102	Yes <input type="checkbox"/> No <input type="checkbox"/> NA <input type="checkbox"/>	NA	
6.7	Speed and delay studies as per IRC:102	Yes <input type="checkbox"/> No <input type="checkbox"/> NA <input type="checkbox"/>	NA	
6.8	Traffic surveys for the design of road junctions as per data in IRC: SP:41	Yes <input type="checkbox"/> No <input type="checkbox"/> NA <input type="checkbox"/>	NA	
6.9	Analysis for replacing railway level crossings with over bridges/ subways	Yes <input type="checkbox"/> No <input type="checkbox"/> NA <input type="checkbox"/>	NA	
6.10	Axle load survey as per IRC:SP:19	Yes <input type="checkbox"/> No <input type="checkbox"/> NA <input type="checkbox"/>	NA	
6.11	Any other details relevant to the project	Yes <input type="checkbox"/> No <input type="checkbox"/> NA <input type="checkbox"/>	NA	
6.12	Traffic surveys monitored and reviewed by the client	Yes <input type="checkbox"/> No <input type="checkbox"/> NA <input type="checkbox"/>	NA	
7	<b>Reconnaissance survey</b>	Yes <input type="checkbox"/> No <input type="checkbox"/> NA <input type="checkbox"/>	NA	
7.1	Road Inventory Survey as per IRC:SP:19	Yes <input type="checkbox"/> No <input type="checkbox"/> NA <input type="checkbox"/>	NA	
7.2	Review of Road Inventory survey by client	Yes <input type="checkbox"/> No <input type="checkbox"/> NA <input type="checkbox"/>	NA	
7.3	Chainage wise details of pavement composition survey	Yes <input type="checkbox"/> No <input type="checkbox"/> NA <input type="checkbox"/>	NA	

S.No	SECTION OF THE REPORT	YES/ NO/ NA	Details / Specifications	Remarks
7.4	Geological Survey <ul style="list-style-type: none"> <li>Geological Map of the Area</li> <li>Seismicity</li> </ul>	Yes <input type="checkbox"/> No <input type="checkbox"/> NA <input type="checkbox"/>	NA	
7.5	Climatic Conditions <ul style="list-style-type: none"> <li>Temperature</li> <li>Rainfall</li> <li>Wind</li> </ul>	Yes <input type="checkbox"/> No <input type="checkbox"/> NA <input type="checkbox"/>	NA	
7.6	Pavement composition and condition survey as per IRC:SP:19	Yes <input type="checkbox"/> No <input type="checkbox"/> NA <input type="checkbox"/>	NA	
7.7	Review of pavement composition and condition survey by client	Yes <input type="checkbox"/> No <input type="checkbox"/> NA <input type="checkbox"/>	NA	
7.8	Pavement roughness survey as per IRC:SP:16	Yes <input type="checkbox"/> No <input type="checkbox"/> NA <input type="checkbox"/>	NA	
7.9	Review of pavement roughness survey by client	Yes <input type="checkbox"/> No <input type="checkbox"/> NA <input type="checkbox"/>	NA	
7.10	Pavement structural strength survey as per IRC:81	Yes <input type="checkbox"/> No <input type="checkbox"/> NA <input type="checkbox"/>	NA	
7.11	Review of pavement structural strength survey by client	Yes <input type="checkbox"/> No <input type="checkbox"/> NA <input type="checkbox"/>	NA	
7.12	Sub grade characteristics and strengths	Yes <input type="checkbox"/> No <input type="checkbox"/> NA <input type="checkbox"/>	NA	
7.13	Topographical survey as per IRC:SP:19 using LiDAR <ul style="list-style-type: none"> <li>Gradient</li> <li>Terrain</li> </ul>	Yes <input type="checkbox"/> No <input type="checkbox"/> NA <input type="checkbox"/>	NA	
7.14	Review of topographical survey by client	Yes <input type="checkbox"/> No <input type="checkbox"/> NA <input type="checkbox"/>	NA	
7.15	Inventory of bridges, culverts and structures	Yes <input type="checkbox"/> No <input type="checkbox"/> NA <input type="checkbox"/>	NA	
7.16	Condition survey for bridges, culverts and structures	Yes <input type="checkbox"/> No <input type="checkbox"/> NA <input type="checkbox"/>	NA	
7.17	Review of condition survey for bridges, culverts and structures by client	Yes <input type="checkbox"/> No <input type="checkbox"/> NA <input type="checkbox"/>	NA	
7.18	Any other details relevant to the project	Yes <input type="checkbox"/> No <input type="checkbox"/> NA <input type="checkbox"/>	NA	
8	<b>Geotechnical Survey</b>	Yes <input type="checkbox"/> No <input type="checkbox"/> NA <input type="checkbox"/>	NA	
8.1	Geo-technical and sub-soil explorations as per IRC:78	Yes <input type="checkbox"/> No <input type="checkbox"/> NA <input type="checkbox"/>	NA	
8.2	Bore holes dug for every pier and abutment	Yes <input type="checkbox"/> No <input type="checkbox"/> NA <input type="checkbox"/>	NA	
8.3	Review of geo-technical and sub-soil explorations by client	Yes <input type="checkbox"/> No <input type="checkbox"/> NA <input type="checkbox"/>	NA	
8.4	Field testing, soil sampling, laboratory testing in accordance with BIS/ AASHTO/ BS	Yes <input type="checkbox"/> No <input type="checkbox"/> NA <input type="checkbox"/>	NA	
8.5	Recommendation of Foundation Type and Depth	Yes <input type="checkbox"/> No <input type="checkbox"/> NA <input type="checkbox"/>	NA	
8.6	Any other details relevant to the project	Yes <input type="checkbox"/> No <input type="checkbox"/> NA <input type="checkbox"/>	NA	
9	<b>Hydraulic and Hydrological Survey</b>	Yes <input type="checkbox"/> No <input type="checkbox"/> NA <input type="checkbox"/>	NA	



S.No	SECTION OF THE REPORT	YES/ NO/ NA	Details / Specifications	Remarks
9.1	Hydraulic and hydrological investigations as per IRC:SP:13 and IRC:5	Yes <input type="checkbox"/> No <input type="checkbox"/> NA <input type="checkbox"/>	NA	
9.2	High Flood Level specified	Yes <input type="checkbox"/> No <input type="checkbox"/> NA <input type="checkbox"/>	NA	
9.3	Depth of Water Table specified	Yes <input type="checkbox"/> No <input type="checkbox"/> NA <input type="checkbox"/>	NA	
9.4	Ponded Water Level specified	Yes <input type="checkbox"/> No <input type="checkbox"/> NA <input type="checkbox"/>	NA	
9.5	Any other details relevant to the project	Yes <input type="checkbox"/> No <input type="checkbox"/> NA <input type="checkbox"/>	NA	
9.6	Review of hydrological investigations by client	Yes <input type="checkbox"/> No <input type="checkbox"/> NA <input type="checkbox"/>	NA	
10	<b>Materials Survey</b>	Yes <input type="checkbox"/> No <input type="checkbox"/> NA <input type="checkbox"/>	NA	
10.1	Materials Survey conducted as per IRC:SP:19	Yes <input type="checkbox"/> No <input type="checkbox"/> NA <input type="checkbox"/>	NA	
10.2	Sources of Naturally Occurring Aggregates specified <ul style="list-style-type: none"> <li>• Details of Borrow Pits with Distance from Project Site</li> <li>• Cost of Material/ Transportation</li> </ul>	Yes <input type="checkbox"/> No <input type="checkbox"/> NA <input type="checkbox"/>		
10.3	Sources of Manufactured Items specified <ul style="list-style-type: none"> <li>• Details of suppliers with distance from project site</li> <li>• Cost of material/ transportation</li> </ul>	Yes <input type="checkbox"/> No <input type="checkbox"/> NA <input type="checkbox"/>	NA	
10.4	Sources of water for construction specified as per IS: 456	Yes <input type="checkbox"/> No <input type="checkbox"/> NA <input type="checkbox"/>	NA	
10.5	Any other details relevant to the project	Yes <input type="checkbox"/> No <input type="checkbox"/> NA <input type="checkbox"/>	NA	
11	<b>Environmental screening/ preliminary environmental assessment</b>	Yes <input type="checkbox"/> No <input type="checkbox"/> NA <input type="checkbox"/>	NA	
11.1	Analysis basis Initial Environment Examination in IRC: SP: 19	Yes <input type="checkbox"/> No <input type="checkbox"/> NA <input type="checkbox"/>	NA	
11.2	Recommended feasible mitigation measures	Yes <input type="checkbox"/> No <input type="checkbox"/> NA <input type="checkbox"/>	NA	
12	<b>Initial social assessment/ preliminary LA resettlement plan</b>	Yes <input type="checkbox"/> No <input type="checkbox"/> NA <input type="checkbox"/>	NA	
12.1	Analysis basis Initial Environment Examination in IRC: SP: 19	Yes <input type="checkbox"/> No <input type="checkbox"/> NA <input type="checkbox"/>	NA	
12.2	Details of consultation with potentially affected persons	Yes <input type="checkbox"/> No <input type="checkbox"/> NA <input type="checkbox"/>	NA	
12.3	Names/ Details of consultation with local NGOs	Yes <input type="checkbox"/> No <input type="checkbox"/> NA <input type="checkbox"/>		
12.4	Names/ Details of consultation with municipal authorities	Yes <input type="checkbox"/> No <input type="checkbox"/> NA <input type="checkbox"/>		
12.5	Preliminary resettlement plan	Yes <input type="checkbox"/> No <input type="checkbox"/> NA <input type="checkbox"/>	NA	
12.6	Any other details relevant to the project	Yes <input type="checkbox"/> No <input type="checkbox"/> NA <input type="checkbox"/>	NA	
13	<b>Cost estimates</b>	Yes <input type="checkbox"/> No <input type="checkbox"/> NA <input type="checkbox"/>	NA	
13.1	Item rates and rate analysis	Yes <input type="checkbox"/> No <input type="checkbox"/> NA <input type="checkbox"/>	NA	
13.2	Escalation	Yes <input type="checkbox"/> No <input type="checkbox"/> NA <input type="checkbox"/>	NA	
14	<b>Economic and financial analysis</b>	Yes <input type="checkbox"/> No <input type="checkbox"/> NA <input type="checkbox"/>	NA	
14.1	Estimated cost details	Yes <input type="checkbox"/> No <input type="checkbox"/> NA <input type="checkbox"/>	NA	

S.No	SECTION OF THE REPORT	YES/ NO/ NA	Details / Specifications	Remarks
14.2	Projected revenues details	Yes <input type="checkbox"/> No <input type="checkbox"/> NA <input type="checkbox"/>	NA	
14.3	Assumptions stated	Yes <input type="checkbox"/> No <input type="checkbox"/> NA <input type="checkbox"/>	NA	
14.4	Analysis and results (IRR, Sensitivity Analysis, Financial Viability)	Yes <input type="checkbox"/> No <input type="checkbox"/> NA <input type="checkbox"/>	NA	
15	<b>Strip plan and Alignment</b>	Yes <input type="checkbox"/> No <input type="checkbox"/> NA <input type="checkbox"/>	NA	
15.1	Details of center line of proposed highway	Yes <input type="checkbox"/> No <input type="checkbox"/> NA <input type="checkbox"/>	NA	
15.2	Details of existing RoW	Yes <input type="checkbox"/> No <input type="checkbox"/> NA <input type="checkbox"/>	NA	
15.3	Details of proposed RoW	Yes <input type="checkbox"/> No <input type="checkbox"/> NA <input type="checkbox"/>	NA	
15.4	Details about ownership of land to be acquired	Yes <input type="checkbox"/> No <input type="checkbox"/> NA <input type="checkbox"/>	NA	
15.5	Strip plan basis reconnaissance and topographic surveys	Yes <input type="checkbox"/> No <input type="checkbox"/> NA <input type="checkbox"/>	NA	
15.6	Strip plan reviewed and approved by the client	Yes <input type="checkbox"/> No <input type="checkbox"/> NA <input type="checkbox"/>	NA	
16	<b>Alignment Options Study</b>	Yes <input type="checkbox"/> No <input type="checkbox"/> NA <input type="checkbox"/>	NA	
16.1	At least two alignments proposed • Details of Alignments on Map	Yes <input type="checkbox"/> No <input type="checkbox"/> NA <input type="checkbox"/>	NA	
16.2	Review of options with client	Yes <input type="checkbox"/> No <input type="checkbox"/> NA <input type="checkbox"/>	NA	
16.2.1	Review of options with local authority	Yes <input type="checkbox"/> No <input type="checkbox"/> NA <input type="checkbox"/>	NA	
16.3	Length of the project along proposed alignment options	Yes <input type="checkbox"/> No <input type="checkbox"/> NA <input type="checkbox"/>		
16.4	Land Acquisition required along alignment options	Yes <input type="checkbox"/> No <input type="checkbox"/> NA <input type="checkbox"/>		
16.4.1	Environmental impact of each option	Yes <input type="checkbox"/> No <input type="checkbox"/> NA <input type="checkbox"/>		
16.4.2	Review of road geometry and safety for each option	Yes <input type="checkbox"/> No <input type="checkbox"/> NA <input type="checkbox"/>		
16.5	Cost Estimates of alternatives	Yes <input type="checkbox"/> No <input type="checkbox"/> NA <input type="checkbox"/>		
16.6	Recommended Alignment with Justification	Yes <input type="checkbox"/> No <input type="checkbox"/> NA <input type="checkbox"/>	NA	
16.7	Any other details relevant to the project	Yes <input type="checkbox"/> No <input type="checkbox"/> NA <input type="checkbox"/>	NA	
17	<b>Technical Specifications</b>	Yes <input type="checkbox"/> No <input type="checkbox"/> NA <input type="checkbox"/>	NA	
17.1	MoRTH technical specifications for Roads and Bridge works followed	Yes <input type="checkbox"/> No <input type="checkbox"/> NA <input type="checkbox"/>	NA	
17.2	Details of technical specifications	Yes <input type="checkbox"/> No <input type="checkbox"/> NA <input type="checkbox"/>	NA	
18	<b>Rate Analysis</b>	Yes <input type="checkbox"/> No <input type="checkbox"/> NA <input type="checkbox"/>	NA	
18.1	Rate analysis for all relevant items as per latest SoR	Yes <input type="checkbox"/> No <input type="checkbox"/> NA <input type="checkbox"/>	NA	
19	<b>Cost Estimates</b>	Yes <input type="checkbox"/> No <input type="checkbox"/> NA <input type="checkbox"/>	NA	
19.1	Cost estimates for all relevant items as per latest SoR	Yes <input type="checkbox"/> No <input type="checkbox"/> NA <input type="checkbox"/>	NA	
20	<b>Bill of quantities</b>	Yes <input type="checkbox"/> No <input type="checkbox"/> NA <input type="checkbox"/>	NA	
21	<b>Conclusions and recommendations</b>	Yes <input type="checkbox"/> No <input type="checkbox"/> NA <input type="checkbox"/>	NA	
21.1	Conclusions and recommendations	Yes <input type="checkbox"/> No <input type="checkbox"/> NA <input type="checkbox"/>	NA	
21.2	Report fulfils project objectives and scope as per RFP	Yes <input type="checkbox"/> No <input type="checkbox"/> NA <input type="checkbox"/>	NA	

S.No	SECTION OF THE REPORT	YES/ NO/ NA	Details / Specifications	Remarks
21.3	Report reviewed for errors and omissions	Yes <input type="checkbox"/> No <input type="checkbox"/> NA <input type="checkbox"/>	NA	
21.4	Compliance report prepared on client observations	Yes <input type="checkbox"/> No <input type="checkbox"/> NA <input type="checkbox"/>	NA	

## DPR Checklist - Stage 3 - LA and Clearances I Report (Pavements)

General Details	
Project Name	
Consultant's Name	
Date of Review	

S.No	SECTION OF THE REPORT	YES/NO/NA	Details/ Specifications	Remarks
1	<b>Executive Summary</b>	Yes <input type="checkbox"/> No <input type="checkbox"/> NA <input type="checkbox"/>	NA	
2	<b>Strip plan- additional details added</b>	Yes <input type="checkbox"/> No <input type="checkbox"/> NA <input type="checkbox"/>	NA	
2.1	Details of centreline, existing structures, road furniture and other features	Yes <input type="checkbox"/> No <input type="checkbox"/> NA <input type="checkbox"/>	NA	
2.2	Widening scheme	Yes <input type="checkbox"/> No <input type="checkbox"/> NA <input type="checkbox"/>	NA	
2.3	New construction/ reconstruction of structures and amenities	Yes <input type="checkbox"/> No <input type="checkbox"/> NA <input type="checkbox"/>	NA	
2.4	Existing and proposed right of way	Yes <input type="checkbox"/> No <input type="checkbox"/> NA <input type="checkbox"/>	NA	
2.5	Clearances impacting each chainage	Yes <input type="checkbox"/> No <input type="checkbox"/> NA <input type="checkbox"/>	NA	
3	<b>Forest Clearance</b>	Yes <input type="checkbox"/> No <input type="checkbox"/> NA <input type="checkbox"/>	NA	
3.1	Requirement for forest clearance identified	Yes <input type="checkbox"/> No <input type="checkbox"/> NA <input type="checkbox"/>	NA	
3.2	Date/ Details of initial consultation with competent authority	Yes <input type="checkbox"/> No <input type="checkbox"/> NA <input type="checkbox"/>		
3.3	Details/cost of trees being felled basis concerned District Forest Office	Yes <input type="checkbox"/> No <input type="checkbox"/> NA <input type="checkbox"/>		
3.4	Date of submission of proposal for forest clearance	Yes <input type="checkbox"/> No <input type="checkbox"/> NA <input type="checkbox"/>	NA	
3.5	Review of proposal by client	Yes <input type="checkbox"/> No <input type="checkbox"/> NA <input type="checkbox"/>	NA	
4	<b>Wildlife Clearance</b>	Yes <input type="checkbox"/> No <input type="checkbox"/> NA <input type="checkbox"/>	NA	
4.1	Requirement for wildlife clearance identified	Yes <input type="checkbox"/> No <input type="checkbox"/> NA <input type="checkbox"/>	NA	
4.2	Date/ Details of initial consultation with competent authority	Yes <input type="checkbox"/> No <input type="checkbox"/> NA <input type="checkbox"/>		
4.3	Details/cost of trees being felled basis concerned District Forest Office	Yes <input type="checkbox"/> No <input type="checkbox"/> NA <input type="checkbox"/>		
4.4	Date of submission of proposal for wildlife clearance	Yes <input type="checkbox"/> No <input type="checkbox"/> NA <input type="checkbox"/>		
4.5	Review of proposal by client	Yes <input type="checkbox"/> No <input type="checkbox"/> NA <input type="checkbox"/>	NA	
5	<b>Utility Clearances (Electricity)</b>	Yes <input type="checkbox"/> No <input type="checkbox"/> NA <input type="checkbox"/>	NA	
5.1	Identification of overground utilities	Yes <input type="checkbox"/> No <input type="checkbox"/> NA <input type="checkbox"/>	NA	
5.2	Identification of underground utilities using GPR, Induction Locator or equivalent technologies	Yes <input type="checkbox"/> No <input type="checkbox"/> NA <input type="checkbox"/>	NA	
5.3	Name/ Details of consultation with local authority/ people	Yes <input type="checkbox"/> No <input type="checkbox"/> NA <input type="checkbox"/>		
5.4	Utility relocation plan with existing / proposed location showing existing RoW and topographic details	Yes <input type="checkbox"/> No <input type="checkbox"/> NA <input type="checkbox"/>	NA	
5.5	Cost for relocation as per authority	Yes <input type="checkbox"/> No <input type="checkbox"/> NA <input type="checkbox"/>		

S.No	SECTION OF THE REPORT	YES/NO/NA	Details/ Specifications	Remarks
5.6	Date of proposal submission to competent authority	Yes <input type="checkbox"/> No <input type="checkbox"/> NA <input type="checkbox"/>		
5.7	Review of utility relocation plan/ proposal by client	Yes <input type="checkbox"/> No <input type="checkbox"/> NA <input type="checkbox"/>	NA	
6	<b>Utility Clearances (Water)</b>	Yes <input type="checkbox"/> No <input type="checkbox"/> NA <input type="checkbox"/>	NA	
6.1	Identification of overground utilities in RoW	Yes <input type="checkbox"/> No <input type="checkbox"/> NA <input type="checkbox"/>	NA	
6.2	Identification of underground utilities using GPR, Induction Locator or equivalent technologies	Yes <input type="checkbox"/> No <input type="checkbox"/> NA <input type="checkbox"/>	NA	
6.3	Name/ Details of consultation with local authority/ people	Yes <input type="checkbox"/> No <input type="checkbox"/> NA <input type="checkbox"/>		
6.4	Utility relocation plan with existing / proposed location showing existing RoW and topographic details	Yes <input type="checkbox"/> No <input type="checkbox"/> NA <input type="checkbox"/>	NA	
6.5	Cost for relocation as per authority	Yes <input type="checkbox"/> No <input type="checkbox"/> NA <input type="checkbox"/>		
6.6	Date of proposal submission to competent authority	Yes <input type="checkbox"/> No <input type="checkbox"/> NA <input type="checkbox"/>	NA	
6.7	Review of utility relocation plan/ proposal by client	Yes <input type="checkbox"/> No <input type="checkbox"/> NA <input type="checkbox"/>	NA	
7	<b>Utility Clearances (Others)</b>	Yes <input type="checkbox"/> No <input type="checkbox"/> NA <input type="checkbox"/>	NA	
7.1	Identification of overground utilities in RoW	Yes <input type="checkbox"/> No <input type="checkbox"/> NA <input type="checkbox"/>	NA	
7.2	Identification of underground utilities using GPR, Induction Locator or equivalent technologies	Yes <input type="checkbox"/> No <input type="checkbox"/> NA <input type="checkbox"/>	NA	
7.3	Name/ Details of consultation with local authority/ people	Yes <input type="checkbox"/> No <input type="checkbox"/> NA <input type="checkbox"/>		
7.4	Utility relocation plan with existing / proposed location showing existing RoW and topographic details	Yes <input type="checkbox"/> No <input type="checkbox"/> NA <input type="checkbox"/>	NA	
7.5	Cost for relocation as per authority	Yes <input type="checkbox"/> No <input type="checkbox"/> NA <input type="checkbox"/>		
7.6	Date of proposal submission to competent authority	Yes <input type="checkbox"/> No <input type="checkbox"/> NA <input type="checkbox"/>		
7.7	Review of utility relocation plan/ proposal by client	Yes <input type="checkbox"/> No <input type="checkbox"/> NA <input type="checkbox"/>	NA	
8	<b>Railway Clearances</b>	Yes <input type="checkbox"/> No <input type="checkbox"/> NA <input type="checkbox"/>	NA	
8.1	Identification of ROB/ RUB on project corridor	Yes <input type="checkbox"/> No <input type="checkbox"/> NA <input type="checkbox"/>	NA	
8.2	Initial consultation with competent authority	Yes <input type="checkbox"/> No <input type="checkbox"/> NA <input type="checkbox"/>	NA	
8.3	Date of proposal submission to competent authority	Yes <input type="checkbox"/> No <input type="checkbox"/> NA <input type="checkbox"/>		
8.4	Review of GAD/ proposal by client	Yes <input type="checkbox"/> No <input type="checkbox"/> NA <input type="checkbox"/>	NA	
9	<b>Other Clearances</b>	Yes <input type="checkbox"/> No <input type="checkbox"/> NA <input type="checkbox"/>	NA	
9.1	Requirement for other clearances identified	Yes <input type="checkbox"/> No <input type="checkbox"/> NA <input type="checkbox"/>	NA	
9.2	Date of proposal submission to competent authority	Yes <input type="checkbox"/> No <input type="checkbox"/> NA <input type="checkbox"/>		
9.3	Review of proposal by client	Yes <input type="checkbox"/> No <input type="checkbox"/> NA <input type="checkbox"/>	NA	

S.No	SECTION OF THE REPORT	YES/NO/NA	Details/ Specifications	Remarks
10	<b>Land Acquisition</b>	Yes <input type="checkbox"/> No <input type="checkbox"/> NA <input type="checkbox"/>	NA	
10.1	Detailed schedule about acquisition of landholdings as per land records	Yes <input type="checkbox"/> No <input type="checkbox"/> NA <input type="checkbox"/>	NA	
10.2	Consultation with affected persons	Yes <input type="checkbox"/> No <input type="checkbox"/> NA <input type="checkbox"/>	NA	
10.3	Name/ Details of consultation with NGOs	Yes <input type="checkbox"/> No <input type="checkbox"/> NA <input type="checkbox"/>		
10.4	Name/ Details of consultation with concerned government agencies	Yes <input type="checkbox"/> No <input type="checkbox"/> NA <input type="checkbox"/>		
10.5	Total land required, land area already available , land to be acquired identified	Yes <input type="checkbox"/> No <input type="checkbox"/> NA <input type="checkbox"/>		
10.6	Review of land acquisition using digital cadastral map by client	Yes <input type="checkbox"/> No <input type="checkbox"/> NA <input type="checkbox"/>	NA	
10.7	Draft 3a notification submitted	Yes <input type="checkbox"/> No <input type="checkbox"/> NA <input type="checkbox"/>	NA	
10.8	Review of 3a notification by client	Yes <input type="checkbox"/> No <input type="checkbox"/> NA <input type="checkbox"/>	NA	
10.9	Date of 3a gazette notification	Yes <input type="checkbox"/> No <input type="checkbox"/> NA <input type="checkbox"/>		
10.10	Draft 3a notification submitted	Yes <input type="checkbox"/> No <input type="checkbox"/> NA <input type="checkbox"/>	NA	
10.11	Review of 3A notification by client	Yes <input type="checkbox"/> No <input type="checkbox"/> NA <input type="checkbox"/>	NA	
10.12	Date of 3A gazette notification	Yes <input type="checkbox"/> No <input type="checkbox"/> NA <input type="checkbox"/>		
11	<b>Conclusions and recommendations</b>	Yes <input type="checkbox"/> No <input type="checkbox"/> NA <input type="checkbox"/>	NA	
11.1	Conclusions and recommendations	Yes <input type="checkbox"/> No <input type="checkbox"/> NA <input type="checkbox"/>	NA	
11.2	Report fulfils project objectives and scope as per RFP	Yes <input type="checkbox"/> No <input type="checkbox"/> NA <input type="checkbox"/>	NA	
11.3	Report reviewed for errors and omissions	Yes <input type="checkbox"/> No <input type="checkbox"/> NA <input type="checkbox"/>	NA	
11.4	Compliance report prepared on client observations	Yes <input type="checkbox"/> No <input type="checkbox"/> NA <input type="checkbox"/>	NA	

## DPR Checklist - Stage 4 - Detailed Project Report (Pavements)

General Details	
Project Name	
Consultant's Name	
Date of Review	

S.No	SECTION OF THE REPORT	YES/NO/NA	Details / Specifications	Remarks
1	<b>Main Report</b>	Yes <input type="checkbox"/> No <input type="checkbox"/> NA <input type="checkbox"/>	NA	
2	<b>Introduction and project background</b>	Yes <input type="checkbox"/> No <input type="checkbox"/> NA <input type="checkbox"/>	NA	
2.1	Overview of project location, project objectives etc.	Yes <input type="checkbox"/> No <input type="checkbox"/> NA <input type="checkbox"/>	NA	
2.2	Overview of report structure, deliverables etc.	Yes <input type="checkbox"/> No <input type="checkbox"/> NA <input type="checkbox"/>	NA	
3	<b>Social analysis of the project</b>	Yes <input type="checkbox"/> No <input type="checkbox"/> NA <input type="checkbox"/>	NA	
3.1	Project impact on stakeholders such as local people	Yes <input type="checkbox"/> No <input type="checkbox"/> NA <input type="checkbox"/>	NA	
3.2	Project impact on residential, commercial and public properties	Yes <input type="checkbox"/> No <input type="checkbox"/> NA <input type="checkbox"/>	NA	
3.3	Any other details relevant to the project	Yes <input type="checkbox"/> No <input type="checkbox"/> NA <input type="checkbox"/>	NA	
4	<b>Reconnaissance survey</b>	Yes <input type="checkbox"/> No <input type="checkbox"/> NA <input type="checkbox"/>	NA	
4.1	Geometric Features of the Existing Road Design Speed <ul style="list-style-type: none"> <li>• Sight distance details</li> <li>• Horizontal Alignment Details</li> <li>• Vertical Alignment Details</li> <li>• Height of Embankment</li> </ul>	Yes <input type="checkbox"/> No <input type="checkbox"/> NA <input type="checkbox"/>		
4.2	Topographical Survey using LiDAR (or equivalent technology) as per IRC:SP:19 <ul style="list-style-type: none"> <li>• Gradient</li> <li>• Terrain</li> </ul>	Yes <input type="checkbox"/> No <input type="checkbox"/> NA <input type="checkbox"/>	NA	
4.3	Pavement composition and condition survey as per IRC:SP:19	Yes <input type="checkbox"/> No <input type="checkbox"/> NA <input type="checkbox"/>	NA	
4.4	Pavement roughness survey as per IRC:SP:16	Yes <input type="checkbox"/> No <input type="checkbox"/> NA <input type="checkbox"/>	Na	
4.5	Pavement structural strength survey as per IRC:81	Yes <input type="checkbox"/> No <input type="checkbox"/> NA <input type="checkbox"/>	NA	
4.6	Geological Survey <ul style="list-style-type: none"> <li>• Geological Map of the Area</li> <li>• Seismicity</li> </ul>	Yes <input type="checkbox"/> No <input type="checkbox"/> NA <input type="checkbox"/>	NA	
4.7	Climatic Conditions <ul style="list-style-type: none"> <li>• Temperature</li> <li>• Rainfall</li> <li>• Wind</li> </ul>	Yes <input type="checkbox"/> No <input type="checkbox"/> NA <input type="checkbox"/>	NA	
4.8	Land Use along the existing alignment <ul style="list-style-type: none"> <li>• Map of the Project Area depicting Agricultural/Habitation/Forest Area</li> </ul>	Yes <input type="checkbox"/> No <input type="checkbox"/> NA <input type="checkbox"/>	NA	

S.No	SECTION OF THE REPORT	YES/NO/NA	Details / Specifications	Remarks
4.9	Details of Existing Structures • Map of the Project Area depicting Hutments/Buildings/Temples/Public Building/Any Other Significant Structure	Yes <input type="checkbox"/> No <input type="checkbox"/> NA <input type="checkbox"/>	NA	
4.10	Inventory and condition survey of culverts	Yes <input type="checkbox"/> No <input type="checkbox"/> NA <input type="checkbox"/>	NA	
4.11	Geo-technical and sub-soil explorations as per IRC:78	Yes <input type="checkbox"/> No <input type="checkbox"/> NA <input type="checkbox"/>	NA	
4.12	Number of Bore holes dug (holes for every pier and abutment)	Yes <input type="checkbox"/> No <input type="checkbox"/> NA <input type="checkbox"/>		
4.13	Field testing, soil sampling, laboratory testing as per IRC: 78	Yes <input type="checkbox"/> No <input type="checkbox"/> NA <input type="checkbox"/>	NA	
4.14	Recommendation of Foundation Type and Depth	Yes <input type="checkbox"/> No <input type="checkbox"/> NA <input type="checkbox"/>		
4.15	Hydrological investigations as per IRC:5	Yes <input type="checkbox"/> No <input type="checkbox"/> NA <input type="checkbox"/>	NA	
4.16	High Flood Level specified	Yes <input type="checkbox"/> No <input type="checkbox"/> NA <input type="checkbox"/>	NA	
4.17	Depth of Water Table specified	Yes <input type="checkbox"/> No <input type="checkbox"/> NA <input type="checkbox"/>	NA	
4.18	Ponded Water Level specified	Yes <input type="checkbox"/> No <input type="checkbox"/> NA <input type="checkbox"/>	NA	
4.19	Materials Survey conducted as per IRC:SP:19	Yes <input type="checkbox"/> No <input type="checkbox"/> NA <input type="checkbox"/>	NA	
4.20	Sources of Naturally Occurring Aggregates specified • Details of Borrow Pits with Distance from Project Site • Cost of Material/Transportation	Yes <input type="checkbox"/> No <input type="checkbox"/> NA <input type="checkbox"/>		
4.20.1	Sources of environmentally friendly construction materials identified as per MoRT&H circular	Yes <input type="checkbox"/> No <input type="checkbox"/> NA <input type="checkbox"/>	NA	
4.21	Sources of Manufactured Items specified • Details of Suppliers with Distance from Project Site • Cost of Material/Transportation	Yes <input type="checkbox"/> No <input type="checkbox"/> NA <input type="checkbox"/>	NA	
4.22	Source of Water for construction specified as per IS:456	Yes <input type="checkbox"/> No <input type="checkbox"/> NA <input type="checkbox"/>	NA	
4.23	Any other details relevant to the project	Yes <input type="checkbox"/> No <input type="checkbox"/> NA <input type="checkbox"/>	NA	
5	<b>Traffic studies and demand forecast designs</b>	Yes <input type="checkbox"/> No <input type="checkbox"/> NA <input type="checkbox"/>	NA	
5.1	Classified traffic volume counts using IHMCL data (7 day data)	Yes <input type="checkbox"/> No <input type="checkbox"/> NA <input type="checkbox"/>	NA	
5.2	Traffic projection methodology as per IRC:108	Yes <input type="checkbox"/> No <input type="checkbox"/> NA <input type="checkbox"/>	NA	
5.3	Projected Traffic data for 20 years	Yes <input type="checkbox"/> No <input type="checkbox"/> NA <input type="checkbox"/>	NA	
5.4	Current and Projected PCU	Yes <input type="checkbox"/> No <input type="checkbox"/> NA <input type="checkbox"/>		
5.5	Current and Projected TVU	Yes <input type="checkbox"/> No <input type="checkbox"/> NA <input type="checkbox"/>		
5.6	Origin destination surveys as per IRC: 102	Yes <input type="checkbox"/> No <input type="checkbox"/> NA <input type="checkbox"/>	NA	
5.7	Speed and delay studies as per IRC:102	Yes <input type="checkbox"/> No <input type="checkbox"/> NA <input type="checkbox"/>	NA	



S.No	SECTION OF THE REPORT	YES/NO/NA	Details / Specifications	Remarks
5.8	Traffic surveys for the design of road junctions as per data in IRC: SP:41	Yes <input type="checkbox"/> No <input type="checkbox"/> NA <input type="checkbox"/>	NA	
5.9	Analysis for replacing railway level crossings with over bridges/ subways	Yes <input type="checkbox"/> No <input type="checkbox"/> NA <input type="checkbox"/>	NA	
5.10	Axle load survey as per IRC:SP:19	Yes <input type="checkbox"/> No <input type="checkbox"/> NA <input type="checkbox"/>	NA	
5.11	Any other details relevant to the project	Yes <input type="checkbox"/> No <input type="checkbox"/> NA <input type="checkbox"/>	NA	
5.12	Traffic surveys monitored and reviewed by the client	Yes <input type="checkbox"/> No <input type="checkbox"/> NA <input type="checkbox"/>	NA	
6	<b>Cost estimates</b>	Yes <input type="checkbox"/> No <input type="checkbox"/> NA <input type="checkbox"/>	NA	
6.1	Project costing as per latest SoR	Yes <input type="checkbox"/> No <input type="checkbox"/> NA <input type="checkbox"/>	NA	
7	<b>Environmental aspects</b>	Yes <input type="checkbox"/> No <input type="checkbox"/> NA <input type="checkbox"/>	NA	
7.1	Environment profile of the project region	Yes <input type="checkbox"/> No <input type="checkbox"/> NA <input type="checkbox"/>	NA	
7.2	Details of Public consultation at residential and commercial settlements affected	Yes <input type="checkbox"/> No <input type="checkbox"/> NA <input type="checkbox"/>	NA	
7.3	Impact analysis and mitigation measures	Yes <input type="checkbox"/> No <input type="checkbox"/> NA <input type="checkbox"/>	NA	
8	<b>Economic and commercial analysis</b>	Yes <input type="checkbox"/> No <input type="checkbox"/> NA <input type="checkbox"/>	NA	
8.1	Estimated cost details	Yes <input type="checkbox"/> No <input type="checkbox"/> NA <input type="checkbox"/>	NA	
8.2	Projected revenues details	Yes <input type="checkbox"/> No <input type="checkbox"/> NA <input type="checkbox"/>	NA	
8.3	Assumptions stated	Yes <input type="checkbox"/> No <input type="checkbox"/> NA <input type="checkbox"/>	NA	
8.4	Analysis and results (IRR, Sensitivity Analysis, Financial Viability)	Yes <input type="checkbox"/> No <input type="checkbox"/> NA <input type="checkbox"/>	NA	
8.5	Conclusions and recommendations	Yes <input type="checkbox"/> No <input type="checkbox"/> NA <input type="checkbox"/>	NA	
8.6	Financial model shared with client and reviewed	Yes <input type="checkbox"/> No <input type="checkbox"/> NA <input type="checkbox"/>	NA	
9	<b>Conclusions and recommendations</b>	Yes <input type="checkbox"/> No <input type="checkbox"/> NA <input type="checkbox"/>	NA	
9.1	Report fulfils project objectives and scope as per RFP	Yes <input type="checkbox"/> No <input type="checkbox"/> NA <input type="checkbox"/>	NA	
9.2	Report reviewed for errors and omissions	Yes <input type="checkbox"/> No <input type="checkbox"/> NA <input type="checkbox"/>	NA	
9.3	Compliance report prepared on client observations	Yes <input type="checkbox"/> No <input type="checkbox"/> NA <input type="checkbox"/>	NA	
10	<b>Design Report</b>	Yes <input type="checkbox"/> No <input type="checkbox"/> NA <input type="checkbox"/>	NA	
10.1	Highway improvement proposals	Yes <input type="checkbox"/> No <input type="checkbox"/> NA <input type="checkbox"/>	NA	
10.2	Highway geometric designs	Yes <input type="checkbox"/> No <input type="checkbox"/> NA <input type="checkbox"/>	NA	
10.3	Roadside drainage	Yes <input type="checkbox"/> No <input type="checkbox"/> NA <input type="checkbox"/>	NA	
10.4	Intersections	Yes <input type="checkbox"/> No <input type="checkbox"/> NA <input type="checkbox"/>	NA	
10.5	Urban service roads	Yes <input type="checkbox"/> No <input type="checkbox"/> NA <input type="checkbox"/>	NA	
10.6	Bus-stops	Yes <input type="checkbox"/> No <input type="checkbox"/> NA <input type="checkbox"/>	NA	
10.7	Toll plazas	Yes <input type="checkbox"/> No <input type="checkbox"/> NA <input type="checkbox"/>	NA	
10.8	Pedestrian crossings	Yes <input type="checkbox"/> No <input type="checkbox"/> NA <input type="checkbox"/>	NA	
10.9	Utility relocation	Yes <input type="checkbox"/> No <input type="checkbox"/> NA <input type="checkbox"/>	NA	
10.10	Pavement	Yes <input type="checkbox"/> No <input type="checkbox"/> NA <input type="checkbox"/>	NA	
10.11	Structures	Yes <input type="checkbox"/> No <input type="checkbox"/> NA <input type="checkbox"/>	NA	
10.12	Any other details relevant to the project	Yes <input type="checkbox"/> No <input type="checkbox"/> NA <input type="checkbox"/>	NA	

S.No	SECTION OF THE REPORT	YES/NO/NA	Details / Specifications	Remarks
10.13	Pavement deflection survey as per IRC 81-1997	Yes <input type="checkbox"/> No <input type="checkbox"/> NA <input type="checkbox"/>	NA	
10.14	Any other details relevant to the project	Yes <input type="checkbox"/> No <input type="checkbox"/> NA <input type="checkbox"/>	NA	
11	<b>Materials Report</b>	Yes <input type="checkbox"/> No <input type="checkbox"/> NA <input type="checkbox"/>	NA	
11.1	Material investigations as per IRC:10	Yes <input type="checkbox"/> No <input type="checkbox"/> NA <input type="checkbox"/>	NA	
11.2	Review of material investigations by client	Yes <input type="checkbox"/> No <input type="checkbox"/> NA <input type="checkbox"/>	NA	
11.3	Multiple borrow areas identified	Yes <input type="checkbox"/> No <input type="checkbox"/> NA <input type="checkbox"/>	NA	
11.4	Material survey as per IRC: SP: 19	Yes <input type="checkbox"/> No <input type="checkbox"/> NA <input type="checkbox"/>	NA	
11.5	Review of material survey by client	Yes <input type="checkbox"/> No <input type="checkbox"/> NA <input type="checkbox"/>	NA	
11.6	Geo-technical and sub-soil explorations as per IRC:78	Yes <input type="checkbox"/> No <input type="checkbox"/> NA <input type="checkbox"/>	NA	
11.7	Review of geo-technical and sub-soil explorations by client	Yes <input type="checkbox"/> No <input type="checkbox"/> NA <input type="checkbox"/>	NA	
11.8	Field testing, soil sampling, laboratory testing in accordance with BIS/ AASHTO/ BS	Yes <input type="checkbox"/> No <input type="checkbox"/> NA <input type="checkbox"/>	NA	
11.9	Pavement composition and condition survey as per IRC:SP:19	Yes <input type="checkbox"/> No <input type="checkbox"/> NA <input type="checkbox"/>	NA	
11.10	Review of pavement composition and condition survey by client	Yes <input type="checkbox"/> No <input type="checkbox"/> NA <input type="checkbox"/>	NA	
11.11	Pavement roughness survey as per IRC:SP:16	Yes <input type="checkbox"/> No <input type="checkbox"/> NA <input type="checkbox"/>	NA	
11.12	Review of pavement roughness survey by client	Yes <input type="checkbox"/> No <input type="checkbox"/> NA <input type="checkbox"/>	NA	
11.13	Pavement structural strength survey as per IRC:81	Yes <input type="checkbox"/> No <input type="checkbox"/> NA <input type="checkbox"/>	NA	
11.14	Review of pavement structural strength survey by client	Yes <input type="checkbox"/> No <input type="checkbox"/> NA <input type="checkbox"/>	NA	
11.15	Water sample tests as per MoRTH specifications	Yes <input type="checkbox"/> No <input type="checkbox"/> NA <input type="checkbox"/>	NA	
11.16	Any other details relevant to the project	Yes <input type="checkbox"/> No <input type="checkbox"/> NA <input type="checkbox"/>	NA	
12	<b>Environmental Assessment Report/ Resettlement and Rehabilitation Plan</b>	Yes <input type="checkbox"/> No <input type="checkbox"/> NA <input type="checkbox"/>	NA	
12.1	Option for alignment alternatives considered and conclusions	Yes <input type="checkbox"/> No <input type="checkbox"/> NA <input type="checkbox"/>	NA	
12.2	Land environment data collection and details/ impact/ mitigation measures	Yes <input type="checkbox"/> No <input type="checkbox"/> NA <input type="checkbox"/>	NA	
12.3	Air environment data collection and details/ impact/ mitigation measures	Yes <input type="checkbox"/> No <input type="checkbox"/> NA <input type="checkbox"/>	NA	
12.4	Water resources details/ impact/ mitigation measures	Yes <input type="checkbox"/> No <input type="checkbox"/> NA <input type="checkbox"/>	NA	
12.5	Noise environment details/ impact/ mitigation measures	Yes <input type="checkbox"/> No <input type="checkbox"/> NA <input type="checkbox"/>	NA	
12.6	Biological environment details/ impact/ mitigation measures	Yes <input type="checkbox"/> No <input type="checkbox"/> NA <input type="checkbox"/>	NA	
12.7	Details of public consultation	Yes <input type="checkbox"/> No <input type="checkbox"/> NA <input type="checkbox"/>	NA	

S.No	SECTION OF THE REPORT	YES/NO/NA	Details / Specifications	Remarks
12.8	Environment monitoring and management plan	Yes <input type="checkbox"/> No <input type="checkbox"/> NA <input type="checkbox"/>	NA	
12.9	Details of social impact assessment	Yes <input type="checkbox"/> No <input type="checkbox"/> NA <input type="checkbox"/>	NA	
12.10	Details of resettlement and rehabilitation action plan	Yes <input type="checkbox"/> No <input type="checkbox"/> NA <input type="checkbox"/>	NA	
12.11	Measures to minimize resettlement	Yes <input type="checkbox"/> No <input type="checkbox"/> NA <input type="checkbox"/>	NA	
12.12	Details of public consultation with stakeholders	Yes <input type="checkbox"/> No <input type="checkbox"/> NA <input type="checkbox"/>	NA	
12.13	Details of implementation arrangement / budget	Yes <input type="checkbox"/> No <input type="checkbox"/> NA <input type="checkbox"/>	NA	
12.14	Any other details relevant to the project	Yes <input type="checkbox"/> No <input type="checkbox"/> NA <input type="checkbox"/>	NA	
13	<b>Technical Specifications</b>	Yes <input type="checkbox"/> No <input type="checkbox"/> NA <input type="checkbox"/>	NA	
13.1	MoRTH technical specifications for Roads and Bridge works followed	Yes <input type="checkbox"/> No <input type="checkbox"/> NA <input type="checkbox"/>	NA	
13.2	Details of technical specifications	Yes <input type="checkbox"/> No <input type="checkbox"/> NA <input type="checkbox"/>	NA	
14	<b>Rate Analysis</b>	Yes <input type="checkbox"/> No <input type="checkbox"/> NA <input type="checkbox"/>	NA	
14.1	Rate analysis for all relevant items as per latest SoR	Yes <input type="checkbox"/> No <input type="checkbox"/> NA <input type="checkbox"/>	NA	
15	<b>Cost Estimates</b>	Yes <input type="checkbox"/> No <input type="checkbox"/> NA <input type="checkbox"/>	NA	
15.1	Cost estimates for all relevant items as per latest SoR	Yes <input type="checkbox"/> No <input type="checkbox"/> NA <input type="checkbox"/>	NA	
16	<b>Bill of quantities</b>	Yes <input type="checkbox"/> No <input type="checkbox"/> NA <input type="checkbox"/>	NA	
17	<b>Drawing Volume</b>	Yes <input type="checkbox"/> No <input type="checkbox"/> NA <input type="checkbox"/>	NA	
18	<b>Digital drawings of road</b>			
18.1	Highway cross sections	Yes <input type="checkbox"/> No <input type="checkbox"/> NA <input type="checkbox"/>		
18.2	3D engineered models of: <ul style="list-style-type: none"> <li>• Road alignment geometry</li> <li>• Proposed highway</li> <li>• Proposed structures</li> </ul>	Yes <input type="checkbox"/> No <input type="checkbox"/> NA <input type="checkbox"/>		

## DPR Checklist - Stage 5 - Technical Schedules (Pavements)

General Details	
Project Name	
Consultant's Name	
Date of Review	

S.No	SECTION OF THE REPORT	YES/NO/NA	Details / Specifications	Remarks
1	Bid documents- EPC	Yes <input type="checkbox"/> No <input type="checkbox"/> NA <input type="checkbox"/>	NA	
2	Bid documents- BOT/PPP	Yes <input type="checkbox"/> No <input type="checkbox"/> NA <input type="checkbox"/>	NA	
3	Bid documents- other, if any	Yes <input type="checkbox"/> No <input type="checkbox"/> NA <input type="checkbox"/>	NA	
4	Draft concession agreement	Yes <input type="checkbox"/> No <input type="checkbox"/> NA <input type="checkbox"/>	NA	
4	Schedule D - Specifications and standards	Yes <input type="checkbox"/> No <input type="checkbox"/> NA <input type="checkbox"/>	NA	
5	Any other relevant details	Yes <input type="checkbox"/> No <input type="checkbox"/> NA <input type="checkbox"/>	NA	

## DPR Checklist - Stage 6 - LA and Clearances II Report (Pavements)

General Details	
Project Name	
Consultant's Name	
Date of Review	

S.No	SECTION OF THE REPORT	YES/NO/NA	Details/ Specifications	Remarks
1	<b>Executive Summary</b>	Yes <input type="checkbox"/> No <input type="checkbox"/> NA <input type="checkbox"/>	NA	
2	<b>Environment Clearance</b>	Yes <input type="checkbox"/> No <input type="checkbox"/> NA <input type="checkbox"/>	NA	
2.1	Details of public hearings completed	Yes <input type="checkbox"/> No <input type="checkbox"/> NA <input type="checkbox"/>		
2.2	Date of final environment clearance by competent authority	Yes <input type="checkbox"/> No <input type="checkbox"/> NA <input type="checkbox"/>		
3	<b>Forest Clearance</b>	Yes <input type="checkbox"/> No <input type="checkbox"/> NA <input type="checkbox"/>	NA	
3.1	Date/ Details of Joint site inspection with DFO/ competent authority	Yes <input type="checkbox"/> No <input type="checkbox"/> NA <input type="checkbox"/>		
3.2	Date of Stage I forest clearance approval by competent authority	Yes <input type="checkbox"/> No <input type="checkbox"/> NA <input type="checkbox"/>		
3.3	Date of final forest clearance approval by competent authority	Yes <input type="checkbox"/> No <input type="checkbox"/> NA <input type="checkbox"/>		
4	<b>Wildlife Clearance</b>	Yes <input type="checkbox"/> No <input type="checkbox"/> NA <input type="checkbox"/>	NA	
4.1	Date/ Details of joint site inspection with DFO/ competent authority	Yes <input type="checkbox"/> No <input type="checkbox"/> NA <input type="checkbox"/>		
4.2	Date of final wildlife clearance approval by competent authority	Yes <input type="checkbox"/> No <input type="checkbox"/> NA <input type="checkbox"/>		
5	<b>Utility Clearances (Electricity)</b>	Yes <input type="checkbox"/> No <input type="checkbox"/> NA <input type="checkbox"/>	NA	
5.1	Date/ Details of Joint site inspection with competent authority	Yes <input type="checkbox"/> No <input type="checkbox"/> NA <input type="checkbox"/>		
5.2	Date of estimate submission by competent authority	Yes <input type="checkbox"/> No <input type="checkbox"/> NA <input type="checkbox"/>		
5.3	Date of estimate approval by competent authority	Yes <input type="checkbox"/> No <input type="checkbox"/> NA <input type="checkbox"/>		
5.4	Approved utility shifting proposal including strip plan	Yes <input type="checkbox"/> No <input type="checkbox"/> NA <input type="checkbox"/>		
5.5	Details of approved contractors, SoR and deposit details for user agency	Yes <input type="checkbox"/> No <input type="checkbox"/> NA <input type="checkbox"/>	NA	
5.6	Utilities checklist, no upgradation certificate attached	Yes <input type="checkbox"/> No <input type="checkbox"/> NA <input type="checkbox"/>		
6.2	Date of estimate submission by competent authority	Yes <input type="checkbox"/> No <input type="checkbox"/> NA <input type="checkbox"/>		
6.3	Date of estimate approval by competent authority	Yes <input type="checkbox"/> No <input type="checkbox"/> NA <input type="checkbox"/>		
6.4	Approved utility shifting proposal including strip plan	Yes <input type="checkbox"/> No <input type="checkbox"/> NA <input type="checkbox"/>		
6.5	Details of approved contractors, SoR and deposit details for user agency	Yes <input type="checkbox"/> No <input type="checkbox"/> NA <input type="checkbox"/>	NA	
6.6	Utilities checklist, no upgradation certificate attached	Yes <input type="checkbox"/> No <input type="checkbox"/> NA <input type="checkbox"/>		

S.No	SECTION OF THE REPORT	YES/NO/NA	Details/ Specifications	Remarks
7.2	Date of estimate submission by competent authority	Yes <input type="checkbox"/> No <input type="checkbox"/> NA <input type="checkbox"/>		
7.3	Date of estimate approval by competent authority	Yes <input type="checkbox"/> No <input type="checkbox"/> NA <input type="checkbox"/>		
7.4	Approved utility shifting proposal including strip plan	Yes <input type="checkbox"/> No <input type="checkbox"/> NA <input type="checkbox"/>		
7.5	Details of approved contractors, SoR and deposit details for user agency	Yes <input type="checkbox"/> No <input type="checkbox"/> NA <input type="checkbox"/>	NA	
7.6	Utilities checklist, no upgradation certificate attached	Yes <input type="checkbox"/> No <input type="checkbox"/> NA <input type="checkbox"/>		
8.2	Date of final approval of GAD by competent authority	Yes <input type="checkbox"/> No <input type="checkbox"/> NA <input type="checkbox"/>		
9	<b>Other Clearances</b>	Yes <input type="checkbox"/> No <input type="checkbox"/> NA <input type="checkbox"/>	NA	
9.1	Date of final approval by competent authority	Yes <input type="checkbox"/> No <input type="checkbox"/> NA <input type="checkbox"/>		
10	<b>Land Acquisition</b>	Yes <input type="checkbox"/> No <input type="checkbox"/> NA <input type="checkbox"/>	NA	
10.1	Draft 3a notification submitted	Yes <input type="checkbox"/> No <input type="checkbox"/> NA <input type="checkbox"/>		
10.2	Review of 3a notification by client	Yes <input type="checkbox"/> No <input type="checkbox"/> NA <input type="checkbox"/>		
10.3	Date of 3a gazette notification	Yes <input type="checkbox"/> No <input type="checkbox"/> NA <input type="checkbox"/>		
10.4	Draft 3a notification submitted	Yes <input type="checkbox"/> No <input type="checkbox"/> NA <input type="checkbox"/>		
10.5	Review of 3A notification by client	Yes <input type="checkbox"/> No <input type="checkbox"/> NA <input type="checkbox"/>		
10.6	Date of 3A gazette notification	Yes <input type="checkbox"/> No <input type="checkbox"/> NA <input type="checkbox"/>		
10.7	Date of Joint Measurement Survey with competent authority	Yes <input type="checkbox"/> No <input type="checkbox"/> NA <input type="checkbox"/>		
10.7.1	Date of survey - village wise	Yes <input type="checkbox"/> No <input type="checkbox"/> NA <input type="checkbox"/>	NA	
10.7.2	Land type –by survey number	Yes <input type="checkbox"/> No <input type="checkbox"/> NA <input type="checkbox"/>	NA	
10.7.3	Nature of Land –by survey number	Yes <input type="checkbox"/> No <input type="checkbox"/> NA <input type="checkbox"/>	NA	
10.7.4	Ownership status of plots- by survey number	Yes <input type="checkbox"/> No <input type="checkbox"/> NA <input type="checkbox"/>	NA	
10.7.5	Verification of area to be acquired – by survey number	Yes <input type="checkbox"/> No <input type="checkbox"/> NA <input type="checkbox"/>	NA	
10.7.6	List of structures on each plot	Yes <input type="checkbox"/> No <input type="checkbox"/> NA <input type="checkbox"/>	NA	
10.7.7	Sketches of updated alignment by village	Yes <input type="checkbox"/> No <input type="checkbox"/> NA <input type="checkbox"/>	NA	
10.7.8	Verification from Land revenue department	Yes <input type="checkbox"/> No <input type="checkbox"/> NA <input type="checkbox"/>	NA	
10.7.9	Verification by CALA office	Yes <input type="checkbox"/> No <input type="checkbox"/> NA <input type="checkbox"/>	NA	

### 1.1.1 DPR Checklist - Stage 7 - Award determination (Pavements)

General Details	
Project Name	
Consultant's Name	
Date of Review	

S.No	SECTION OF THE REPORT	YES/NO/NA	Details/ Specifications	Remarks
1	<b>Executive Summary</b>	Yes <input type="checkbox"/> No <input type="checkbox"/> NA <input type="checkbox"/>	NA	
2	<b>Village level summary</b>	Yes <input type="checkbox"/> No <input type="checkbox"/> NA <input type="checkbox"/>	NA	
2.1	Total private and public land being acquired	Yes <input type="checkbox"/> No <input type="checkbox"/> NA <input type="checkbox"/>	NA	
2.2	Variation in area and nature of land against 3D with justification	Yes <input type="checkbox"/> No <input type="checkbox"/> NA <input type="checkbox"/>	NA	
2.3	Method used by CALA to arrive at award	Yes <input type="checkbox"/> No <input type="checkbox"/> NA <input type="checkbox"/>	NA	
2.4	Date of award by CALA and approval by NHAI along with valuation report			
2.5	Total award calculated and deviation from RFCTLARR act	Yes <input type="checkbox"/> No <input type="checkbox"/> NA <input type="checkbox"/>	NA	
3	<b>In detail for each Village</b>	Yes <input type="checkbox"/> No <input type="checkbox"/> NA <input type="checkbox"/>	NA	
3.1	Updated land acquisition tracker with status of: <ul style="list-style-type: none"> <li>• Notifications</li> <li>• Award</li> <li>• Disbursement</li> </ul>	Yes <input type="checkbox"/> No <input type="checkbox"/> NA <input type="checkbox"/>	NA	
3.2	Valuation report and details of award calculation- verification by state authority to be included	Yes <input type="checkbox"/> No <input type="checkbox"/> NA <input type="checkbox"/>	NA	
3.3	Claims report	Yes <input type="checkbox"/> No <input type="checkbox"/> NA <input type="checkbox"/>	NA	
3.4	Copies of notifications published	Yes <input type="checkbox"/> No <input type="checkbox"/> NA <input type="checkbox"/>	NA	
3.5	Copies of land possession certificates received	Yes <input type="checkbox"/> No <input type="checkbox"/> NA <input type="checkbox"/>	NA	
4	<b>Conclusions and recommendations</b>	Yes <input type="checkbox"/> No <input type="checkbox"/> NA <input type="checkbox"/>	NA	
4.1	Conclusions and recommendations	Yes <input type="checkbox"/> No <input type="checkbox"/> NA <input type="checkbox"/>	NA	
4.2	Report fulfils project objectives and scope as per RFP	Yes <input type="checkbox"/> No <input type="checkbox"/> NA <input type="checkbox"/>	NA	
4.3	Report reviewed for errors and omissions	Yes <input type="checkbox"/> No <input type="checkbox"/> NA <input type="checkbox"/>	NA	
4.4	Compliance report prepared on client observations	Yes <input type="checkbox"/> No <input type="checkbox"/> NA <input type="checkbox"/>	NA	

## 1.1.2 DPR Checklist - Stage 8 - Land possession report (Pavements)

General Details	
Project Name	
Consultant's Name	
Date of Review	

S.No	SECTION OF THE REPORT	YES/NO/NA	Details/ Specifications	Remarks
1	<b>Executive Summary</b>	Yes <input type="checkbox"/> No <input type="checkbox"/> NA <input type="checkbox"/>	NA	
2	<b>Village level summary</b>	Yes <input type="checkbox"/> No <input type="checkbox"/> NA <input type="checkbox"/>	NA	
2.1	Total private and public land being acquired	Yes <input type="checkbox"/> No <input type="checkbox"/> NA <input type="checkbox"/>	NA	
2.2	Date of final award by CALA and approval by NHA			
2.3	Status of disbursement on date of receipt of Land possession certificate	Yes <input type="checkbox"/> No <input type="checkbox"/> NA <input type="checkbox"/>	NA	
2.4	Key issues being faced in completing land acquisition, if any	Yes <input type="checkbox"/> No <input type="checkbox"/> NA <input type="checkbox"/>	NA	
3	<b>In detail for each Village</b>	Yes <input type="checkbox"/> No <input type="checkbox"/> NA <input type="checkbox"/>	NA	
3.1	Updated land acquisition tracker with status of: <ul style="list-style-type: none"> <li>• Notifications</li> <li>• Award</li> <li>• Disbursement</li> </ul>	Yes <input type="checkbox"/> No <input type="checkbox"/> NA <input type="checkbox"/>	NA	
3.2	Final award and claims report	Yes <input type="checkbox"/> No <input type="checkbox"/> NA <input type="checkbox"/>	NA	
3.3	Copies of notifications published, land possession certificates received	Yes <input type="checkbox"/> No <input type="checkbox"/> NA <input type="checkbox"/>	NA	
4	<b>Conclusions and recommendations</b>	Yes <input type="checkbox"/> No <input type="checkbox"/> NA <input type="checkbox"/>	NA	
4.1	Conclusions and recommendations	Yes <input type="checkbox"/> No <input type="checkbox"/> NA <input type="checkbox"/>	NA	
4.2	Report fulfils project objectives and scope as per RFP	Yes <input type="checkbox"/> No <input type="checkbox"/> NA <input type="checkbox"/>	NA	
4.3	Report reviewed for errors and omissions	Yes <input type="checkbox"/> No <input type="checkbox"/> NA <input type="checkbox"/>	NA	
4.4	Compliance report prepared on client observations	Yes <input type="checkbox"/> No <input type="checkbox"/> NA <input type="checkbox"/>	NA	
5	<b>GIS Map containing digitised details of land parcels acquired with all relevant details</b>	Yes <input type="checkbox"/> No <input type="checkbox"/> NA <input type="checkbox"/>	NA	



## Annexure III: Checklists for Structures such as ROB/ RUB

### DPR Checklist - Stage 1 - Inception Report (Structures)

General Details	
Project Name	
Consultant's Name	
Date of Review	

S.No	SECTION OF THE REPORT	YES/NO/NA	Details/ Specifications	Remarks
1	<b>Executive Summary</b>	Yes <input type="checkbox"/> No <input type="checkbox"/> NA <input type="checkbox"/>	NA	
2	<b>Project Appreciation</b>	Yes <input type="checkbox"/> No <input type="checkbox"/> NA <input type="checkbox"/>	NA	
2.1	Location of site office	Yes <input type="checkbox"/> No <input type="checkbox"/> NA <input type="checkbox"/>		
2.2	Review of scope of ToR and gap identification	Yes <input type="checkbox"/> No <input type="checkbox"/> NA <input type="checkbox"/>	NA	
2.3	Details of key departments for documents	Yes <input type="checkbox"/> No <input type="checkbox"/> NA <input type="checkbox"/>		
2.4	Project description <ul style="list-style-type: none"> <li>• Existing LC number</li> <li>• Start and End Chainage</li> <li>• Village/District</li> </ul>	Yes <input type="checkbox"/> No <input type="checkbox"/> NA <input type="checkbox"/>		
2.5	Project location map <ul style="list-style-type: none"> <li>• On State Map</li> <li>• On District Map</li> <li>• Latitude &amp; Longitude Coordinates of the LC</li> </ul>	Yes <input type="checkbox"/> No <input type="checkbox"/> NA <input type="checkbox"/>		
2.6	Details of Existing Level Crossing <ul style="list-style-type: none"> <li>• Number of Railway Tracks</li> <li>• Type of Railway Tracks (Broad/Metre/Narrow)</li> <li>• No. of trains per day</li> </ul>	Yes <input type="checkbox"/> No <input type="checkbox"/> NA <input type="checkbox"/>		
2.7	Justification for need of an ROB/RUB (on basis of TVU count)	Yes <input type="checkbox"/> No <input type="checkbox"/> NA <input type="checkbox"/>	NA	
2.8	Overview of land use plans	Yes <input type="checkbox"/> No <input type="checkbox"/> NA <input type="checkbox"/>	NA	
2.9	Overview of existing pavement conditions <ul style="list-style-type: none"> <li>• Number of Lanes</li> <li>• Type of Pavement (Flexible/Rigid/Surfaced/Unsurfaced)</li> </ul>	Yes <input type="checkbox"/> No <input type="checkbox"/> NA <input type="checkbox"/>		
2.10	Existing right of way details	Yes <input type="checkbox"/> No <input type="checkbox"/> NA <input type="checkbox"/>		
2.11	Any other details relevant to the project	Yes <input type="checkbox"/> No <input type="checkbox"/> NA <input type="checkbox"/>	NA	
3	<b>Approach Methodology</b>	Yes <input type="checkbox"/> No <input type="checkbox"/> NA <input type="checkbox"/>	NA	
3.1	Engineering survey and investigations	Yes <input type="checkbox"/> No <input type="checkbox"/> NA <input type="checkbox"/>	NA	
3.2	Design of road, pavements and structures	Yes <input type="checkbox"/> No <input type="checkbox"/> NA <input type="checkbox"/>	NA	
3.3	Environment and social impact assessment	Yes <input type="checkbox"/> No <input type="checkbox"/> NA <input type="checkbox"/>	NA	

S.No	SECTION OF THE REPORT	YES/NO/NA	Details/ Specifications	Remarks
3.4	Estimation of project cost, viability and financing options	Yes <input type="checkbox"/> No <input type="checkbox"/> NA <input type="checkbox"/>	NA	
3.5	Any other details relevant to the project	Yes <input type="checkbox"/> No <input type="checkbox"/> NA <input type="checkbox"/>	NA	
4	<b>Task Assignment and Manning Schedule</b>	Yes <input type="checkbox"/> No <input type="checkbox"/> NA <input type="checkbox"/>	NA	
4.1	Number of key personnel provided	Yes <input type="checkbox"/> No <input type="checkbox"/> NA <input type="checkbox"/>		
4.2	Specific tasks assigned to each key personnel	Yes <input type="checkbox"/> No <input type="checkbox"/> NA <input type="checkbox"/>	NA	
4.3	Manning schedule for key personnel	Yes <input type="checkbox"/> No <input type="checkbox"/> NA <input type="checkbox"/>	NA	
4.4	Number of key personnel deployed at site	Yes <input type="checkbox"/> No <input type="checkbox"/> NA <input type="checkbox"/>		
5	<b>Performa for data collection</b>	Yes <input type="checkbox"/> No <input type="checkbox"/> NA <input type="checkbox"/>	NA	
6	<b>Indicative Design standards and cross sections</b>	Yes <input type="checkbox"/> No <input type="checkbox"/> NA <input type="checkbox"/>	NA	
7	<b>Development plans</b>	Yes <input type="checkbox"/> No <input type="checkbox"/> NA <input type="checkbox"/>	NA	
7.1	Overview of development plans being implemented/ proposed by local bodies	Yes <input type="checkbox"/> No <input type="checkbox"/> NA <input type="checkbox"/>	NA	
7.2	Overview of impact of such development plans	Yes <input type="checkbox"/> No <input type="checkbox"/> NA <input type="checkbox"/>	NA	
8	<b>Quality Assurance Plan</b>	Yes <input type="checkbox"/> No <input type="checkbox"/> NA <input type="checkbox"/>	NA	
8.1	Engineering surveys and investigation	Yes <input type="checkbox"/> No <input type="checkbox"/> NA <input type="checkbox"/>	NA	
8.2	Traffic surveys	Yes <input type="checkbox"/> No <input type="checkbox"/> NA <input type="checkbox"/>	NA	
8.3	Material geo-technical and sub-soil investigations	Yes <input type="checkbox"/> No <input type="checkbox"/> NA <input type="checkbox"/>	NA	
8.4	Road and pavement investigations	Yes <input type="checkbox"/> No <input type="checkbox"/> NA <input type="checkbox"/>	NA	
8.5	Investigation and design of bridges and structures	Yes <input type="checkbox"/> No <input type="checkbox"/> NA <input type="checkbox"/>	NA	
8.6	Environment and R&R assessment	Yes <input type="checkbox"/> No <input type="checkbox"/> NA <input type="checkbox"/>	NA	
8.7	Economic and financial analysis	Yes <input type="checkbox"/> No <input type="checkbox"/> NA <input type="checkbox"/>	NA	
8.8	Drawing and documentation	Yes <input type="checkbox"/> No <input type="checkbox"/> NA <input type="checkbox"/>	NA	
8.9	Discussion of draft QAP document with client	Yes <input type="checkbox"/> No <input type="checkbox"/> NA <input type="checkbox"/>	NA	
8.10	Approval of final QAP document by client	Yes <input type="checkbox"/> No <input type="checkbox"/> NA <input type="checkbox"/>	NA	
8.11	Any other details relevant to the project	Yes <input type="checkbox"/> No <input type="checkbox"/> NA <input type="checkbox"/>	NA	
9	<b>Draft design standards</b>	Yes <input type="checkbox"/> No <input type="checkbox"/> NA <input type="checkbox"/>	NA	
9.1	Geometric design standards of bridges (Plain)	Yes <input type="checkbox"/> No <input type="checkbox"/> NA <input type="checkbox"/>	NA	
9.2	Geometric design standards of bridges (Hilly)	Yes <input type="checkbox"/> No <input type="checkbox"/> NA <input type="checkbox"/>	NA	
9.3	Any other details relevant to the project	Yes <input type="checkbox"/> No <input type="checkbox"/> NA <input type="checkbox"/>	NA	
10	<b>Conclusions and recommendations</b>	Yes <input type="checkbox"/> No <input type="checkbox"/> NA <input type="checkbox"/>	NA	
10.1	Conclusions and recommendations	Yes <input type="checkbox"/> No <input type="checkbox"/> NA <input type="checkbox"/>	NA	
10.2	Report fulfils project objectives and scope as per RFP	Yes <input type="checkbox"/> No <input type="checkbox"/> NA <input type="checkbox"/>	NA	
10.3	Report reviewed for errors and omissions	Yes <input type="checkbox"/> No <input type="checkbox"/> NA <input type="checkbox"/>	NA	

S.No	SECTION OF THE REPORT	YES/NO/NA	Details/ Specifications	Remarks
10.4	Compliance report prepared on client observations	Yes <input type="checkbox"/> No <input type="checkbox"/> NA <input type="checkbox"/>	NA	

## DPR Checklist - Stage 2 - Feasibility Report (Structures)

General Details	
Project Name	
Consultant's Name	
Date of Review	

S.No	SECTION OF THE REPORT	YES/NO/NA	Details/ Specifications	Remarks
1	<b>Executive Summary</b>	Yes <input type="checkbox"/> No <input type="checkbox"/> NA <input type="checkbox"/>	NA	
2	<b>Overview of client organization / activities</b>	Yes <input type="checkbox"/> No <input type="checkbox"/> NA <input type="checkbox"/>	NA	
3	<b>Methodology adopted for feasibility study</b>	Yes <input type="checkbox"/> No <input type="checkbox"/> NA <input type="checkbox"/>	NA	
4	<b>Socioeconomic profile of the project areas</b>	Yes <input type="checkbox"/> No <input type="checkbox"/> NA <input type="checkbox"/>	NA	
4.1	Regional economic profile basis last 10 years data as per IRC	Yes <input type="checkbox"/> No <input type="checkbox"/> NA <input type="checkbox"/>	NA	
4.2	Economic profile of project influence area basis last 10 years data as per IRC	Yes <input type="checkbox"/> No <input type="checkbox"/> NA <input type="checkbox"/>	NA	
4.3	Socio Economic status of project influence area	Yes <input type="checkbox"/> No <input type="checkbox"/> NA <input type="checkbox"/>	NA	
5	<b>Indicative design standards, methodologies, and specifications</b>	Yes <input type="checkbox"/> No <input type="checkbox"/> NA <input type="checkbox"/>	NA	
6	<b>Traffic surveys and analysis</b>	Yes <input type="checkbox"/> No <input type="checkbox"/> NA <input type="checkbox"/>	NA	
6.1	Classified traffic volume counts using IHMCL data (7 day)	Yes <input type="checkbox"/> No <input type="checkbox"/> NA <input type="checkbox"/>	NA	
6.2	Traffic projection methodology as per IRC:108	Yes <input type="checkbox"/> No <input type="checkbox"/> NA <input type="checkbox"/>	NA	
6.3	Projected Traffic data for 20 years	Yes <input type="checkbox"/> No <input type="checkbox"/> NA <input type="checkbox"/>	NA	
6.4	Current and Projected PCU	Yes <input type="checkbox"/> No <input type="checkbox"/> NA <input type="checkbox"/>		
6.5	Current and Projected TVU	Yes <input type="checkbox"/> No <input type="checkbox"/> NA <input type="checkbox"/>		
6.6	Axle load survey as per IRC:SP:19	Yes <input type="checkbox"/> No <input type="checkbox"/> NA <input type="checkbox"/>	NA	
6.7	Any other details relevant to the project	Yes <input type="checkbox"/> No <input type="checkbox"/> NA <input type="checkbox"/>	NA	
6.8	Traffic surveys monitored and reviewed by the client	Yes <input type="checkbox"/> No <input type="checkbox"/> NA <input type="checkbox"/>	NA	
7	<b>Reconnaissance survey</b>	Yes <input type="checkbox"/> No <input type="checkbox"/> NA <input type="checkbox"/>	NA	
7.1	Road Inventory as per IRC:SP:19	Yes <input type="checkbox"/> No <input type="checkbox"/> NA <input type="checkbox"/>	NA	
7.2	Review of Road Inventory Survey by client	Yes <input type="checkbox"/> No <input type="checkbox"/> NA <input type="checkbox"/>	NA	
7.3	Geometric Features of the Existing Road <ul style="list-style-type: none"> <li>• Design Speed</li> <li>• Sight distance elements</li> <li>• Horizontal Alignment Details</li> <li>• Vertical Alignment Details</li> <li>• Height of Embankment</li> </ul>	Yes <input type="checkbox"/> No <input type="checkbox"/> NA <input type="checkbox"/>	NA	
7.4	Topographical Survey as per IRC:SP:19 using LiDAR or equivalent technology <ul style="list-style-type: none"> <li>• Gradient</li> <li>• Terrain</li> </ul>	Yes <input type="checkbox"/> No <input type="checkbox"/> NA <input type="checkbox"/>	NA	
7.5	Review of topographical survey by client	Yes <input type="checkbox"/> No <input type="checkbox"/> NA <input type="checkbox"/>	NA	

S.No	SECTION OF THE REPORT	YES/NO/NA	Details/ Specifications	Remarks
7.6	Pavement composition and condition survey as per IRC:SP:19	Yes <input type="checkbox"/> No <input type="checkbox"/> NA <input type="checkbox"/>	NA	
7.7	Geological Survey <ul style="list-style-type: none"> <li>Geological Map of the Area</li> <li>Seismicity</li> </ul>	Yes <input type="checkbox"/> No <input type="checkbox"/> NA <input type="checkbox"/>	NA	
7.8	Climatic Conditions <ul style="list-style-type: none"> <li>Temperature</li> <li>Rainfall</li> <li>Wind</li> </ul>	Yes <input type="checkbox"/> No <input type="checkbox"/> NA <input type="checkbox"/>	NA	
7.9	Land Use along the existing alignment <ul style="list-style-type: none"> <li>Map of the Project Area depicting Agricultural/Habitation/Forest Area</li> </ul>	Yes <input type="checkbox"/> No <input type="checkbox"/> NA <input type="checkbox"/>	NA	
7.10	Details of Existing Structures <ul style="list-style-type: none"> <li>Map of the Project Area depicting Hutments/Buildings/Temples/Public Building/Any Other Significant Structure</li> </ul>	Yes <input type="checkbox"/> No <input type="checkbox"/> NA <input type="checkbox"/>	NA	
7.11	Inventory and condition survey of culverts	Yes <input type="checkbox"/> No <input type="checkbox"/> NA <input type="checkbox"/>	NA	
7.12	Any other details relevant to the project	Yes <input type="checkbox"/> No <input type="checkbox"/> NA <input type="checkbox"/>	NA	
8	<b>Geotechnical Survey</b>	Yes <input type="checkbox"/> No <input type="checkbox"/> NA <input type="checkbox"/>	NA	
8.1	Geo-technical and sub-soil explorations as per IRC:78	Yes <input type="checkbox"/> No <input type="checkbox"/> NA <input type="checkbox"/>	NA	
8.2	Number of Bore holes dug (holds for every pier and abutment)	Yes <input type="checkbox"/> No <input type="checkbox"/> NA <input type="checkbox"/>		
8.3	Review of geo-technical and sub-soil explorations by client	Yes <input type="checkbox"/> No <input type="checkbox"/> NA <input type="checkbox"/>	NA	
8.4	Field testing, soil sampling, laboratory testing as per IRC:78	Yes <input type="checkbox"/> No <input type="checkbox"/> NA <input type="checkbox"/>	NA	
8.5	Recommendation of Foundation Type and Depth	Yes <input type="checkbox"/> No <input type="checkbox"/> NA <input type="checkbox"/>		
8.6	Any other details relevant to the project	Yes <input type="checkbox"/> No <input type="checkbox"/> NA <input type="checkbox"/>	NA	
9	<b>Hydraulic &amp; Hydrological Survey</b>	Yes <input type="checkbox"/> No <input type="checkbox"/> NA <input type="checkbox"/>	NA	
9.1	Hydrological investigations as per IRC:5 and IRC: 13	Yes <input type="checkbox"/> No <input type="checkbox"/> NA <input type="checkbox"/>	NA	
9.2	High Flood Level specified	Yes <input type="checkbox"/> No <input type="checkbox"/> NA <input type="checkbox"/>	NA	
9.3	Depth of Water Table specified	Yes <input type="checkbox"/> No <input type="checkbox"/> NA <input type="checkbox"/>	NA	
9.4	Ponded Water Level specified	Yes <input type="checkbox"/> No <input type="checkbox"/> NA <input type="checkbox"/>	NA	
9.5	Any other details relevant to the project	Yes <input type="checkbox"/> No <input type="checkbox"/> NA <input type="checkbox"/>	NA	
9.6	Review of Hydrological Survey by the client	Yes <input type="checkbox"/> No <input type="checkbox"/> NA <input type="checkbox"/>	NA	
10	<b>Materials Survey</b>	Yes <input type="checkbox"/> No <input type="checkbox"/> NA <input type="checkbox"/>	NA	
10.1	Materials Survey conducted as per IRC:SP:19	Yes <input type="checkbox"/> No <input type="checkbox"/> NA <input type="checkbox"/>	NA	
10.2	Sources of Naturally Occurring Aggregates specified <ul style="list-style-type: none"> <li>Details of Borrow Pits with Distance from Project Site</li> <li>Cost of Material/Transportation</li> </ul>	Yes <input type="checkbox"/> No <input type="checkbox"/> NA <input type="checkbox"/>		

S.No	SECTION OF THE REPORT	YES/NO/NA	Details/ Specifications	Remarks
10.3	Sources of Manufactured Items specified <ul style="list-style-type: none"> <li>• Details of Suppliers with Distance from Project Site</li> <li>• Cost of Material/Transportation</li> </ul>	Yes <input type="checkbox"/> No <input type="checkbox"/> NA <input type="checkbox"/>	NA	
10.4	Source of Water for construction specified as per IS:456	Yes <input type="checkbox"/> No <input type="checkbox"/> NA <input type="checkbox"/>	NA	
10.5	Any other details relevant to the project	Yes <input type="checkbox"/> No <input type="checkbox"/> NA <input type="checkbox"/>	NA	
11	<b>Determination of whether ROB or RUB is appropriate</b>	Yes <input type="checkbox"/> No <input type="checkbox"/> NA <input type="checkbox"/>	NA	
11.1	Justification of whether ROB or RUB should be built	Yes <input type="checkbox"/> No <input type="checkbox"/> NA <input type="checkbox"/>	NA	
11.2	Review of justification by client	Yes <input type="checkbox"/> No <input type="checkbox"/> NA <input type="checkbox"/>	NA	
12	<b>Alignment Options Study</b>	Yes <input type="checkbox"/> No <input type="checkbox"/> NA <input type="checkbox"/>	NA	
12.1	At least two alignments proposed <ul style="list-style-type: none"> <li>• Details of Alignments on Map</li> </ul>	Yes <input type="checkbox"/> No <input type="checkbox"/> NA <input type="checkbox"/>	NA	
12.2	Review of options with client	Yes <input type="checkbox"/> No <input type="checkbox"/> NA <input type="checkbox"/>	NA	
12.2.1	Review of options with local authority	Yes <input type="checkbox"/> No <input type="checkbox"/> NA <input type="checkbox"/>	NA	
12.3	Length of the project along proposed alignment options	Yes <input type="checkbox"/> No <input type="checkbox"/> NA <input type="checkbox"/>	NA	
12.4	Land Acquisition required along alignment options	Yes <input type="checkbox"/> No <input type="checkbox"/> NA <input type="checkbox"/>	NA	
12.5	Cost Estimates of alternatives	Yes <input type="checkbox"/> No <input type="checkbox"/> NA <input type="checkbox"/>	NA	
12.6	Recommended Alignment with Justification	Yes <input type="checkbox"/> No <input type="checkbox"/> NA <input type="checkbox"/>		
12.7	Skew Angle of Proposed Alignment Specified	Yes <input type="checkbox"/> No <input type="checkbox"/> NA <input type="checkbox"/>		
12.7.1	Environmental impact of each option	Yes <input type="checkbox"/> No <input type="checkbox"/> NA <input type="checkbox"/>		
12.7.2	Review of road geometry and safety for each option	Yes <input type="checkbox"/> No <input type="checkbox"/> NA <input type="checkbox"/>	NA	
12.9	Traffic Diversion Route Specified	Yes <input type="checkbox"/> No <input type="checkbox"/> NA <input type="checkbox"/>	NA	
12.10	Any other details relevant to the project	Yes <input type="checkbox"/> No <input type="checkbox"/> NA <input type="checkbox"/>	NA	
13	<b>Environmental screening/ preliminary environmental assessment</b>	Yes <input type="checkbox"/> No <input type="checkbox"/> NA <input type="checkbox"/>	NA	
13.1	Analysis basis Initial Environment Examination in IRC: SP: 19	Yes <input type="checkbox"/> No <input type="checkbox"/> NA <input type="checkbox"/>	NA	
13.2	Recommended feasible mitigation measures	Yes <input type="checkbox"/> No <input type="checkbox"/> NA <input type="checkbox"/>	NA	
14	<b>Initial social assessment/ preliminary LA resettlement plan</b>	Yes <input type="checkbox"/> No <input type="checkbox"/> NA <input type="checkbox"/>	NA	
14.1	Analysis basis Initial Environment Examination in IRC: SP: 19	Yes <input type="checkbox"/> No <input type="checkbox"/> NA <input type="checkbox"/>	NA	
14.2	Details of consultation with potentially affected persons	Yes <input type="checkbox"/> No <input type="checkbox"/> NA <input type="checkbox"/>	NA	
14.3	Details of consultation with local NGOs	Yes <input type="checkbox"/> No <input type="checkbox"/> NA <input type="checkbox"/>	NA	
14.4	Details of consultation with municipal authorities	Yes <input type="checkbox"/> No <input type="checkbox"/> NA <input type="checkbox"/>	NA	
14.5	Preliminary resettlement plan	Yes <input type="checkbox"/> No <input type="checkbox"/> NA <input type="checkbox"/>	NA	
14.6	Any other details relevant to the project	Yes <input type="checkbox"/> No <input type="checkbox"/> NA <input type="checkbox"/>	NA	

S.No	SECTION OF THE REPORT	YES/NO/NA	Details/ Specifications	Remarks
15	<b>Cost estimates</b>	Yes <input type="checkbox"/> No <input type="checkbox"/> NA <input type="checkbox"/>	NA	
15.1	Item rates and rate analysis	Yes <input type="checkbox"/> No <input type="checkbox"/> NA <input type="checkbox"/>	NA	
15.2	Escalation	Yes <input type="checkbox"/> No <input type="checkbox"/> NA <input type="checkbox"/>	NA	
16	<b>Economic and financial analysis</b>	Yes <input type="checkbox"/> No <input type="checkbox"/> NA <input type="checkbox"/>	NA	
16.1	Estimated cost details	Yes <input type="checkbox"/> No <input type="checkbox"/> NA <input type="checkbox"/>	NA	
16.2	Projected revenues details	Yes <input type="checkbox"/> No <input type="checkbox"/> NA <input type="checkbox"/>	NA	
16.3	Assumptions stated	Yes <input type="checkbox"/> No <input type="checkbox"/> NA <input type="checkbox"/>	NA	
16.4	Analysis and results <ul style="list-style-type: none"> <li>• IRR</li> <li>• Sensitivity Analysis</li> <li>• Financial Viability</li> </ul>	Yes <input type="checkbox"/> No <input type="checkbox"/> NA <input type="checkbox"/>	NA	
16.5	Any other details relevant to the project	Yes <input type="checkbox"/> No <input type="checkbox"/> NA <input type="checkbox"/>	NA	
17	<b>Strip Plan</b>		NA	
17.1	Details of center line of proposed structure	Yes <input type="checkbox"/> No <input type="checkbox"/> NA <input type="checkbox"/>	NA	
17.2	Details of existing RoW	Yes <input type="checkbox"/> No <input type="checkbox"/> NA <input type="checkbox"/>		
17.3	Details of proposed RoW	Yes <input type="checkbox"/> No <input type="checkbox"/> NA <input type="checkbox"/>		
17.4	Details about ownership of land to be acquired	Yes <input type="checkbox"/> No <input type="checkbox"/> NA <input type="checkbox"/>	NA	
17.5	Strip plan basis reconnaissance and topographic surveys	Yes <input type="checkbox"/> No <input type="checkbox"/> NA <input type="checkbox"/>	NA	
17.6	Strip plan reviewed and approved by the client	Yes <input type="checkbox"/> No <input type="checkbox"/> NA <input type="checkbox"/>	NA	
17.7	Any other details relevant to the project	Yes <input type="checkbox"/> No <input type="checkbox"/> NA <input type="checkbox"/>	NA	
11	<b>Strip plan- additional details added</b>	Yes <input type="checkbox"/> No <input type="checkbox"/> NA <input type="checkbox"/>	NA	
11.1	Details of centreline, existing structures, road furniture and other features	Yes <input type="checkbox"/> No <input type="checkbox"/> NA <input type="checkbox"/>	NA	
11.2	Widening scheme	Yes <input type="checkbox"/> No <input type="checkbox"/> NA <input type="checkbox"/>	NA	
11.3	New construction/ reconstruction of structures and amenities	Yes <input type="checkbox"/> No <input type="checkbox"/> NA <input type="checkbox"/>	NA	
11.4	Existing and proposed right of way	Yes <input type="checkbox"/> No <input type="checkbox"/> NA <input type="checkbox"/>	NA	
11.5	Clearances impacting each chainage	Yes <input type="checkbox"/> No <input type="checkbox"/> NA <input type="checkbox"/>	NA	

## DPR Checklist - Stage 3 - LA and Clearances I Report (Structures)

General Details	
Project Name	
Consultant's Name	
Date of Review	

S.No	SECTION OF THE REPORT	YES/NO/NA	Details/ Specifications	Remarks
1	<b>Executive Summary</b>	Yes <input type="checkbox"/> No <input type="checkbox"/> NA <input type="checkbox"/>	NA	
2	<b>Environment Clearance</b>	Yes <input type="checkbox"/> No <input type="checkbox"/> NA <input type="checkbox"/>	NA	
2.1	Requirement for environment clearance identified	Yes <input type="checkbox"/> No <input type="checkbox"/> NA <input type="checkbox"/>	NA	
2.2	Date/ Details of Initial consultation with competent authority	Yes <input type="checkbox"/> No <input type="checkbox"/> NA <input type="checkbox"/>		
2.3	Date of submission of draft EIA report/ proposal for clearance	Yes <input type="checkbox"/> No <input type="checkbox"/> NA <input type="checkbox"/>	NA	
2.4	Review of proposal/ EIA report by client	Yes <input type="checkbox"/> No <input type="checkbox"/> NA <input type="checkbox"/>	NA	
3	<b>Forest Clearance</b>	Yes <input type="checkbox"/> No <input type="checkbox"/> NA <input type="checkbox"/>	NA	
3.1	Requirement for forest clearance identified	Yes <input type="checkbox"/> No <input type="checkbox"/> NA <input type="checkbox"/>	NA	
3.2	Date/ Details of initial consultation with competent authority	Yes <input type="checkbox"/> No <input type="checkbox"/> NA <input type="checkbox"/>		
3.3	Details/cost of trees being felled basis concerned District Forest Office	Yes <input type="checkbox"/> No <input type="checkbox"/> NA <input type="checkbox"/>		
3.4	Date of submission of proposal for forest clearance	Yes <input type="checkbox"/> No <input type="checkbox"/> NA <input type="checkbox"/>	NA	
3.5	Review of proposal by client	Yes <input type="checkbox"/> No <input type="checkbox"/> NA <input type="checkbox"/>	NA	
4	<b>Wildlife Clearance</b>	Yes <input type="checkbox"/> No <input type="checkbox"/> NA <input type="checkbox"/>	NA	
4.1	Requirement for wildlife clearance identified	Yes <input type="checkbox"/> No <input type="checkbox"/> NA <input type="checkbox"/>	NA	
4.2	Date/ Details of initial consultation with competent authority	Yes <input type="checkbox"/> No <input type="checkbox"/> NA <input type="checkbox"/>		
4.3	Details/cost of trees being felled basis concerned District Forest Office	Yes <input type="checkbox"/> No <input type="checkbox"/> NA <input type="checkbox"/>		
4.4	Date of submission of proposal for wildlife clearance	Yes <input type="checkbox"/> No <input type="checkbox"/> NA <input type="checkbox"/>		
4.5	Review of proposal by client	Yes <input type="checkbox"/> No <input type="checkbox"/> NA <input type="checkbox"/>	NA	
5	<b>Utility Clearances (Electricity)</b>	Yes <input type="checkbox"/> No <input type="checkbox"/> NA <input type="checkbox"/>	NA	
5.1	Identification of overground utilities	Yes <input type="checkbox"/> No <input type="checkbox"/> NA <input type="checkbox"/>	NA	
5.2	Identification of underground utilities using GPR, Induction Locator or equivalent technologies	Yes <input type="checkbox"/> No <input type="checkbox"/> NA <input type="checkbox"/>	NA	
5.3	Name/ Details of consultation with local authority/ people	Yes <input type="checkbox"/> No <input type="checkbox"/> NA <input type="checkbox"/>		
5.4	Utility relocation plan with existing / proposed location showing existing RoW and topographic details	Yes <input type="checkbox"/> No <input type="checkbox"/> NA <input type="checkbox"/>	NA	
5.5	Cost for relocation as per authority	Yes <input type="checkbox"/> No <input type="checkbox"/> NA <input type="checkbox"/>		



S.No	SECTION OF THE REPORT	YES/NO/NA	Details/ Specifications	Remarks
5.6	Date of proposal submission to competent authority	Yes <input type="checkbox"/> No <input type="checkbox"/> NA <input type="checkbox"/>		
5.7	Review of utility relocation plan/ proposal by client	Yes <input type="checkbox"/> No <input type="checkbox"/> NA <input type="checkbox"/>	NA	
6	<b>Utility Clearances (Water)</b>	Yes <input type="checkbox"/> No <input type="checkbox"/> NA <input type="checkbox"/>	NA	
6.1	Identification of overground utilities in RoW	Yes <input type="checkbox"/> No <input type="checkbox"/> NA <input type="checkbox"/>	NA	
6.2	Identification of underground utilities using GPR, Induction Locator or equivalent technologies	Yes <input type="checkbox"/> No <input type="checkbox"/> NA <input type="checkbox"/>	NA	
6.3	Name/ Details of consultation with local authority/ people	Yes <input type="checkbox"/> No <input type="checkbox"/> NA <input type="checkbox"/>		
6.4	Utility relocation plan with existing / proposed location showing existing RoW and topographic details	Yes <input type="checkbox"/> No <input type="checkbox"/> NA <input type="checkbox"/>	NA	
6.5	Cost for relocation as per authority	Yes <input type="checkbox"/> No <input type="checkbox"/> NA <input type="checkbox"/>		
6.6	Date of proposal submission to competent authority	Yes <input type="checkbox"/> No <input type="checkbox"/> NA <input type="checkbox"/>	NA	
6.7	Review of utility relocation plan/ proposal by client	Yes <input type="checkbox"/> No <input type="checkbox"/> NA <input type="checkbox"/>	NA	
7	<b>Utility Clearances (Others)</b>	Yes <input type="checkbox"/> No <input type="checkbox"/> NA <input type="checkbox"/>	NA	
7.1	Identification of over ground utilities in RoW	Yes <input type="checkbox"/> No <input type="checkbox"/> NA <input type="checkbox"/>	NA	
7.2	Identification of underground utilities using GPR, Induction Locator or equivalent technologies	Yes <input type="checkbox"/> No <input type="checkbox"/> NA <input type="checkbox"/>	NA	
7.3	Name/ Details of consultation with local authority/ people	Yes <input type="checkbox"/> No <input type="checkbox"/> NA <input type="checkbox"/>		
7.4	Utility relocation plan with existing / proposed location showing existing RoW and topographic details	Yes <input type="checkbox"/> No <input type="checkbox"/> NA <input type="checkbox"/>	NA	
7.5	Cost for relocation as per authority	Yes <input type="checkbox"/> No <input type="checkbox"/> NA <input type="checkbox"/>		
7.6	Date of proposal submission to competent authority	Yes <input type="checkbox"/> No <input type="checkbox"/> NA <input type="checkbox"/>		
7.7	Review of utility relocation plan/ proposal by client	Yes <input type="checkbox"/> No <input type="checkbox"/> NA <input type="checkbox"/>	NA	
8	<b>Railway Clearances</b>	Yes <input type="checkbox"/> No <input type="checkbox"/> NA <input type="checkbox"/>	NA	
8.1	Identification of ROB/ RUB on project corridor	Yes <input type="checkbox"/> No <input type="checkbox"/> NA <input type="checkbox"/>	NA	
8.2	Initial consultation with competent authority	Yes <input type="checkbox"/> No <input type="checkbox"/> NA <input type="checkbox"/>	NA	
8.3	Date of proposal submission to competent authority	Yes <input type="checkbox"/> No <input type="checkbox"/> NA <input type="checkbox"/>		
8.4	Review of GAD/ proposal by client	Yes <input type="checkbox"/> No <input type="checkbox"/> NA <input type="checkbox"/>	NA	
9	<b>Other Clearances</b>	Yes <input type="checkbox"/> No <input type="checkbox"/> NA <input type="checkbox"/>	NA	
9.1	Requirement for other clearances identified	Yes <input type="checkbox"/> No <input type="checkbox"/> NA <input type="checkbox"/>	NA	
9.2	Date of proposal submission to competent authority	Yes <input type="checkbox"/> No <input type="checkbox"/> NA <input type="checkbox"/>		
9.3	Review of proposal by client	Yes <input type="checkbox"/> No <input type="checkbox"/> NA <input type="checkbox"/>	NA	
10	<b>Land Acquisition</b>	Yes <input type="checkbox"/> No <input type="checkbox"/> NA <input type="checkbox"/>	NA	

S.No	SECTION OF THE REPORT	YES/NO/NA	Details/ Specifications	Remarks
10.1	Detailed schedule about acquisition of landholdings as per land records	Yes <input type="checkbox"/> No <input type="checkbox"/> NA <input type="checkbox"/>	NA	
10.2	Consultation with affected persons	Yes <input type="checkbox"/> No <input type="checkbox"/> NA <input type="checkbox"/>	NA	
10.3	Name/ Details of consultation with NGOs	Yes <input type="checkbox"/> No <input type="checkbox"/> NA <input type="checkbox"/>		
10.4	Name/ Details of consultation with concerned government agencies	Yes <input type="checkbox"/> No <input type="checkbox"/> NA <input type="checkbox"/>		
10.5	Total land required, land area already available , land to be acquired identified	Yes <input type="checkbox"/> No <input type="checkbox"/> NA <input type="checkbox"/>		
10.6	Review of land acquisition using digital cadastral map by client	Yes <input type="checkbox"/> No <input type="checkbox"/> NA <input type="checkbox"/>	NA	
11	<b>Strip plan- additional details added</b>	Yes <input type="checkbox"/> No <input type="checkbox"/> NA <input type="checkbox"/>	NA	11
11.1	Details of centreline, existing structures, road furniture and other features	Yes <input type="checkbox"/> No <input type="checkbox"/> NA <input type="checkbox"/>	NA	11.1
11.2	Widening scheme	Yes <input type="checkbox"/> No <input type="checkbox"/> NA <input type="checkbox"/>	NA	11.2
11.3	New construction/ reconstruction of structures and amenities	Yes <input type="checkbox"/> No <input type="checkbox"/> NA <input type="checkbox"/>	NA	11.3
11.4	Existing and proposed right of way	Yes <input type="checkbox"/> No <input type="checkbox"/> NA <input type="checkbox"/>	NA	11.4
11.5	Clearances impacting each chainage	Yes <input type="checkbox"/> No <input type="checkbox"/> NA <input type="checkbox"/>	NA	11.5
12	<b>Conclusions and recommendations</b>	Yes <input type="checkbox"/> No <input type="checkbox"/> NA <input type="checkbox"/>	NA	
12.1	Conclusions and recommendations	Yes <input type="checkbox"/> No <input type="checkbox"/> NA <input type="checkbox"/>	NA	
12.2	Report fulfils project objectives and scope as per RFP	Yes <input type="checkbox"/> No <input type="checkbox"/> NA <input type="checkbox"/>	NA	
12.3	Report reviewed for errors and omissions	Yes <input type="checkbox"/> No <input type="checkbox"/> NA <input type="checkbox"/>	NA	
12.4	Compliance report prepared on client observations	Yes <input type="checkbox"/> No <input type="checkbox"/> NA <input type="checkbox"/>	NA	

## DPR Checklist - Stage 4 - Detailed Project Report (Structures)

General Details	
Project Name	
Consultant's Name	
Date of Review	

S.No	SECTION OF THE REPORT	YES/NO/NA	Details/ Specifications	Remarks
1	<b>Project background</b>	Yes <input type="checkbox"/> No <input type="checkbox"/> NA <input type="checkbox"/>	NA	
1.1	Project description <ul style="list-style-type: none"> <li>• Existing LC number</li> <li>• Start and End Chainage</li> <li>• Village/District</li> </ul>	Yes <input type="checkbox"/> No <input type="checkbox"/> NA <input type="checkbox"/>		
1.2	Project location map <ul style="list-style-type: none"> <li>• On State Map</li> <li>• On District Map</li> <li>• Latitude &amp; Longitude Coordinates of the LC</li> </ul>	Yes <input type="checkbox"/> No <input type="checkbox"/> NA <input type="checkbox"/>		
1.3	Details of Existing Level Crossing <ul style="list-style-type: none"> <li>• Number of Railway Tracks</li> <li>• Type of Railway Tracks (Broad/Metre/Narrow)</li> <li>• No. of trains per day</li> </ul>	Yes <input type="checkbox"/> No <input type="checkbox"/> NA <input type="checkbox"/>		
1.4	Justification for need of an ROB/RUB (on basis of TVU count)	Yes <input type="checkbox"/> No <input type="checkbox"/> NA <input type="checkbox"/>	NA	
1.5	Overview of land use plans	Yes <input type="checkbox"/> No <input type="checkbox"/> NA <input type="checkbox"/>	NA	
1.6	Overview of existing pavement conditions <ul style="list-style-type: none"> <li>• Number of Lanes</li> <li>• Type of Pavement (Flexible/Rigid/Surfaced/Unsurfaced)</li> </ul>	Yes <input type="checkbox"/> No <input type="checkbox"/> NA <input type="checkbox"/>		
1.7	Existing right of way details	Yes <input type="checkbox"/> No <input type="checkbox"/> NA <input type="checkbox"/>		
1.8	Any other details relevant to the project	Yes <input type="checkbox"/> No <input type="checkbox"/> NA <input type="checkbox"/>	NA	
2	<b>Social analysis of the project</b>	Yes <input type="checkbox"/> No <input type="checkbox"/> NA <input type="checkbox"/>	NA	
2.1	Project impact on stakeholders such as local people	Yes <input type="checkbox"/> No <input type="checkbox"/> NA <input type="checkbox"/>	NA	
2.2	Project impact on residential, commercial and public properties	Yes <input type="checkbox"/> No <input type="checkbox"/> NA <input type="checkbox"/>	NA	
2.3	Any other details relevant to the project	Yes <input type="checkbox"/> No <input type="checkbox"/> NA <input type="checkbox"/>	NA	
3	<b>Reconnaissance survey</b>	Yes <input type="checkbox"/> No <input type="checkbox"/> NA <input type="checkbox"/>	NA	
3.1	Geometric Features of the Existing Road <ul style="list-style-type: none"> <li>• Design Speed</li> <li>• Sight distance details</li> <li>• Horizontal Alignment Details</li> <li>• Vertical Alignment Details</li> <li>• Height of Embankment</li> </ul>	Yes <input type="checkbox"/> No <input type="checkbox"/> NA <input type="checkbox"/>		

S.No	SECTION OF THE REPORT	YES/NO/NA	Details/ Specifications	Remarks
3.2	Topographical Survey using LiDAR or equivalent technology as per IRC:SP:19 <ul style="list-style-type: none"> <li>• Gradient</li> <li>• Terrain</li> </ul>	Yes <input type="checkbox"/> No <input type="checkbox"/> NA <input type="checkbox"/>	NA	
3.3	Pavement composition and condition survey as per IRC:SP:19	Yes <input type="checkbox"/> No <input type="checkbox"/> NA <input type="checkbox"/>	NA	
3.4	Geological Survey <ul style="list-style-type: none"> <li>• Geological Map of the Area</li> <li>• Seismicity</li> </ul>	Yes <input type="checkbox"/> No <input type="checkbox"/> NA <input type="checkbox"/>	NA	
3.5	Climatic Conditions <ul style="list-style-type: none"> <li>• Temperature</li> <li>• Rainfall</li> <li>• Wind</li> </ul>	Yes <input type="checkbox"/> No <input type="checkbox"/> NA <input type="checkbox"/>	NA	
3.6	Land Use along the existing alignment <ul style="list-style-type: none"> <li>• Map of the Project Area depicting Agricultural/Habitation/Forest Area</li> </ul>	Yes <input type="checkbox"/> No <input type="checkbox"/> NA <input type="checkbox"/>	NA	
3.7	Details of Existing Structures <ul style="list-style-type: none"> <li>• Map of the Project Area depicting Hutments/Buildings/Temples/Public Building/Any Other Significant Structure</li> </ul>	Yes <input type="checkbox"/> No <input type="checkbox"/> NA <input type="checkbox"/>	NA	
3.8	Inventory and condition survey of culverts	Yes <input type="checkbox"/> No <input type="checkbox"/> NA <input type="checkbox"/>	NA	
3.9	Geo-technical and sub-soil explorations as per IRC:78	Yes <input type="checkbox"/> No <input type="checkbox"/> NA <input type="checkbox"/>	NA	
3.10	Number of Bore holes dug (holds for every pier and abutment)	Yes <input type="checkbox"/> No <input type="checkbox"/> NA <input type="checkbox"/>		
3.11	Field testing, soil sampling, laboratory testing as per IRC: 78	Yes <input type="checkbox"/> No <input type="checkbox"/> NA <input type="checkbox"/>	NA	
3.12	Recommendation of Foundation Type and Depth	Yes <input type="checkbox"/> No <input type="checkbox"/> NA <input type="checkbox"/>		
3.13	Hydraulic and Hydrological investigations as per IRC:5	Yes <input type="checkbox"/> No <input type="checkbox"/> NA <input type="checkbox"/>	NA	
3.14	High Flood Level specified	Yes <input type="checkbox"/> No <input type="checkbox"/> NA <input type="checkbox"/>	NA	
3.15	Depth of Water Table specified	Yes <input type="checkbox"/> No <input type="checkbox"/> NA <input type="checkbox"/>	NA	
3.16	Ponded Water Level specified	Yes <input type="checkbox"/> No <input type="checkbox"/> NA <input type="checkbox"/>	NA	
3.17	Materials Survey conducted as per IRC:SP:19	Yes <input type="checkbox"/> No <input type="checkbox"/> NA <input type="checkbox"/>	NA	
3.18	Sources of Naturally Occurring Aggregates specified <ul style="list-style-type: none"> <li>• Details of Borrow Pits with Distance from Project Site</li> <li>• Cost of Material/Transportation</li> </ul>	Yes <input type="checkbox"/> No <input type="checkbox"/> NA <input type="checkbox"/>		
3.19	Sources of Manufactured Items specified <ul style="list-style-type: none"> <li>• Details of Suppliers with Distance from Project Site</li> <li>• Cost of Material/Transportation</li> </ul>	Yes <input type="checkbox"/> No <input type="checkbox"/> NA <input type="checkbox"/>	NA	

S.No	SECTION OF THE REPORT	YES/NO/NA	Details/ Specifications	Remarks
3.19.1	Sources of environmentally friendly construction materials identified as per MoRT&H circular	Yes <input type="checkbox"/> No <input type="checkbox"/> NA <input type="checkbox"/>	NA	
3.20	Source of Water for construction specified as per IS:456	Yes <input type="checkbox"/> No <input type="checkbox"/> NA <input type="checkbox"/>	NA	
3.21	Any other details relevant to the project	Yes <input type="checkbox"/> No <input type="checkbox"/> NA <input type="checkbox"/>	NA	
4	<b>Traffic surveys and analysis</b>	Yes <input type="checkbox"/> No <input type="checkbox"/> NA <input type="checkbox"/>	NA	
4.1	Classified traffic volume counts using IHMCL data (7 day)	Yes <input type="checkbox"/> No <input type="checkbox"/> NA <input type="checkbox"/>	NA	
4.2	Traffic projection as per IRC:108	Yes <input type="checkbox"/> No <input type="checkbox"/> NA <input type="checkbox"/>	NA	
4.3	Projected Traffic data for 20 years	Yes <input type="checkbox"/> No <input type="checkbox"/> NA <input type="checkbox"/>	NA	
4.4	Current and Projected PCU	Yes <input type="checkbox"/> No <input type="checkbox"/> NA <input type="checkbox"/>		
4.5	Current and Projected TVU	Yes <input type="checkbox"/> No <input type="checkbox"/> NA <input type="checkbox"/>		
4.6	Axle load survey as per IRC:SP:19	Yes <input type="checkbox"/> No <input type="checkbox"/> NA <input type="checkbox"/>	NA	
4.7	Any other details relevant to the project	Yes <input type="checkbox"/> No <input type="checkbox"/> NA <input type="checkbox"/>	NA	
5	<b>Determination of whether ROB or RUB is appropriate</b>	Yes <input type="checkbox"/> No <input type="checkbox"/> NA <input type="checkbox"/>	NA	
5.1	Justification of whether ROB or RUB should be built	Yes <input type="checkbox"/> No <input type="checkbox"/> NA <input type="checkbox"/>	NA	
6	<b>Alignment Options Study</b>	Yes <input type="checkbox"/> No <input type="checkbox"/> NA <input type="checkbox"/>	NA	
6.1	At least two alignments proposed • Details of Alignments on Map	Yes <input type="checkbox"/> No <input type="checkbox"/> NA <input type="checkbox"/>	NA	
6.2	Length of the project along proposed alignment options	Yes <input type="checkbox"/> No <input type="checkbox"/> NA <input type="checkbox"/>	NA	
6.3	Land Acquisition required along alignment options	Yes <input type="checkbox"/> No <input type="checkbox"/> NA <input type="checkbox"/>	NA	
6.4	Cost Estimates of alternatives	Yes <input type="checkbox"/> No <input type="checkbox"/> NA <input type="checkbox"/>	NA	
6.5	Recommended Alignment with Justification	Yes <input type="checkbox"/> No <input type="checkbox"/> NA <input type="checkbox"/>		
6.6	Skew Angle of Proposed Alignment Specified	Yes <input type="checkbox"/> No <input type="checkbox"/> NA <input type="checkbox"/>		
6.7	Traffic Diversion Route Specified	Yes <input type="checkbox"/> No <input type="checkbox"/> NA <input type="checkbox"/>	NA	
6.8	Any other details relevant to the project	Yes <input type="checkbox"/> No <input type="checkbox"/> NA <input type="checkbox"/>	NA	
7	<b>Design Specifications</b>	Yes <input type="checkbox"/> No <input type="checkbox"/> NA <input type="checkbox"/>	NA	
7.1	Number of Lanes	Yes <input type="checkbox"/> No <input type="checkbox"/> NA <input type="checkbox"/>		
7.2	Width of ROB • Width of Carriageway • Width of Safety Kerbs • Width of Footpath • Any other	Yes <input type="checkbox"/> No <input type="checkbox"/> NA <input type="checkbox"/>		
7.3	Proposed Number of Lanes on ROB in line with PCU as per latest MoRTH guidelines	Yes <input type="checkbox"/> No <input type="checkbox"/> NA <input type="checkbox"/>	NA	

S.No	SECTION OF THE REPORT	YES/NO/NA	Details/ Specifications	Remarks
7.4	Proposed Length of the Project <ul style="list-style-type: none"> <li>Length of ROB</li> <li>Length of Viaduct</li> <li>Length of RE Wall</li> <li>Length of Approach Road</li> <li>Length of Service Road</li> </ul>	Yes <input type="checkbox"/> No <input type="checkbox"/> NA <input type="checkbox"/>		
7.5	Span Arrangement <ul style="list-style-type: none"> <li>Span Length</li> <li>Number of Spans</li> </ul>	Yes <input type="checkbox"/> No <input type="checkbox"/> NA <input type="checkbox"/>		
7.6	Are all spans of standardised length as per Railways standards ( <a href="https://ircep.gov.in/RCApproval/">https://ircep.gov.in/RCApproval/</a> ) <ul style="list-style-type: none"> <li>If non-standardised, suitable justification provided</li> </ul>	Yes <input type="checkbox"/> No <input type="checkbox"/> NA <input type="checkbox"/>	NA	
7.7	Details of Proposed Superstructure Design <ul style="list-style-type: none"> <li>Type</li> <li>Details of Material Use Proposed</li> <li>Drawings of Cross-Sections</li> </ul>	Yes <input type="checkbox"/> No <input type="checkbox"/> NA <input type="checkbox"/>	NA	
7.8	Details of Proposed Substructure Design <ul style="list-style-type: none"> <li>Type</li> <li>Details of Material Use Proposed</li> <li>Drawings of Cross-Sections</li> </ul>	Yes <input type="checkbox"/> No <input type="checkbox"/> NA <input type="checkbox"/>	NA	
7.9	Details of Proposed Pavement Design <ul style="list-style-type: none"> <li>Type</li> <li>Details of Material Use Proposed</li> <li>Thickness</li> <li>Design MSA</li> <li>Drawings of Cross-Sections</li> </ul>	Yes <input type="checkbox"/> No <input type="checkbox"/> NA <input type="checkbox"/>	NA	
7.10	Details of Drainage Structures Proposed	Yes <input type="checkbox"/> No <input type="checkbox"/> NA <input type="checkbox"/>	NA	
7.11	Any other details relevant to the project	Yes <input type="checkbox"/> No <input type="checkbox"/> NA <input type="checkbox"/>	NA	
8	<b>Cost estimates</b>	Yes <input type="checkbox"/> No <input type="checkbox"/> NA <input type="checkbox"/>	NA	
8.1	Summary of Cost Estimates (Refer following subsection)	Yes <input type="checkbox"/> No <input type="checkbox"/> NA <input type="checkbox"/>		
8.2	Detailed Abstract of Cost	Yes <input type="checkbox"/> No <input type="checkbox"/> NA <input type="checkbox"/>	NA	
8.3	Detailed Bills of Quantity	Yes <input type="checkbox"/> No <input type="checkbox"/> NA <input type="checkbox"/>	NA	
8.4	Detailed Rate Analysis	Yes <input type="checkbox"/> No <input type="checkbox"/> NA <input type="checkbox"/>	NA	
9	<b>Financial Viability</b>	Yes <input type="checkbox"/> No <input type="checkbox"/> NA <input type="checkbox"/>	NA	
9.1	Estimated cost details	Yes <input type="checkbox"/> No <input type="checkbox"/> NA <input type="checkbox"/>	NA	
9.2	Projected revenues details	Yes <input type="checkbox"/> No <input type="checkbox"/> NA <input type="checkbox"/>	NA	
9.3	Assumptions stated	Yes <input type="checkbox"/> No <input type="checkbox"/> NA <input type="checkbox"/>	NA	
9.4	Analysis and results <ul style="list-style-type: none"> <li>IRR</li> <li>Sensitivity Analysis</li> <li>Financial Viability</li> </ul>	Yes <input type="checkbox"/> No <input type="checkbox"/> NA <input type="checkbox"/>		
10	<b>Land Acquisition Study</b>	Yes <input type="checkbox"/> No <input type="checkbox"/> NA <input type="checkbox"/>	NA	

S.No	SECTION OF THE REPORT	YES/NO/NA	Details/ Specifications	Remarks
10.1	Land Acquisition Details <ul style="list-style-type: none"> <li>Total Land Required</li> <li>Land Area already available</li> <li>Area of Land to be Acquired</li> </ul>	Yes <input type="checkbox"/> No <input type="checkbox"/> NA <input type="checkbox"/>		
10.3	Details of LA Cost	Yes <input type="checkbox"/> No <input type="checkbox"/> NA <input type="checkbox"/>		
11	<b>Utility Shifting Study</b>	Yes <input type="checkbox"/> No <input type="checkbox"/> NA <input type="checkbox"/>	NA	
11.1	Results of GPR investigation	Yes <input type="checkbox"/> No <input type="checkbox"/> NA <input type="checkbox"/>	NA	
11.2	Utility relocation plan with existing / proposed location showing existing RoW and topographic details	Yes <input type="checkbox"/> No <input type="checkbox"/> NA <input type="checkbox"/>	NA	
11.3	Cost for relocation as per authority	Yes <input type="checkbox"/> No <input type="checkbox"/> NA <input type="checkbox"/>		
12	<b>General Arrangement Drawing</b>	Yes <input type="checkbox"/> No <input type="checkbox"/> NA <input type="checkbox"/>	NA	
12.1	Elevation of Railway Portion	Yes <input type="checkbox"/> No <input type="checkbox"/> NA <input type="checkbox"/>	NA	
12.2	Plan of Railway Portion	Yes <input type="checkbox"/> No <input type="checkbox"/> NA <input type="checkbox"/>	NA	
12.3	General Elevation	Yes <input type="checkbox"/> No <input type="checkbox"/> NA <input type="checkbox"/>	NA	
12.4	General Plan (showing complete ROB/RUB along with diversion)	Yes <input type="checkbox"/> No <input type="checkbox"/> NA <input type="checkbox"/>	NA	
12.5	Key Plan	Yes <input type="checkbox"/> No <input type="checkbox"/> NA <input type="checkbox"/>	NA	
12.6	Cross-Section of Railway Portion	Yes <input type="checkbox"/> No <input type="checkbox"/> NA <input type="checkbox"/>	NA	
12.7	3D engineered models of: <ul style="list-style-type: none"> <li>Existing structure, if any</li> <li>Proposed structure</li> <li>Utilities and other features in RoW</li> </ul>	Yes <input type="checkbox"/> No <input type="checkbox"/> NA <input type="checkbox"/>		

### Cost Summary Table

S.No.	Particulars	Cost Estimate(in '000)
1	<i>Cost of ROB Portion</i>	
	Foundation	
	Substructure	
	Superstructure	
	<b>Total-ROB Portion</b>	
2	<i>Cost of Viaduct</i>	
	Foundation	
	Substructure	
	Superstructure	
	<b>Total-Viaduct</b>	
3	<i>Cost of Approach Road</i>	
4	<i>Cost of RE Wall</i>	

S.No.	Particulars	Cost Estimate(in '000)
5	<i>Cost of Service Road</i>	
6	<i>Miscellaneous Costs</i>	
	Cost of Subway	
	Cost of Toll Plaza	
	Cost of Culverts	
	Any Other Costs	
	<b>Civil Cost of the Project</b>	
7	<i>Contingencies @x%</i>	
	<b>Total Civil Cost</b>	
8	<i>Supervision Charges @x%</i>	
9	<i>Cost of Quality Control @x%</i>	
10	<i>Maintenance Charges @x%</i>	
11	<i>Escalation Costs @x%</i>	
12	<i>Land Acquisition Costs</i>	
13	<i>Utility Shifting Costs</i>	
14	<i>Any Other Costs</i>	
	<b>Total Cost of the Project</b>	



## DPR Checklist - Stage 5 - Technical Schedules (Structures)

General Details	
Project Name	
Consultant's Name	
Date of Review	

S.No	SECTION OF THE REPORT	YES/NO/NA	Details/ Specifications	Remarks
1	Bid documents- EPC	Yes <input type="checkbox"/> No <input type="checkbox"/> NA <input type="checkbox"/>	NA	
2	<b>Bid documents- Other, if any</b>	Yes <input type="checkbox"/> No <input type="checkbox"/> NA <input type="checkbox"/>	NA	
3	<b>Draft concession agreement</b>	Yes <input type="checkbox"/> No <input type="checkbox"/> NA <input type="checkbox"/>	NA	
3	<b>Schedule C - Project facilities</b>	Yes <input type="checkbox"/> No <input type="checkbox"/> NA <input type="checkbox"/>	NA	
4	<b>Schedule D - Specifications and standards</b>	Yes <input type="checkbox"/> No <input type="checkbox"/> NA <input type="checkbox"/>	NA	
5	<b>Any other relevant details</b>	Yes <input type="checkbox"/> No <input type="checkbox"/> NA <input type="checkbox"/>	NA	

## DPR Checklist - Stage 6 - LA and Clearances II Report (Structures)

General Details	
Project Name	
Consultant's Name	
Date of Review	

S.No	SECTION OF THE REPORT	YES/NO/NA	Details/ Specifications	Remarks
1	<b>Executive Summary</b>	Yes <input type="checkbox"/> No <input type="checkbox"/> NA <input type="checkbox"/>	NA	
2	<b>Environment Clearance</b>	Yes <input type="checkbox"/> No <input type="checkbox"/> NA <input type="checkbox"/>	NA	
2.1	Details of public hearings completed	Yes <input type="checkbox"/> No <input type="checkbox"/> NA <input type="checkbox"/>		
2.2	Date of final environment clearance by competent authority	Yes <input type="checkbox"/> No <input type="checkbox"/> NA <input type="checkbox"/>		
3	<b>Forest Clearance</b>	Yes <input type="checkbox"/> No <input type="checkbox"/> NA <input type="checkbox"/>	NA	
3.1	Date/ Details of Joint site inspection with DFO/ competent authority	Yes <input type="checkbox"/> No <input type="checkbox"/> NA <input type="checkbox"/>		
3.2	Date of Stage I forest clearance approval by competent authority	Yes <input type="checkbox"/> No <input type="checkbox"/> NA <input type="checkbox"/>		
3.3	Date of final forest clearance approval by competent authority	Yes <input type="checkbox"/> No <input type="checkbox"/> NA <input type="checkbox"/>		
4	<b>Wildlife Clearance</b>	Yes <input type="checkbox"/> No <input type="checkbox"/> NA <input type="checkbox"/>	NA	
4.1	Date/ Details of joint site inspection with DFO/ competent authority	Yes <input type="checkbox"/> No <input type="checkbox"/> NA <input type="checkbox"/>		
4.2	Date of final wildlife clearance approval by competent authority	Yes <input type="checkbox"/> No <input type="checkbox"/> NA <input type="checkbox"/>		
5	<b>Utility Clearances (Electricity)</b>	Yes <input type="checkbox"/> No <input type="checkbox"/> NA <input type="checkbox"/>	NA	
5.1	Date/ Details of Joint site inspection with competent authority	Yes <input type="checkbox"/> No <input type="checkbox"/> NA <input type="checkbox"/>		
5.2	Date of estimate submission by competent authority	Yes <input type="checkbox"/> No <input type="checkbox"/> NA <input type="checkbox"/>		
5.3	Date of estimate approval by competent authority	Yes <input type="checkbox"/> No <input type="checkbox"/> NA <input type="checkbox"/>		
5.4	Approved utility shifting proposal	Yes <input type="checkbox"/> No <input type="checkbox"/> NA <input type="checkbox"/>		
5.5	Details of approved contractors, SoR and deposit details for user agency	Yes <input type="checkbox"/> No <input type="checkbox"/> NA <input type="checkbox"/>	NA	
5.6	Utilities checklist, no upgradation certificate attached	Yes <input type="checkbox"/> No <input type="checkbox"/> NA <input type="checkbox"/>		
6.2	Date of estimate submission by competent authority	Yes <input type="checkbox"/> No <input type="checkbox"/> NA <input type="checkbox"/>		
6.3	Date of estimate approval by competent authority	Yes <input type="checkbox"/> No <input type="checkbox"/> NA <input type="checkbox"/>		
6.4	Approved utility shifting proposal	Yes <input type="checkbox"/> No <input type="checkbox"/> NA <input type="checkbox"/>		
6.5	Details of approved contractors, SoR and deposit details for user agency	Yes <input type="checkbox"/> No <input type="checkbox"/> NA <input type="checkbox"/>	NA	
6.6	Utilities checklist, no upgradation certificate attached	Yes <input type="checkbox"/> No <input type="checkbox"/> NA <input type="checkbox"/>		

S.No	SECTION OF THE REPORT	YES/NO/NA	Details/ Specifications	Remarks
7.2	Date of estimate submission by competent authority	Yes <input type="checkbox"/> No <input type="checkbox"/> NA <input type="checkbox"/>		
7.3	Date of estimate approval by competent authority	Yes <input type="checkbox"/> No <input type="checkbox"/> NA <input type="checkbox"/>		
7.4	Approved utility shifting proposal	Yes <input type="checkbox"/> No <input type="checkbox"/> NA <input type="checkbox"/>		
7.5	Details of approved contractors, SoR and deposit details for user agency	Yes <input type="checkbox"/> No <input type="checkbox"/> NA <input type="checkbox"/>	NA	
7.6	Utilities checklist, no upgradation certificate attached	Yes <input type="checkbox"/> No <input type="checkbox"/> NA <input type="checkbox"/>		
8.2	Date of final approval of GAD by competent authority	Yes <input type="checkbox"/> No <input type="checkbox"/> NA <input type="checkbox"/>		
9	<b>Other Clearances</b>	Yes <input type="checkbox"/> No <input type="checkbox"/> NA <input type="checkbox"/>	NA	
9.1	Date of final approval by competent authority	Yes <input type="checkbox"/> No <input type="checkbox"/> NA <input type="checkbox"/>		
10	<b>Land Acquisition</b>	Yes <input type="checkbox"/> No <input type="checkbox"/> NA <input type="checkbox"/>	NA	
10.1	Draft 3a notification submitted	Yes <input type="checkbox"/> No <input type="checkbox"/> NA <input type="checkbox"/>	NA	
10.2	Review of 3a notification by client	Yes <input type="checkbox"/> No <input type="checkbox"/> NA <input type="checkbox"/>	NA	
10.3	Date of 3a gazette notification	Yes <input type="checkbox"/> No <input type="checkbox"/> NA <input type="checkbox"/>		
10.4	Draft 3a notification submitted	Yes <input type="checkbox"/> No <input type="checkbox"/> NA <input type="checkbox"/>	NA	
10.5	Review of 3A notification by client	Yes <input type="checkbox"/> No <input type="checkbox"/> NA <input type="checkbox"/>	NA	
10.6	Date of 3A gazette notification	Yes <input type="checkbox"/> No <input type="checkbox"/> NA <input type="checkbox"/>		
10.7	Date of Joint Measurement Survey with competent authority	Yes <input type="checkbox"/> No <input type="checkbox"/> NA <input type="checkbox"/>		
10.7.1	Date of survey	Yes <input type="checkbox"/> No <input type="checkbox"/> NA <input type="checkbox"/>	NA	
10.7.2	Land type –by survey number	Yes <input type="checkbox"/> No <input type="checkbox"/> NA <input type="checkbox"/>	NA	
10.7.3	Nature of Land –by survey number	Yes <input type="checkbox"/> No <input type="checkbox"/> NA <input type="checkbox"/>	NA	
10.7.4	Ownership status of plots- by survey number	Yes <input type="checkbox"/> No <input type="checkbox"/> NA <input type="checkbox"/>	NA	
10.7.5	Verification of area to be acquired – by survey number	Yes <input type="checkbox"/> No <input type="checkbox"/> NA <input type="checkbox"/>	NA	
10.7.6	List of structures on each plot	Yes <input type="checkbox"/> No <input type="checkbox"/> NA <input type="checkbox"/>	NA	
10.7.7	Sketches of updated alignment	Yes <input type="checkbox"/> No <input type="checkbox"/> NA <input type="checkbox"/>	NA	
10.7.8	Verification from Land revenue department	Yes <input type="checkbox"/> No <input type="checkbox"/> NA <input type="checkbox"/>	NA	
10.7.9	Verification by CALA office	Yes <input type="checkbox"/> No <input type="checkbox"/> NA <input type="checkbox"/>	NA	

### 1.1.3 DPR Checklist - Stage 7 - Award determination (Structures)

General Details	
Project Name	
Consultant's Name	
Date of Review	

S.No	SECTION OF THE REPORT	YES/NO/NA	Details/ Specifications	Remarks
1	<b>Executive Summary</b>	Yes <input type="checkbox"/> No <input type="checkbox"/> NA <input type="checkbox"/>	NA	
2	<b>Village level summary</b>	Yes <input type="checkbox"/> No <input type="checkbox"/> NA <input type="checkbox"/>	NA	
2.1	Total private and public land being acquired	Yes <input type="checkbox"/> No <input type="checkbox"/> NA <input type="checkbox"/>	NA	
2.2	Variation in area and nature of land against 3D with justification	Yes <input type="checkbox"/> No <input type="checkbox"/> NA <input type="checkbox"/>	NA	
2.3	Method used by CALA to arrive at award	Yes <input type="checkbox"/> No <input type="checkbox"/> NA <input type="checkbox"/>	NA	
2.4	Date of award by CALA and approval by NHAI along with valuation report			
2.5	Total award calculated and details of deviation from RFCTLARR act	Yes <input type="checkbox"/> No <input type="checkbox"/> NA <input type="checkbox"/>	NA	
3	<b>In detail</b>	Yes <input type="checkbox"/> No <input type="checkbox"/> NA <input type="checkbox"/>	NA	
3.1	Updated land acquisition tracker with parcel-wise status of: <ul style="list-style-type: none"> <li>• Notifications</li> <li>• Award</li> <li>• Disbursement</li> </ul>	Yes <input type="checkbox"/> No <input type="checkbox"/> NA <input type="checkbox"/>	NA	
3.2	Valuation report and details of award calculation- verification by state authority to be included	Yes <input type="checkbox"/> No <input type="checkbox"/> NA <input type="checkbox"/>	NA	
3.3	Claims report	Yes <input type="checkbox"/> No <input type="checkbox"/> NA <input type="checkbox"/>	NA	
3.4	Copies of notifications published	Yes <input type="checkbox"/> No <input type="checkbox"/> NA <input type="checkbox"/>	NA	
3.5	Copies of land possession certificates received	Yes <input type="checkbox"/> No <input type="checkbox"/> NA <input type="checkbox"/>	NA	
4	<b>Conclusions and recommendations</b>	Yes <input type="checkbox"/> No <input type="checkbox"/> NA <input type="checkbox"/>	NA	
4.1	Conclusions and recommendations	Yes <input type="checkbox"/> No <input type="checkbox"/> NA <input type="checkbox"/>	NA	
4.2	Report fulfils project objectives and scope as per RFP	Yes <input type="checkbox"/> No <input type="checkbox"/> NA <input type="checkbox"/>	NA	
4.3	Report reviewed for errors and omissions	Yes <input type="checkbox"/> No <input type="checkbox"/> NA <input type="checkbox"/>	NA	
4.4	Compliance report prepared on client observations	Yes <input type="checkbox"/> No <input type="checkbox"/> NA <input type="checkbox"/>	NA	

## 1.1.4DPR Checklist - Stage 8 - Land possession report (Structures)

General Details	
Project Name	
Consultant's Name	
Date of Review	

S.No	SECTION OF THE REPORT	YES/NO/NA	Details/ Specifications	Remarks
1	<b>Executive Summary</b>	Yes <input type="checkbox"/> No <input type="checkbox"/> NA <input type="checkbox"/>	NA	
2	<b>Village level summary</b>	Yes <input type="checkbox"/> No <input type="checkbox"/> NA <input type="checkbox"/>	NA	
2.1	Total private and public land being acquired	Yes <input type="checkbox"/> No <input type="checkbox"/> NA <input type="checkbox"/>	NA	
2.2	Date of final award by CALA and approval by NHA			
2.3	Status of disbursement on date of receipt of Land possession certificate	Yes <input type="checkbox"/> No <input type="checkbox"/> NA <input type="checkbox"/>	NA	
2.4	Key issues being faced in completing land acquisition, if any	Yes <input type="checkbox"/> No <input type="checkbox"/> NA <input type="checkbox"/>	NA	
3	<b>In detail</b>	Yes <input type="checkbox"/> No <input type="checkbox"/> NA <input type="checkbox"/>	NA	
3.1	Updated land acquisition tracker with status of: <ul style="list-style-type: none"> <li>• Notifications</li> <li>• Award</li> <li>• Disbursement</li> </ul>	Yes <input type="checkbox"/> No <input type="checkbox"/> NA <input type="checkbox"/>	NA	
3.2	Final award and claims report	Yes <input type="checkbox"/> No <input type="checkbox"/> NA <input type="checkbox"/>	NA	
3.3	Copies of notifications published, land possession certificates received	Yes <input type="checkbox"/> No <input type="checkbox"/> NA <input type="checkbox"/>	NA	
4	<b>Conclusions and recommendations</b>	Yes <input type="checkbox"/> No <input type="checkbox"/> NA <input type="checkbox"/>	NA	
4.1	Conclusions and recommendations	Yes <input type="checkbox"/> No <input type="checkbox"/> NA <input type="checkbox"/>	NA	
4.2	Report fulfils project objectives and scope as per RFP	Yes <input type="checkbox"/> No <input type="checkbox"/> NA <input type="checkbox"/>	NA	
4.3	Report reviewed for errors and omissions	Yes <input type="checkbox"/> No <input type="checkbox"/> NA <input type="checkbox"/>	NA	
4.4	Compliance report prepared on client observations	Yes <input type="checkbox"/> No <input type="checkbox"/> NA <input type="checkbox"/>	NA	
5	<b>GIS Map containing digitised details of land parcels acquired with all relevant details</b>	Yes <input type="checkbox"/> No <input type="checkbox"/> NA <input type="checkbox"/>	NA	

### Appendix VIII- Sample Executive Summary of Detailed Project Report



National Highways Authority of India  
(Ministry of Road Transport & Highways)  
Government of India

Executive summary of detailed project report for:

*[Project name, stretch, state]*

*All figures, details and graphs in this template are illustrative. Consultants are to add actual details and expand tables, chapters as needed while keeping the format and information required in each chapter as suggested. Please delete this sticker upon completion*

**DPR Consultant**

[Name and logo of consulting agency]

## Table of Contents

<b><u>1</u></b>	<b><u>Introduction</u></b>	<b>281</b>
<b><u>2</u></b>	<b><u>Project overview</u></b>	<b>282</b>
2.1	<u>Key features of project</u>	282
2.2	<u>Key plan of existing project stretch</u>	284
<b><u>3</u></b>	<b><u>Traffic demands on project road</u></b>	<b>285</b>
3.1	<u>Traffic volume surveys</u>	285
3.2	<u>Axle load survey</u>	286
3.3	<u>Traffic volume forecast</u>	286
3.4	<u>Turning movement surveys</u>	287
<b><u>4</u></b>	<b><u>Pavement and corridor surveys</u></b>	<b>288</b>
4.1	<u>Pavement condition and distress seen</u>	288
4.2	<u>Pavement composition</u>	288
4.3	<u>Pavement strength</u>	289
4.4	<u>Sub-grade soil survey</u>	289
<b><u>5</u></b>	<b><u>Improvement proposals</u></b>	<b>290</b>
5.1	<u>Proposed alignment</u>	290
5.2	<u>Bypasses proposed</u>	290
5.3	<u>Road geometry</u>	291
5.4	<u>Widening scheme</u>	291
5.5	<u>Pavement design</u>	291
5.6	<u>Design of structures</u>	293
5.7	<u>Intersections and grade separators</u>	293
5.8	<u>Toll plazas</u>	294
5.9	<u>Wayside amenities proposed</u>	294
<b><u>6</u></b>	<b><u>Environmental impact assessment</u></b>	<b>295</b>
6.1	<u>Impact and clearances needed</u>	295
6.2	<u>Cost of environmental mitigation</u>	295
<b><u>7</u></b>	<b><u>Social impact assessment and Land acquisition</u></b>	<b>296</b>
7.1	<u>Social impact assessment</u>	296
7.2	<u>Land acquisition requirements</u>	296
7.3	<u>Key risks envisaged in land acquisition</u>	296
<b><u>8</u></b>	<b><u>Utilities shifting and clearances</u></b>	<b>297</b>
8.1	<u>Utilities shifting estimates</u>	297
8.2	<u>Total cost of utilities shifting</u>	297
<b><u>9</u></b>	<b><u>Project cost estimates</u></b>	<b>298</b>

<b><u>10</u></b>	<b><u>Material investigation</u></b>	<b>299</b>
10.1	<u>Borrow pits for soil</u>	299
10.2	<u>Sand</u>	299
10.3	<u>Gravel</u>	299
10.4	<u>Fly ash</u>	299
10.5	<u>Bitumen</u>	299
10.6	<u>Cement</u>	299
10.7	<u>Other local material available</u>	301
10.8	<u>Key risks</u>	301
10.9	<u>Location of material sources</u>	302
<b><u>11</u></b>	<b><u>Potential for value engineering and innovative technologies</u></b>	<b>303</b>
<b><u>12</u></b>	<b><u>Economic and financial analysis</u></b>	<b>304</b>
12.1	<u>Economic analysis of the project</u>	304
12.2	<u>Financial analysis</u>	304
<b><u>13</u></b>	<b><u>Execution plan</u></b>	<b>306</b>
13.1	<u>Packaging</u>	306
13.2	<u>Bidding mode and timelines</u>	306
13.3	<u>Construction time and planning</u>	306
<b><u>14</u></b>	<b><u>Conclusions and recommendation</u></b>	<b>307</b>



## 1. Introduction

The National Highways Authority of India proposes to implement the <re> the development, maintenance and management of the <NH-xx> stretch from <Origin> to <Destination> from chainage <aa km> to <bb km> into <proposed improvement, xx lane road/ expressway etc.> under the NHDP Phase V programme. The proposed project road has been selected to <primary reason for project- e.g. to improve connectivity and ease congestion between aa bb>

<Consultant> was appointed in <mm/yyyy> to prepare the detailed project report for the project road, and this executive summary covers is submitted along with the <draft/final> detailed project report to cover the key aspects of the project.

<Any special circumstances or requests made by the Authority for the project that affect the consultancy assignment e.g.: NHAI desired to restructure project into two packages, bifurcating the project road at Betulnagar, this report has been revised and resubmitted providing improvement proposals and bid documents separately for the two stretches>

## 2. Project overview

As described earlier the project road lies on NH xx (previously NH yy) and connects <origin> with <destination>, passing through the states of <state 1, state 2>. The proposed project alignment passes through <towns/junctions a, b, c, d> for a total length of <xx km>.



Figure 1: Location of project road

### 2.1. Key features of project

Table 1: Key features of project

Attributes	Details
NH No	Xx (old) Yy (new)
Origin- Destination	Origin-destination Origin point Lat/long – destination point lat/long
Via towns	Town 1, 2, 3, 4
Existing carriageway	2L (7.0m) over 80% of the road stretch with 4L (16.0m) in 20% of the stretch in some urban locations
Service lanes and slip roads	Service lanes of 2-4m width for 16 km, largely in urban areas
Shoulder	2L has paved shoulder of 1-2m width
Condition of existing pavement	Good to fair

Right of way	Typically 45 m along entire stretch
Land use along project road	Predominant land use in the area is agricultural (60% on LHS, 50% on RHS), with the rest being urban and forest area (20% on LHS, RHS)
Traffic on the stretch	Largely commercial, with trucks accounting for 80% of vehicle volume
Toll infrastructure	There are no toll plazas in the current stretch
Terrain	Primarily plain and rolling, passing through x settlements
Structures along stretch	69 structures- 3 ROBs, 7 major bridges, 2 flyovers, 9 minor bridges, 16 VUP/PUPs and 32 culverts
User amenities along stretch	32 bus shelters, 7 truck lay-byes, and 1 rest area
Key utilities in the proposed RoW	4 km 66 kV UG line with 3 crossings, 30in water main for 7.3 km
Forest Stretches along RoW	Xx km of road from <point a> to <point b> crosses <type of forest> <forest name>
Rail crossings along RoW	Railway LC no <x> at chainage yy on the <origin station> to <destination station> rail line at railway chainage zz
Other clearance related aspects	<please describe any other clearances that will be required for the project>

## 2.2. Key plan of existing project stretch

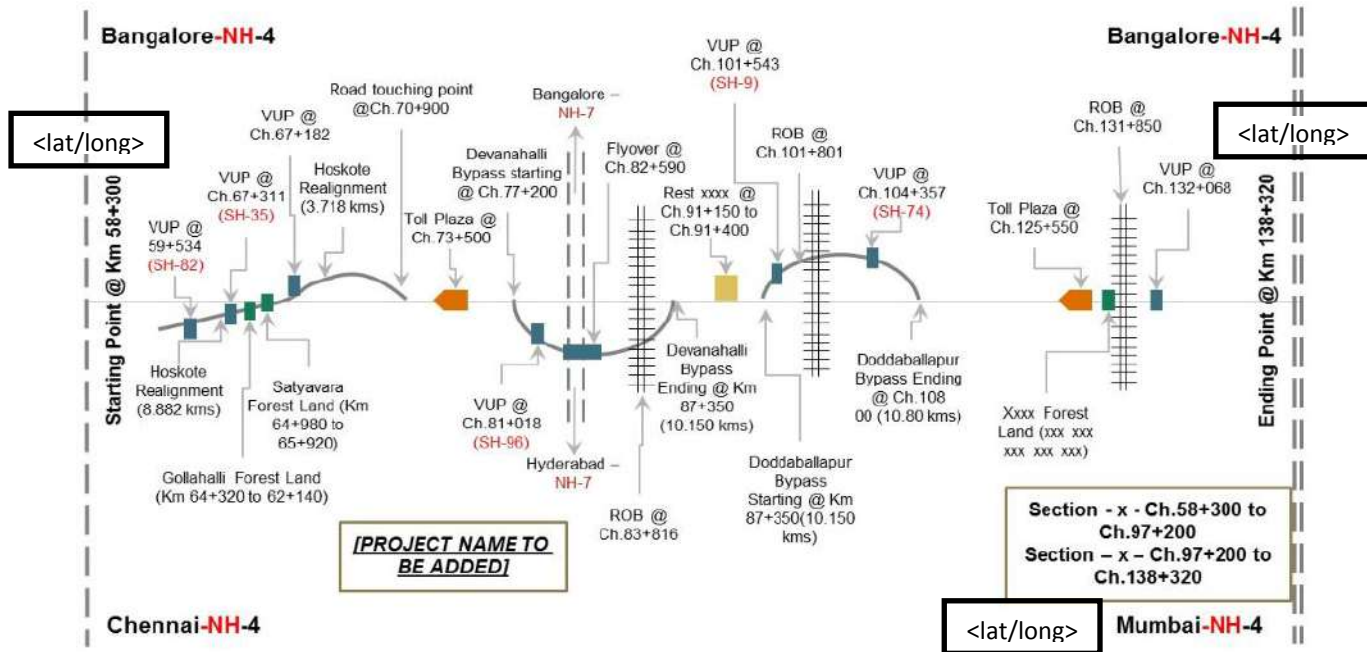

Figure 2: Key plan of existing project road

### 3. Traffic demands on project road

#### 3.1. Traffic volume surveys

For the purposes of traffic projections and lane design, <xx> individual sections of road were considered:

**Table 2: Traffic survey locations**

Section	Chainages	Length (Kms)		Volume Count Locations	Remarks
1	Km 163.0 - 192.0	29.0		Km 177.0, 45.0	Kasia/Tonta mines near 192.000
2	Km 192.0 - 219.0	27.0		Km 201.50	End point of proposed Koida bypass at km 218.250

Traffic volume surveys for the project road were < available from IHMCL for x locations> and were carried out at <x> additional locations along the project road in the month of <mm/yyyy>. The results are as follows:

**Table 3: Results of traffic surveys conducted**

Homogenous section	1	1	2	
Chainage	45.00	177.00	201.50	
Source of data	IHMCL	Consultant	Consultant	
Bicycle	47	75	61	
2 Wheeler	3320	3288	2630	
3 Wheeler	32	47	30	
Tractor	24	18	22	
Tractor with Trailer	389	385	341	
2 Axle SCV	436	386	388	
LMV 2 axle	3561	3545	3327	
LCV 2 Axle	577	603	563	
2 Axle Truck or Bus	908	987	1014	
3 Axle Truck or Bus	1142	1062	1086	
Multi Axle Vehicles MAV	2033	1962	1994	
Oversized Vehicle OSV	2	1	3	
Cycle	0	0	0	
Earth Moving Equipment	0	0	0	
AADT (in vehicles)	12471	12359	11459	

<b>AADT (in PCUs)</b>	34000	xx	xx	
-----------------------	-------	----	----	--

### 3.2. Axle load survey

Axle load surveys were conducted at <x> locations using <xxxx> to understand the actual load spectrum of commercial vehicles plying on the project road. The results of the load survey, were converted to Vehicle Damage Factor (VDF) using equivalency factors from <IRC xx> for the purpose of MSA calculations

**Table 4: Axle load survey results**

Mode	Section 1		Section 2		Section 2	
	Observed-at chainage xx	Recommended	Observed-at chainage xx	Recommended	Observed-at chainage xx	Recommended
<b>LCV</b>	0.47	0.47	0.45	0.45		
<b>2-axle</b>	3.97	3.97	3.57	3.97		
<b>3-axle</b>	3.63	3.63	3.26	3.26		
<b>MAV</b>	4.92	4.92	4.07	4.07		
<b>Bus</b>	0.78	0.82	0.82	0.82		

### 3.3. Traffic volume forecast

Traffic volume forecast was developed using the <xx> method and converted to Million Standard Axles (MSA) for the purposes of pavement design. The cumulative load in MSA for each section is given as under for various horizon years:

**Table 5: Projected traffic load on project road in MSA**

MSA	In x+15		In x+30	
	LHS	RHS	LHS	RHS
1	23.31	22		
2	33	40		

### 3.4. Turning movement surveys

Classified direction wise turning movement surveys were conducted at <x> intersections to determine the need for re-design and addition of structure at the intersection

SL. No.	Existing Chainage	Location	Total Volume PCU	Peak Hour Volume PCU	Peak Hour	Intersection type	Grade separator proposed
1	0.300	xxx	30988	1915	17:00 - 18:00	3 arm	No
2	6.200	xxx	28077	1962	09:00 - 10:00	4 arm	No
3	10.200	xxx	53333	3599	15:00 - 16:00	5 arm	Yes
4	28.000	xxx	64315	3884	10:00 - 11:00	4 arm	Yes

**Table 6: Turning movement survey results**

#### 4. Pavement and corridor surveys

##### 4.1. Pavement condition and distress seen

The overall pavement condition <description of overall pavement condition- e.g. from poor to very poor, with high roughness and significant presence of potholes and raveling>

**Table 7: Condition survey of existing pavement**

Type of distress	Length affected, in Kms				
	Area <=10 %	Area 10 %-25 %	Area 25 %-50 %	Area 50 %-75%	Area >75 %
Total Cracking	36	70	0	0	0
Potholes	28	23	55	0	0
Patching	44	61	1	0	0
Raveling	80	4	22	0	0
<other categories seen>					
Total	106	106	106	106	106

##### 4.2. Pavement composition

The existing pavement structure is a <rigid/flexible/inverted etc.> pavement consisting of sub-grade and <x> additional layers. The summary of pavement composition seen is as follows

**Table 8: Composition of existing pavement**

Section	Bituminous course (mm)		Granular course (mm)		Xx (mm)	
	Min	Max	Min	Max	Min	Max
1	50	350	100	600		
2	40	300	80	500		
X						



### 4.3. Pavement strength

<xxx FWD/BBD> was carried out to test the strength of the existing pavement, and the characteristic deflection values have been calculated for each homogeneous section of road to enable design of an overlay for the road.

**Table 9: Strength of existing pavement**

Section	Chainage		Distance	Characteristic deflection
	Start	End	Km	Mm
1	0.400	2.400	2.000	1.6
2	2.400	10.000	7.600	1.3
X				

### 4.4. Sub-grade soil survey

Extensive review of available soil information and testing was done to understand the sub-grade characteristics. Summary of soil investigation surveys is as follows:

**Table 10: Soil investigation survey results**

Attribute	Results	Comments
Sub-grade CBR range (%)	0.6%-14%	Low over large lengths of section
Degree of compaction (% of MDD)	~95%	Sufficient as per MoRTH guidelines
Swelling ratio (%)	2.5 to 32%	Significant variation seen across stretch
<other attributes>		

**Table 11: Soil types observed**

Soil type	% of length	Plasticity index	Comments
Clayey sand (SC)	34%	3 to 15	Poorly graded sand clay mixture
Silty sand (SM)	9%	Non-plastic	Poorly graded
Clayey gravel (GC)	9%	11 to 13	Mixture of gravel, sand and silt

## 5. Improvement proposals

### 5.1. Proposed alignment

The final alignment chosen for the project in consultation with <xx, yy> will <be along current project road/ pass through xx, yy new towns- short description of alignment with changes if any>.



Figure 3: Map showing proposed alignment of project road

### 5.2. Bypasses proposed

Given increasing urban traffic and congestion and the lack of available RoW in urban areas through the project route, <x> urban areas are proposed to be by-passed in the proposed project alignment

Table 12: Proposed by-passes along project length

Urban area to be bypassed	Bypass plan			Key driver for by-pass
	Start chainage	End chainage	Length proposed	
Nagar 1	45.000	52.000	21.000	Heavy local traffic of ~10,000 PCUs in town limits
Xxxx				

### 5.3. Road geometry

The project road has been re-designed to accommodate speeds of <xx>, adopted as per <standard or consultation with NHAI>. Enabling this higher speed will require re-design and re-alignment of the road in certain sections given their <description of poor geometry>.

### 5.4. Widening scheme

Basis traffic information available, level of service requirements and consultation with <NHAI, local authorities etc.>, the following lane configuration is adopted for the project road:

**Table 13: Lane configuration planned for project road**

Section	Chainage		Traffic forecast k PCUs in 20xx	Lane config.	Service lanes	Comments
	Start	End				
1	0.00	2.400	43.5	6	Yes	High urban traffic influx
2	2.400	60.400	16.4	4	No	
3						
xx						

Basis availability of RoW and land acquisition constraints, a widening scheme has been proposed that makes optimum use of existing ROW and minimizes need for land acquisition in urban areas, a summary of which is given below:

**Table 14: Summary of widening type proposed**

Sl no	Type of widening	Length, Km
1	Concentric	2.400
2	Eccentric, Right	34.600
3	Eccentric, Left	33.800
4	Green field	16.000

### 5.5. Pavement design

#### 5.5.1. Design period, loading and pavement type

Using the projected traffic, VDF values, lane and directional distribution factors, the design traffic loading used for the project is <xx to yy> MSA.

Through preliminary design and lifecycle comparisons, the <flexible/rigid/inverted> type of pavement was chosen for construction with a design life of <xx> years as per <IRC/MoRTH/NHAI standards/request> has been considered for design.

### 5.5.2. Design sub-grade strength

Considering the soil investigations conducted in the project road area, and the availability of suitable soil in the region, the following sub-grade strength has been assumed to vary from <xx%> to <yy%> for various sections of the highway

### 5.5.3. Pavement composition for new carriageway

The proposed pavement composition for the new sections carriageway basis <standards>, subgrade strength and design traffic is:

**Table 15: Proposed pavement composition**

Section	Design Chainage		Sub-grade strength	Pavement loading	Layer thickness (mm)				
	Start	End	Min % CBR	MSA	GSB	WMM	DBM	BC	xx
1	0.400	2.400	10%	40	200	250	95-125	40	
2	2.400	10.000	8%						
X									

### 5.5.4. Strengthening of existing pavement

The strengthening requirements for the existing pavement have been estimated from eh deflection measurements and estimated traffic loadings. The designed overlay proposed is as below:

**Table 16: Overlay thickness required**

Section	Chainage		Distance	Characteristic deflection	Overlay thickness (mm)	
	Start	End	Km	Mm	DBM	Xx
1	0.400	2.400	2.000	1.6	95	40
2	2.400	10.000	7.600	1.3	50	40
X						

### 5.5.5. Pavement design for service lanes

Pavement for service lanes is designed for MSA of xx-yy with a design CBR of ~xx%. The composition for the <flexible/rigid> service lane pavement along the project corridor is as follows:

**Table 17: Pavement composition for service road**

Layer	Layer Thickness in mm
SDBC	25
DBM	50
WMM	250
GSB	150

### 5.6. Design of structures

Along the project stretch, there are several bridges, culverts, under/overpasses and flyovers. A summary of the total number and proposed additions is given in the table below

**Table 18: Proposed improvement to structures along project road**

SI No	Structure	Existing	Dismantle	Widen	Reconstruct	Construct in parallel	New construction	Total
1	Major bridge	4	1	-	1	2	3	7
2	Minor bridge							
3	Flyover							
4	Vehicle overpass							
5	Vehicle underpass							
6	Passenger under pass							
7	Culverts							
8	xxx							

### 5.7. Intersections and grade separators

Based on the traffic and turning movement surveys conducted, <xx> junctions have been identified for redesign or grade separation, the details of which are given below

**Table 19: Proposed intersection improvement**

SL. No.	Existing Chainage	Location	Est total vol (k PCU)	Est Peak Hour Vol (k PCU)	Improvement proposed
1	10.200	xxx	53333	3599	Grade separator
2	28.000	xxx	64315	3884	Grade separator

SL. No.	Existing Chainage	Location	Est total vol (k PCU)	Est Peak Hour Vol (k PCU)	Improvement proposed
3					
4					

### 5.8. Toll plazas

Based on the traffic surveys, O-D surveys and layout of project road, <xx> toll plazas are proposed along the project road:

**Table 20: Location of current and proposed toll plazas**

SI No	Existing chainage	Design chainage	Location	Existing no of lanes	Proposed no of lanes
1	20.400	22.600	Near origin	2	6
2	95.000	101.500	Near via-nagar junction	New	6
x	xx	xx			

### 5.9. Wayside amenities proposed

<local discussions, discussions with authority, demand modelling etc.> was conducted to locate various way-side amenities across the project road. A summary of the improvements proposed is given below:

**Table 21: Proposed user amenities along project stretch**

SI no	Amenity type	Current	Proposed	Comments
1	Passenger rest stops	0	2	
2	Truck lay-byes	5	15	High demand due to urban areas along stretch
3	Bus bays	4	10	Limited increase due to scarcity of land
4	Bus shelters	2	34	Proposed in lieu of bus-bays
5	Petrol bunks	1	5	Severe shortage along stretch
6				

## 6. Environmental impact assessment

### 6.1. Impact and clearances needed

A environmental impact study was undertaken during the process of creating the detailed project report to understand impact of the project road on the surrounding ecology and environment. The project road is categorized as a category <xx> project by the MoEF and as it is <xx km> in length, it <will/will not> require environmental clearances.

The proposed project <involves/does not involve> the acquisition of forest/ecologically sensitive land, felling of trees and will impact wildlife habitat and will hence require individual clearances for each. A summary of the environmental impact and clearances required is provided below

**Table 22: Environmental impact and clearances required**

SI No	Impact type	Description	Clearance status
1	Environmental clearance	Required due to nature of project, category 'A'	Form 1 submitted dd/mm/yyyy and environmental clearance obtained on dd/mmm/yyyy
2	Diversion of forest land	27.72 ha of land in <xx> district will need to be acquired	Stage II clearance in progress
3	Trees in RoW	28,460 trees need to be enable road expansion	To be taken

### 6.2. Cost of environmental mitigation

The Environmental Mitigation and Management Costs were developed based on the estimation of resources required to implement the mitigation measures proposed and also number of places where intervention is required. Environmental mitigation cost for the proposed project is Rs. <xx> cr.

## 7. Social impact assessment and Land acquisition

### 7.1. Social impact assessment

The existing RoW (x-y m) is <adequate/ in adequate> for the proposed widening and RoW requirements as required by <NHAI/Authority>. This will lead to the additional acquisition of <xx>Ha across the states of <states1, 2>, affecting a total of <yy> villages in <zz> districts. In addition to structures found to be encroaching the current Row, the required acquisition is poised to affect <xx> residential and <yy> other structures.

Preliminary interactions have been held with locals to understand their issues and concerns and help communicate the project plan and its impact on them. The key concerns of title and non-title holders centered around:

- <Key issues expressed over and above land being acquired, and compensation norms>

### 7.2. Land acquisition requirements

The state and district wise details and status of land acquisition as on the date of publishing of this report is as follows:

**Table 23: Districtwise land acquisition requirements and status**

State	Village and Chainage	Total land required (Ha)	Private land to be acquired (Ha)	3A pending (Ha)	3A done, 3D pending (Ha)	3D completed
Maharashtra	Thane (xx to yy)	137	90	10	70	10
Gujarat	<aaa>	454	400	20	300	80
Gujarat	<bbb>	588	588	60	500	28
Gujarat	<ccc>	688	320	80	160	80

A total of <xx cr> is expected to be awarded for the acquisition of land required for this project. The land acquisition process is underway with a total of <xx> CALAs appointed, and 90% of land is expected to be in possession by <xx, 20xx>.

### 7.3. Key risks envisaged in land acquisition

Despite the best efforts of the consultant and various land acquisition teams working to complete land acquisition, it is envisaged that acquiring possession of the RoW for some specific sections of the project road may prove to be difficult or be delayed inordinately. Such potential risks are highlighted below:

- <Highlight any risks foreseen along with chainage and ha affected>



## 8. Utilities shifting and clearances

Utilities belonging to <x> user agencies have been identified that fall within the project road ROW and will need to be shifted to enable road construction. Shifting proposals have been submitted to the user agencies and initial estimates have been received from the concerned agencies. The process of site inspection, review and revision of the proposals for utilities shifting is in process.

<To enable better management of utilities and installation going forward, all utilities are being shifted underground/into a utility corridor/out of the road RoW/ utility trench is being planned as part of construction>

### 8.1. Utilities shifting estimates

**Table 24: Key utilities shifting requirements**

Sl No	Utility	Chainage affected	Agency	Shifting required	Estimated cost (INR cr)	Supervision %	Current status
1	66kV powerline	123.00-145.00	UPVVNL	19km of overhead cable, 4 road crossings	~140 cr	15%	Final approval obtained

### 8.2. Total cost of utilities shifting

The total cost of utilities shifting for all the utilities identified in the road RoW is estimated to be <xx cr> with supervision charges of <yy cr> being paid as supervision charges to the <z> concerned agencies.

## 9. Project cost estimates

The cost estimates for the project has been carried out based on detailed design, bill of quantities, and the schedule of rates for <state/district/authority> of year <xx-yy>.

**Table 25: Summary of project cost**

No	Item	Amount in Cr	Amount in %
	<b>Civil construction cost</b>		
1	Site clearance and dismantling	60	2%
2	Earth Work		
3	Base courses		
4	Paving courses		
5a	Repair and rehabilitation of structures		
5b	Bridges		
5c	Culverts		
5d	PUP/MUP		
5e	Flyover and overpass		
5f	Drainage, protective works and other services		
5g	RE/toe walls		
6	Junctions and interchanges		
7	Toll plazas		
8	User amenities		
9	Traffic signs, road markings, other appurtenences		
10	Miscellaneous		
11	Maintenance of road during construction		
<b>A</b>	<b>Total civil cost</b>		
12	Add contingencies @ x% on Z		
<b>B</b>	<b>Estimated project cost</b>		
13	Construction supervision @ x% on Z		
14	Agency charges @ x% on Z		
15	Quality control changes @ x% on Z		
16	Road safety cell audit charges @ x% on Z		
17	Maintenance costs @ x% on Z		
18	Escalation @ x% on Z		
<b>C</b>	<b>Total project cost</b>		
19	R&R cost		
20	Environment cost		
21	Cost of shifting utilities		
22	LA compensation cost		
<b>D</b>	<b>Total capital cost</b>		

## 10. Material investigation

Material investigations were carried out to explore the availability and identify sources of suitable material for the construction of the road.

<retain only relevant sections>

### 10.1. Borrow pits for soil

Material investigation of <xxx> locations indicates that soil suitable for embankment (of CBR>xx% and density yy g/cc) and for sub-grade (CBR>xx% and density yy g/cc) is available at an average lead of aa to bb km for the project stretch.

<include details on additional material sources like construction rubble, moorum etc>

### 10.2. Sand

Sand is available in <close proximity> of the project site. Test results show that xx of yy sand sources satisfy the minimum requirement for use in the project.

<Include details of additional potential for sources such as pond bed desilting, other excavation happening>

### 10.3. Gravel

Several quarries were identified for sourcing aggregates in the project zone. Xx of yy quarries were found to be suitable for use in the construction of the road. <further details on gravel available and suitability for construction>

### 10.4. Fly ash

Fly ash is available in close proximity of the project road due to the presence of <xx steel plant/power plant>. Test results show that the available fly ash <satisfies/does not satisfy> the minimum requirement of <specification> to use as <material for embankment/cement mixture/other layers>. The fly ash available has density greater than xx g/cc and shows an OCM of xx-yy%. <the fly ash located is non plastic>

### 10.5. Bitumen

Bulk bitumen of the <required grades> is available <closest sources> with an average lead of <xx km>. For the project road <grade> of bitumen has been proposed for <yy layer> due to <reason> and <grade of bitumen> has been proposed for <zz layer> due to <reason>.

### 10.6. Cement

Bulk bitumen of the <required grades> is available <closest sources> with an average lead of <xx km>. For the project road <grade> of bitumen has been proposed for <yy layer> due to <reason> and <grade of bitumen> has been proposed for <zz layer> due to <reason>.



### 10.7. Other local material available

Details of other local material available for construction

**Table 26: Locally available and alternative materials**

SI No	Material	Source
1	Hume pipes	Local hume pipe factory in xx yy
2	xx	xxxx

### 10.8. Key risks

Despite the best efforts of the consultant, there continue to be some materials and sections of the project road where material will have to be brought from significant leads.

**Table 27: Key risks envisaged in material procurement**

SI No	Chainage	Material	Closest source
1	Entire project	Bitument	Closest available source is Mumbai at a lead of 900 km
2	223.00+	Soil of CBR >10%	No borrow pit in vicinity, minimum lead of 40 km

### 10.9. Location of material sources

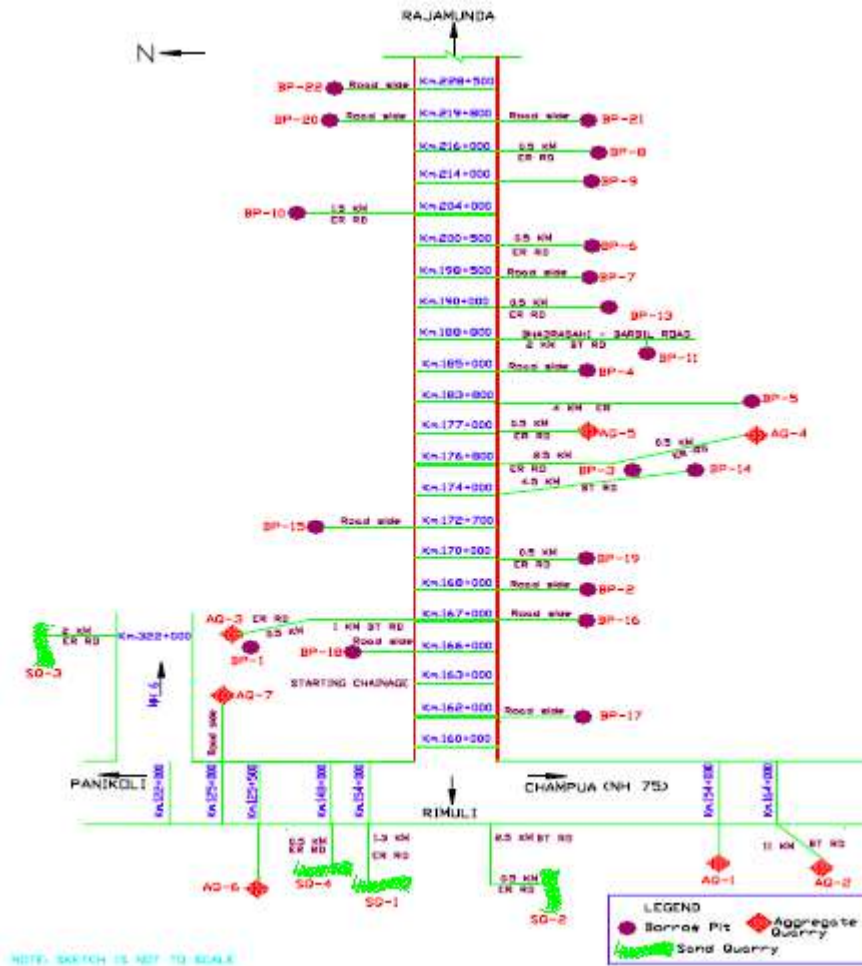

Figure 4: Key plan showing location of potential borrow pits tested

## 11. Potential for value engineering and innovative technologies

Throughout the detailed design of the project, several opportunities for value engineering and introduction of new technology were explored that will help in reducing the cost of the project or increase quality and longevity of project road. Approval of these elements as part of the construction design and suitable instructions to all stakeholders of the project can help significantly lower the projected cost of construction.

A summary of these opportunities is provided here.

**Table 28: Key value engineering opportunities identified**

SI No	Value engineering opportunity	Potential impact
1	Use of inverted pavement with a cement stabilized based and granular material in the base layer	40% reduction in layer thickness and ~15% reduction in TPC

## 12. Economic and financial analysis

### 12.1. Economic analysis of the project

The EIRR and NPV of the project has been carried out using <model/software> under multiple scenarios, and the project returns <justify/do not justify> construction given an EIRR of xx in the best case and yy in the worst case.

The various sensitivity scenarios considered were as follows:

0. Base case: Base cost and base benefits
1. Sensitivity 1: Base cost plus xx% and base benefits
2. Sensitivity 2: Xx
3. Sensitivity 3: Xx

The results of the base case and sensitivity analysis are presented below:

**Table 29: Economic return analysis**

Option	Sensitivity Case	RUCS		HDM 4	
		NPV (in million Rs.)	EIRR (in %)	NPV (in million Rs.)	EIRR (in %)
With time	Base Case 0	19199	30.31	2788.5	14.1
	Sensitivity 1	18041	27.51	1362.6	12.9
	Sensitivity 2	15147	27.1	943.3	12.8
	Sensitivity 3	13989	24.56	-ve	11.7
Without time	Base Case 0	19199	30.31	2788.5	14.1
	Sensitivity 1	18041	27.51	1362.6	12.9
	Sensitivity 2	15147	27.1	943.3	12.8
	Sensitivity 3	13989	24.56	-ve	11.7

### 12.2. Financial analysis

#### 12.2.1. Potential for toll revenue

The projected tollable traffic basis traffic survey and forecasts at the <xx> toll plazas suggested in year <xx> is given below

**Table 30: Tollable traffic on project stretch**

Toll Plaza	1 @ Chainage 45.000		2	
	Total	Tollable		
Traffic type				
Bicycle	47	0		
2 Wheeler	3320	0		
3 Wheeler	32	0		
Tractor	24	0		
Tractor with Trailer	389	385		
2 Axle SCV	436	386		
LMV 2 axle	3561	3545		
LCV 2 Axle	577	603		
2 Axle Truck or Bus	908	800		



3 Axle Truck or Bus	1142	1062		
Multi Axle Vehicles MAV	2033	1962		
Oversized Vehicle OSV	2	1		
Earth Moving Equipment	0	0		
AADT (in vehicles)	12471	6500		

### 12.2.2. Results of financial analysis

With the most likely traffic scenario and assumed costs of construction, maintenance, financing and tolling over the period of the project, the return on equity at various periods of concession was calculated. Equity IRR for this project will pass <15%> in year <x> of this project, hence it <is/is not> possible to bid the project

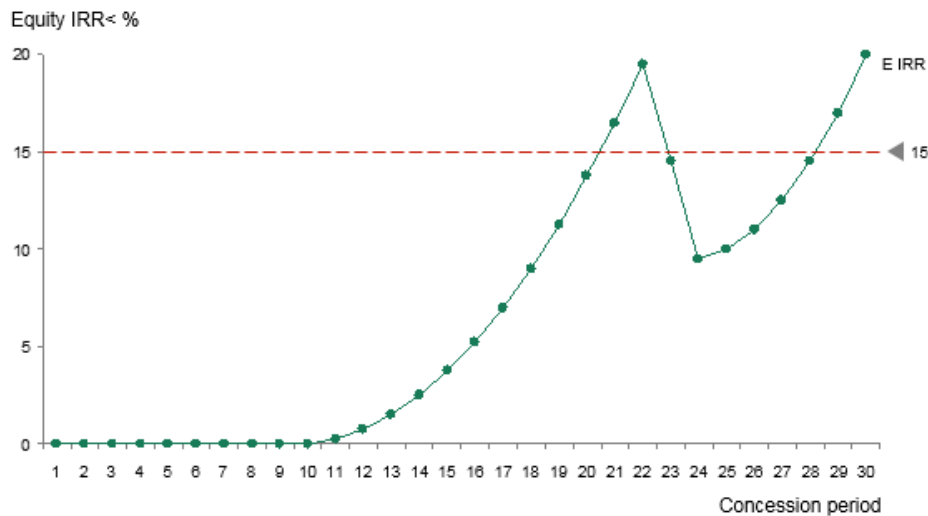

Figure 5: Equity IRR with increasing concession period for project road

## 13. Execution plan

In consultation with NHAI, it is proposed to complete the proposed project road in a period of <xx> months. Planning for the project packaging, bidding process and construction was conducted as a part of this project.

### 13.1. Packaging

Given the length of the project, the entire project is planned to be bid out in <xx> packages with <yy> packages.

<include table of package details if more than 1 package>

### 13.2. Bidding mode and timelines

The authority has proposed to initiate bidding of the project under <bot/epc/ham> mode <with a grant/premium of xx %>. The tentative timeline for this is:

- Submission of bid documents to authority dd/mmm/yyyy
- Review and finalization of documents dd/mmm/yyyy
- Launch of tender dd/mmm/yyyy
- Tender close date dd/mmm/yyyy
- Tentative date for award of project dd/mmm/yyyy

### 13.3. Construction time and planning

Upon reviewing the improvements planned and in consultation with NHAI, the design and construction period for this project has been arrived at <xx> months from the date of appointment of the contractor/concessionaire. To enable this construction schedule, a detailed construction plan and timeline has been included in the detailed project report. This also includes a traffic management and lane closure plan for the period of construction.

## 14. Conclusions and recommendation

The <expansion/rehabilitation> of the project road from <source> to <destination>, chainage <a> to <b> on NH <x> in the states of <state 1, state 2> to <n> lane configuration is recommended for implementation by NHAI as the project is likely to <1 line justification/ need of project: provide much needed connectivity/improve connectivity/provide higher level of service/rehabilitate the road etc, is needed urgently>.

The project as envisaged is economically viable with an estimated EIRR >12%. The project with a 30 year concession period is expected to return an equity IRR of <xx%> with <yy%> <grant/premium> and is hence recommended for implementation in the <BOT/EPC/HAM> mode.

**Table 31: Salient features and key financial aspects of the project road a**

Project road		
Project road length	Xx km	
Connecting	<origin>- <destination>	
On national highway	NH No	
Proposed features	Current road	Proposed
Lanes	2	4
Bypasses proposed	-	5
Major junctions	5	5
Minor Junctions	18	18
Grade separated interchanges	1	4
Major Bridges	4	6
Minor Bridges	19	21
ROBs	1	3
Culverts	120	200
Vehicle/Pedestrian under/overpasses	16	25
Service roads (kms)	14	32
Slip roads (kms)	8	9
Toll plazas (no)	-	2
Bus bays (no)	4	15
Truck lay-byes (no)	2	8
Rest areas (no)	2	6
Financial implications	INR Cr/%	
<b>Total capital cost</b>	<b>1595</b>	

<b>Total project cost</b>	<b>1486</b>
Civil construction cost (incl. contingency)	1249
<b>Preconstruction expenses</b>	<b>110</b>
Land acquisition	40
Utilities shifting	30
Rehabilitation and resettlement costs	20
Other pre-construction expenses	20
Implementation mode proposed	BOT (Toll)
Total project cost	1486
Concession period	18 years
<Authority> support (Grant/Premium)	18%
Estimated NPV	50
Project IRR	12%
Equity IRR	15%