

Article Type: Original Article

Corresponding Author:

Jonathan D Howard, Rehabilitation Engineering Unit, Medical Physics & Clinical Engineering, Morriston Hospital, Swansea, SA6 6NL, United Kingdom.

Email: Jonathan.Howard2@wales.nhs.uk.

Article Title:

Evaluating additive manufacturing for the production of custom head supports: A comparison against a commercial head support under static loading conditions

Authors

Jonathan D. Howard¹. Dominic Eggbeer². Peter Dorrington³. Feras Korkees³. Lorna H Tasker¹.

¹Rehabilitation Engineering Unit, Medical Physics & Clinical Engineering, Morriston Hospital, Swansea, UK

²PDR, Cardiff Metropolitan University, Cardiff, UK

³College of Engineering, Swansea University, Swansea, UK

Abstract

The provision of wheelchair seating accessories, such as head supports, is often limited to the use of commercial products. Additive manufacturing has the potential to produce custom seating components, but there are very few examples of published work.

This paper reports a method of utilising 3D scanning, computer aided design and additive manufacturing for the fabrication of a custom head support for a wheelchair. Three custom head supports, of the same shape, were manufactured in nylon using a continuous filament fabrication machine. The custom head supports were tested against an equivalent and widely used commercial head support using ISO 16840-3:2014. The head supports were statically loaded in two configurations, one modelling a posterior force on the inner rear surface and the other modelling a lateral force on the side. The posterior force resulted in failure of the supporting bracketry before the custom head support. A similar magnitude of forces were applied laterally for the custom and commercial head support. When the load was removed, the custom recovered to its original shape while the commercial sustained plastic deformation. The addition of a join in the head support increased the maximum displacement, 128.6 mm compared to 71.7 mm, and the use of carbon fibre resulted in the head support sustaining a higher force at larger displacements, increase of 30 N.

Based on the deformation and recovery characteristics, the results indicate that additive manufacturing could be an appropriate method to produce lighter weight, highly customised, cost-effective and safe head supports for wheelchair users.

Keywords:

Additive manufacturing, 3D printing, wheelchairs, custom seating, rehabilitation engineering

Introduction

The seating requirements for the majority of wheelchair users in the UK are able to be met using off-the-shelf seating systems and equipment. However, a small percentage of wheelchair users require more customised solutions [1]. Customised solutions involve modifications to off-the-shelf components or the manufacturing of bespoke equipment [2]. There are well-established techniques for the creation of bespoke wheelchair seat and backrest cushions through a process known as custom contoured seating, which are moulded to fit the anatomy and anthropometry of the user [3-4]. The latest advancements in custom contoured seating combine three dimensional (3D) scanning, Computer Aided Design (CAD) and Computer Numerically Controlled (CNC) machining to create foam cushions [5]. However, there are limited standardised methods for the provision of other custom postural support accessories for wheelchairs.

A postural head support is often required for wheelchair users [6]. A head support prevents over extension of the neck caused by muscle stiffness or weakness, fatigue or extensor spasms [7]. It also supports the head when the wheelchair is tilted or reclined. The head's position can be critical for breathing, swallowing and feeding [5]. It also impacts on the user's field of vision; this is functionally important for their interaction and communication with people and the environment [8]. Head support designs vary depending on the users' requirements from relatively simple occipital support at the back of the head to more complex sub-occipital support, lateral head support. These support the side and back of the head. Important factors to consider for head support design and provision identified in the literature by Pope (2007) [7] & Appleyard *et al* (2013) [6] include:

- Avoid covering the ears and eyes. Covering the ears can cause pressure damage and reduce hearing. Covering the eyes reduces visibility impacting on communication;
- Be positioned above the most prominent point on the back of the head and as close to the back of the head as possible;
- Firmly attached to the seating system;
- Withstand a substantial horizontal load to the frontal contact surface if the head support is intended for use in transportation.

Current commercial complex head supports cannot always meet both the shape and strength requirements for wheelchair users. Whilst many commercial products have reasonable adjustability in shaping the head support, adding adjustability within the product adds an inherent mechanical weakness to the design. Secondly the shaping of many commercial products is often limited with

avoiding contact over the user's ear and supporting the occiput. Therefore, some wheelchair users would benefit from bespoke options.

Additive manufacturing (which is also widely known as 3D printing) is well suited to the production of products that are highly personalised or bespoke, with no additional costs needed for the customisation of parts [9-10]. Additive manufacturing is already extensively used by other medical specialties, including surgery and dentistry [11-16], prosthetics and orthotics [17-19]. Cited benefits of additive manufacturing include high degrees of design freedom, opportunity to reduce component count and weight, enablement of on-demand and close to point of care services and reduced cost compared to alternative manufacturing methods [20-21].

Given the benefits of additive manufacturing cited in other medical applications it is believed that it could be a useful production technique for custom wheelchair accessories. A state of the art review on custom contoured seating for wheelchairs concluded that additive manufacturing may reduce costs, improve lead times and enable greater micro-climate control compared to current manufacturing methods [22]. In addition, additive manufacturing may enable greater design freedom for wheelchair seating accessories such as head supports compared to current commercial products. A literature review carried out in preparation for this research found no published research reporting on the production and testing of additive manufactured wheelchair accessories.

Head supports are subject to high loads and could pose a risk to user safety if they fail in an unsafe manner. Therefore it is essential to understand the mechanical failure characteristics of additive manufacturing produced head supports and to compare these with current commercial head supports before trialling with users.

This paper first reports a developed workflow that could be utilised by healthcare wheelchair and specialist equipment providers based on current techniques used in providing custom wheelchair equipment. The workflow utilises 3D scanning, 3D CAD and additive manufacturing for the fabrication of a custom head support for a wheelchair. Secondly this study reports the results of comparative mechanical testing of an additive manufactured head support against an equivalent and widely used commercial head support.

Materials and Methods

Head support design and manufacturing

Figure 1 provides a high-level overview of the design to manufacture process.

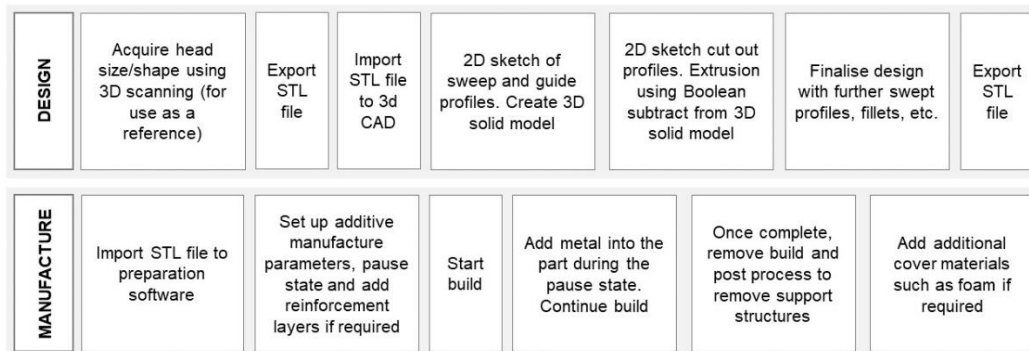

Figure 1: Overview of the design to manufacture process for the custom head support.

A 3D scan of a volunteer's head was obtained using a Kinect hand-scanner for Windows (version 1, Microsoft Inc., USA) with Artec studio 9 (Artec3D, Luxembourg). This was used to produce a StereoLithography (STL) file, which became and is still the de facto standard for most types of additive manufacturing input [23]. The 3D head scan formed the template shape around which the head support was designed.

The head support was customised in shape to match the occiput of the volunteer's head and provide left sided lateral support, whilst avoiding contact with the ear (Figure 2 top). Autodesk Fusion 360 (July 2018) 3D CAD software (Autodesk Inc., USA) was used to design the head support:

- A two dimensional sketch profile, curved to match the shape of the occiput and sub-occiput, of thickness 8 mm was swept along a second sketch curve outlining the circumference of the head. Sweeping is a CAD process which allows a complex curve to follow a rail or 3D line.
- An additional curve of 15mm thickness, profiled as previous, was swept along 40% of the circumference curve, adding additional depth around the occipital.
- Extrusion cuts removed the area of support covering the ear and a cuboid of dimensions 60mm x 38mm x 9 mm from the back section, offset 10 mm from the rear surface and 35 mm from top; this allowed an aluminium cuboid to be inserted and fully encapsulated into the additive manufacture build.
- A final extrusion cut removed three 5 mm holes from the rear surface to the previous cut-out. These holes aligned with M5 holes in the aluminium cuboid (Figure 2 bottom left) and allowed for the head support to interface with standard RMS wheelchair bracketry (Rehabilitation Manufacturing Services Limited, UK).

- A swept cut removed a dome of radius 10.5 mm, depth 7 mm, from the centre of the three 5 mm holes. Five support structures supported the dome whilst printing.
- Fillets reduced any sharp edges on the head support.

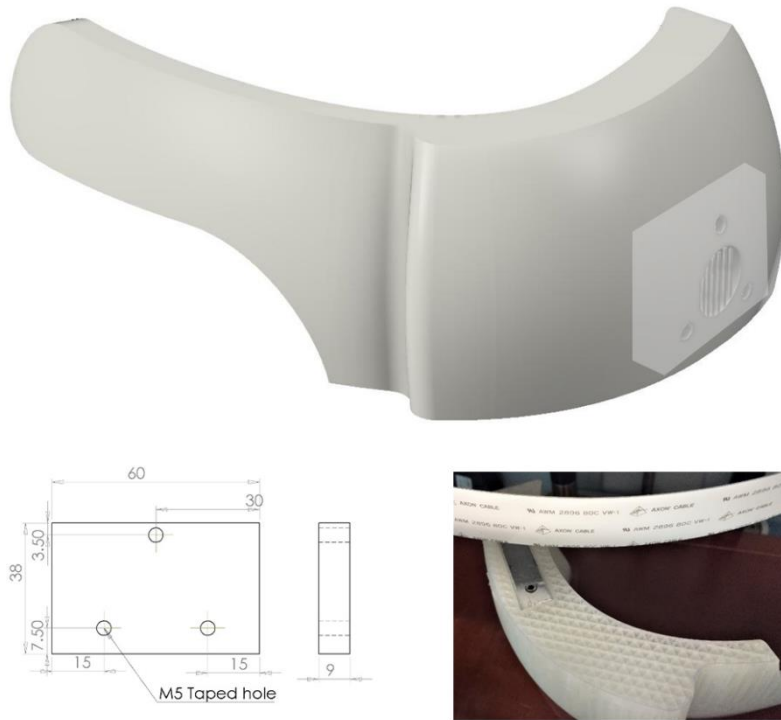

Figure 2: Top: Rendered CAD model of custom head support, grey area indicated location of aluminium cuboid insert.

Bottom left: Engineering drawing of aluminium cuboid insert. Bottom right: Aluminium cuboid inserted into the head support during pause state of manufacturing.

For the purpose of this study, the height and width of the full head support were reduced to create a design which fitted into the chosen print bed (320 mm x 132 mm x 154 mm) as a single piece. The completed design was exported as an STL file using high quality settings: surface deviation 0.0126 mm, normal deviation 10, maximum edge length 252.79 mm, aspect ratio 21.500 (number of triangles 32946).

The Markforged Mark Two (Markforged Inc., USA), a Continuous Filament Fabrication (CFF) type machine, was chosen for fabrication due to being relatively affordable, having a small size footprint and requiring minimal post-processing equipment compared to other large format industrial systems. This would potentially make it more applicable to a healthcare environment. It is also one of few machines that allows a pause state where a build platform can be temporarily removed from the machine, inserts placed within the build volume, then the platform replaced before the build is

continued. The nylon build material can also be reinforced with carbon fibre/fibreglass/Kevlar to tailor mechanical properties. Nylon was used primarily due to its toughness, which is owed to its malleability and high impact resistance compared to other common low-cost Fused Deposition Modelling (FDM)/CFF materials (such as polylactic acid, acrylonitrile butadiene styrene and polyethylene terephthalate glycol). These properties were predicted to offer failure characteristics that would be unlikely to leave sharp edges.

Proprietary Eiger software (Markforged Inc., August 2018 version) was used to orientate the components with a flat face on the bottom, brim setting on to prevent warping on the print bed, 0.125 layer thickness (used when adding carbon fibre reinforcement), supports at 45° to x-axis, 4 layers for roof and floors, 2 wall counts and 37% triangular fill density. The triangular pattern was considered to provide the greatest resistance to deformation caused by loading of the head perpendicular to the headrest surfaces. A higher number of wall counts, different infill patterns and infill densities can be used, but these affect the build time and risk of part warpage (a potential problem with CFF manufacturing processes). Therefore, manufacturer refined defaults were used, acknowledging that parameter adjustment could be the focus of future studies. A 'pause' state was added at 72.875 mm, where the cut out feature for the aluminium cuboid finished.

In the 'pause' state, the platform, with the part attached, was removed from the machine to allow the aluminium cuboid to be inserted. The support was removed from the cut out cavity using long nose pliers, and the aluminium cuboid was tapped into the cut out using a rubber mallet, ensuring it was flush with the upper surface of the build layer. If the aluminium protruded above the build layer, the extrusion head would foul, causing damage to the machine and build. The platform was then returned into the machine and the manufacturing continued (Figure 2 bottom right).

The first successful build illustrated the potential to fabricate a head support with an integrated aluminium cuboid, which allowed attachment to standard wheelchair components. However, although it was only half size, it took up nearly the entire build volume of the Mark Two machine; it would not be possible to fabricate a full head support in one piece using this machine. It was therefore essential to evaluate whether it was feasible to fabricate an entire head support using assembled sections and whether this would affect mechanical performance. A novel press fit, sliding interlocking feature was designed into the thicker part of the head support (Figure 3 top left & right) and was extruded down 90% of the total height.

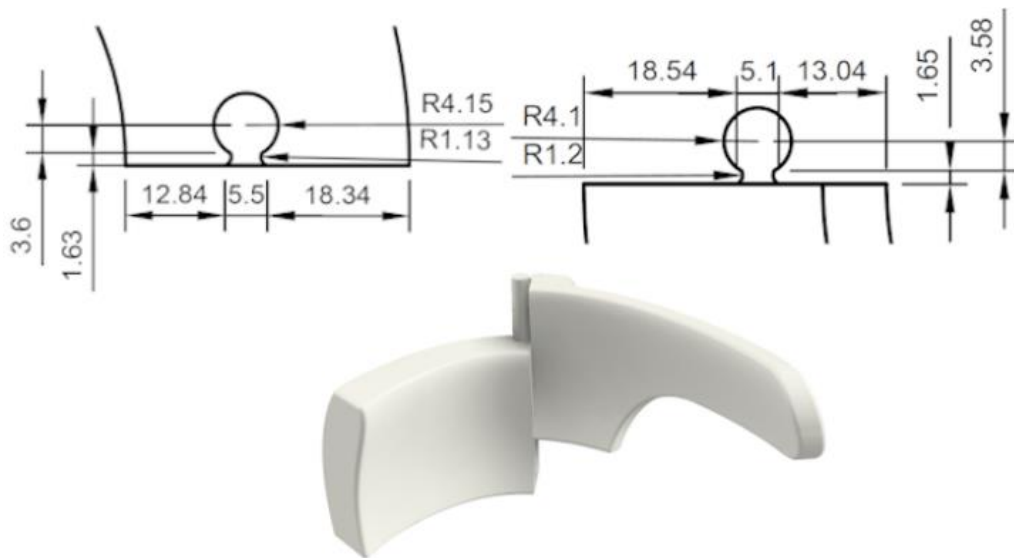

Figure 3: Top left: 2D drawing of interlocking feature on central component. Top right: 2D drawing of interlocking feature on lateral component. Bottom: Rendered CAD model of joint head support.

Given the potential for joints to introduce points of mechanical weakness into the design, the effect of adding fibre reinforcement was also evaluated. Layers of concentric carbon fibre reinforcement were added using the preparation software, Eiger. Concentric was chosen based on the need to balance the use of carbon material with potential to increase stiffness – it was perceived as more important to strengthen the joint area, which a concentric pattern of carbon would suffice. Three layers were added to the lateral component at the top, middle and bottom of the component using 3x concentric fibre walls (Figure 4 left). Two layers were added to the central component at the top and bottom using 3x concentric fibre walls (Figure 4 right). The Mark Two embeds a filament of carbon fibre into the nylon at the layers and in the pattern defined in the Eiger preparation software.

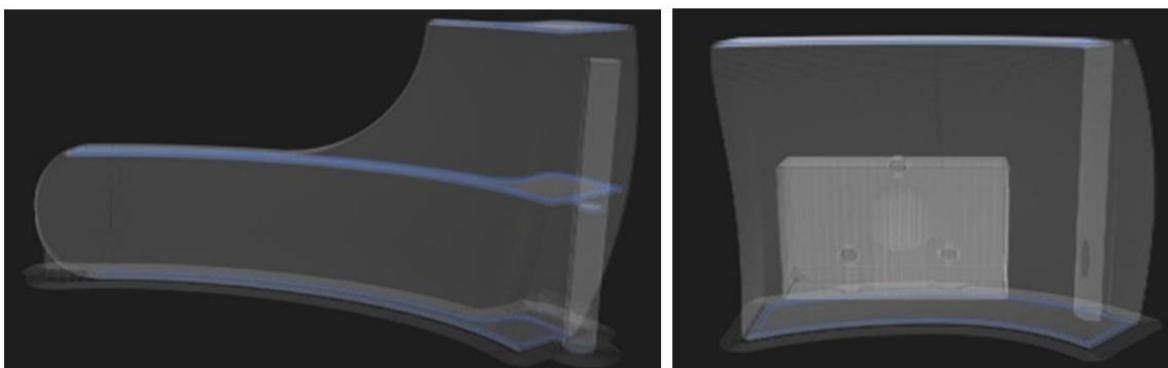

Figure 4: Left: Eiger screenshot of lateral component showing location of carbon fibre layers. Right: Eiger screenshot of central component showing location of carbon fibre layers.

A total of four parts were produced: two full head supports from nylon only, one head support with joint from nylon only and one head support with joint and carbon fibre reinforcement.

Testing set up and procedure

The custom head supports were tested against a commercial head support, the Type-G by RMS (Figure 5 top). The Type-G has adjustable finger sections which can be adjusted to change the curvature shape, providing lateral support. It uses a ball mount stem bracket and a 90° stem bracket to interface with wheelchair backrests. The same bracketry was used for the additive manufactured head supports during testing.

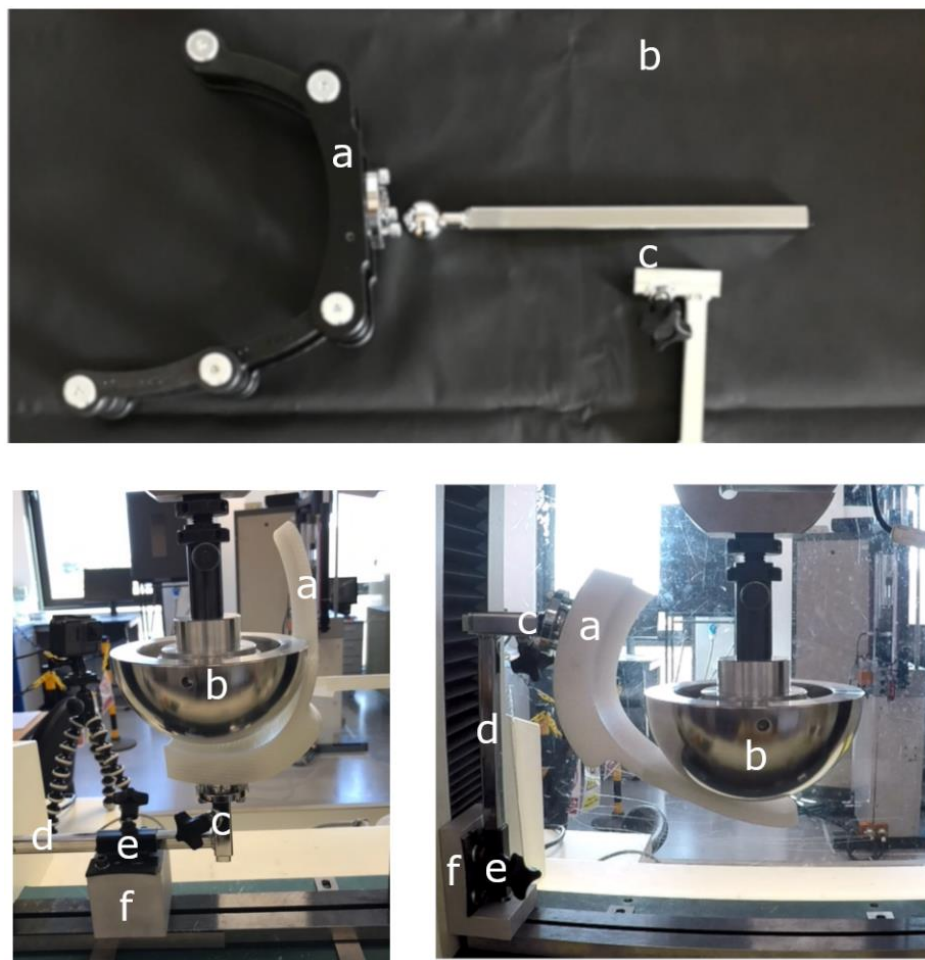

Figure 5: Top: a) Type G head support by RMS, b) Ball mount stem bracket by RMS, c) 90° stem bracket by RMS, used for interfacing to wheelchair backrest.

Bottom left: test set up for posterior loading test for. Bottom right: test set up for lateral load testing. Parts: a) Custom head support. b) Hemispherical 75 mm radius loading pad, aluminium. c) Ball mount stem bracket, from RMS. d) 90° stem bracket, from RMS. e) Multi point fixing bracket, from RMS. f) Jig block, aluminium, for interfacing with loading machine.

The mechanical testing followed the protocol set out in ISO 16840-3:2014 “Wheelchair seating, Part 3: Determination of static, impact and repetitive load strengths for postural support devices” [24]. All tests used a calibrated Hounsfield H25KS (Tinius Olsen, US) machine fitted with an aluminium convex hemispherical loading pad of radius 75 mm. Load was applied at a controlled strain rate of 10 mm/min. Two static tests were relevant; the first test applied a posterior force to the inner rear surface (Figure 5 bottom left). This test was performed on one of the full additive manufactured head supports. Failure was predicted to be around the bracketry. Since the bracketry was the same for both the additive manufactured and Type-G, only testing on the additive manufactured head support was deemed necessary.

The second test represented the application of a lateral force to the inner surface of the left lateral support arm (Figure 5 bottom right). Preliminary testing positioned the head support at 90° to the ball joint. Through reviewed video recordings of the testing, it was confirmed that the displacement was due to the movement of the ball joint. From the force-displacement graph alone, it was difficult to distinguish between ball joint movement and head support deformation.

The test protocol was modified to pre-displace the ball joint to the maximum displacement prior to the load being applied. This ensured the displacement measured was deformation of the head support only. This test was performed on the Type-G, the full additive manufactured head support and the two additive manufactured joint head supports (with and without carbon fibre). The joint head supports were only subjected to the lateral force test as it was expected the joint would not affect the mechanical properties for the posterior force test. The load was applied until either the head support failed; the bracketry failed; or the maximum range of the Hounsfield machine was reached. The force and displacement of the loading pad were recorded every 0.5 seconds. Video recordings were taken of all tests. Due to resources limitations, no repeat tests were performed.

Results

Posterior force testing

The maximum force reached was 3188.0 N at a displacement of 50.0 mm (Figure 6, label c). The maximum displacement reached was 71.7 mm, force of 543.0 N. From observation the point of failure of the head support was the 90° stem which bent around the aluminium jig block (Figure 6 label d). Up to 11.0 mm (2500.0 N), the deformation in the bracketry was in the elastic region (Figure 6, label b), however past 11.0 mm striations started to appear in the bracketry (Figure 6, label b-c). Past 50.0 mm, the force required to deform the head support decreased until failure at 72.0 mm

(500.0 N). Deformation of the ball joint was also observed between 10.0 and 50.0 mm. Upon completion of the testing, the additive manufactured head support was visually inspected and no permanent deformation was visible.

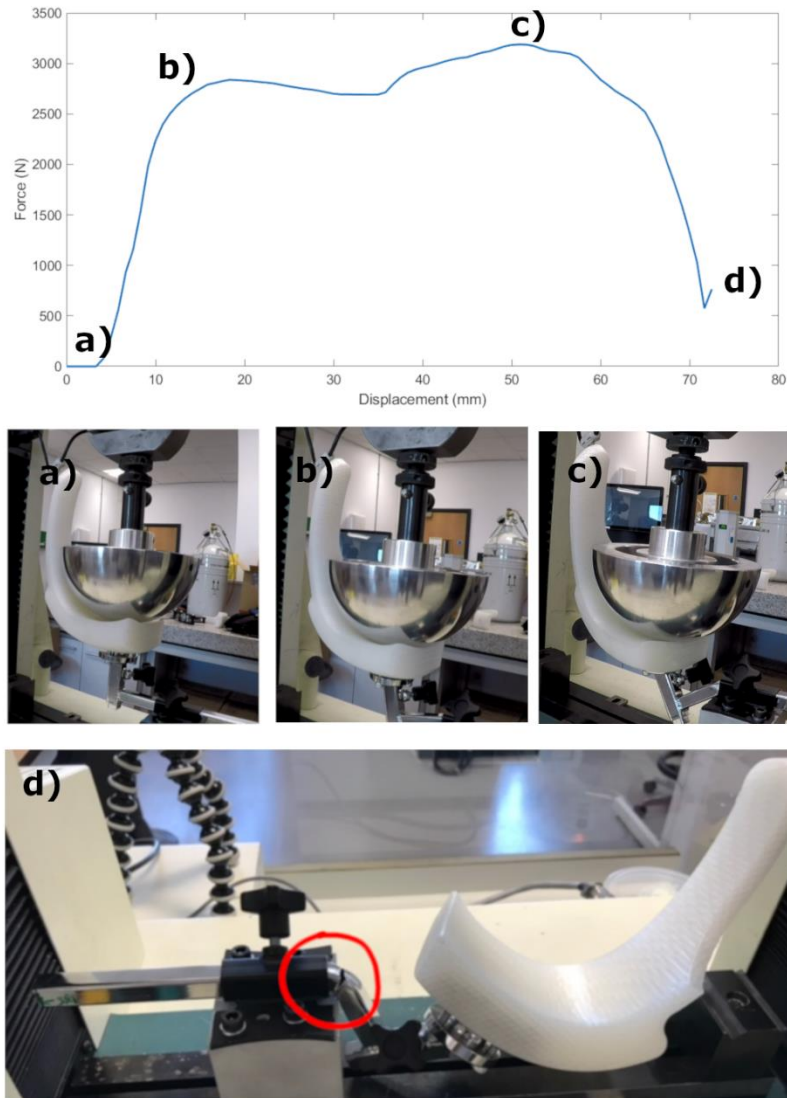

Figure 6: Force vs. displacement graph for posterior force test with corresponding photos at key identified points. a) Before load applied, b) after displacement of 10mm, c) after displacement of 50mm, d) once load removed, red circle indicates failure of test set up on the 90° stem bracket

Lateral force testing – neutral ball joint

Initially the force increased linearly with displacement of the head support up to 50.0 N at 12.0 mm displacement (Figure 7, label b). Past this a relatively constant force of 43.0 N was required to displace the head support at the 10 mm/s strain rate, up to a displacement of 57.0 mm (Figure 7, label c). From observation this initial displacement was due to the rotation of the head support

around the ball joint. The force increased to 70.0 N at a displacement of 78.0 mm (Figure 7, label d) before decreasing slightly to 60.0 N at 92.0 mm displacement (Figure 7, label e). From observation this was due to further rotation around the ball joint and deformation of the head support. The force increased to a maximum of 93.0 N at a displacement of 125.0 mm (Figure 7, label f), before decreasing to 85.0 N at maximum displacement of 143.7 mm (Figure 7, label g). From observation this was due to deformation of the head support only. Past this displacement the head support had deformed such that it was now parallel to the loading direction and hence no longer able to deform, testing was stopped. Upon releasing the load, the head support returned to original shape and no plastic deformation was visible (Figure 7, label h).

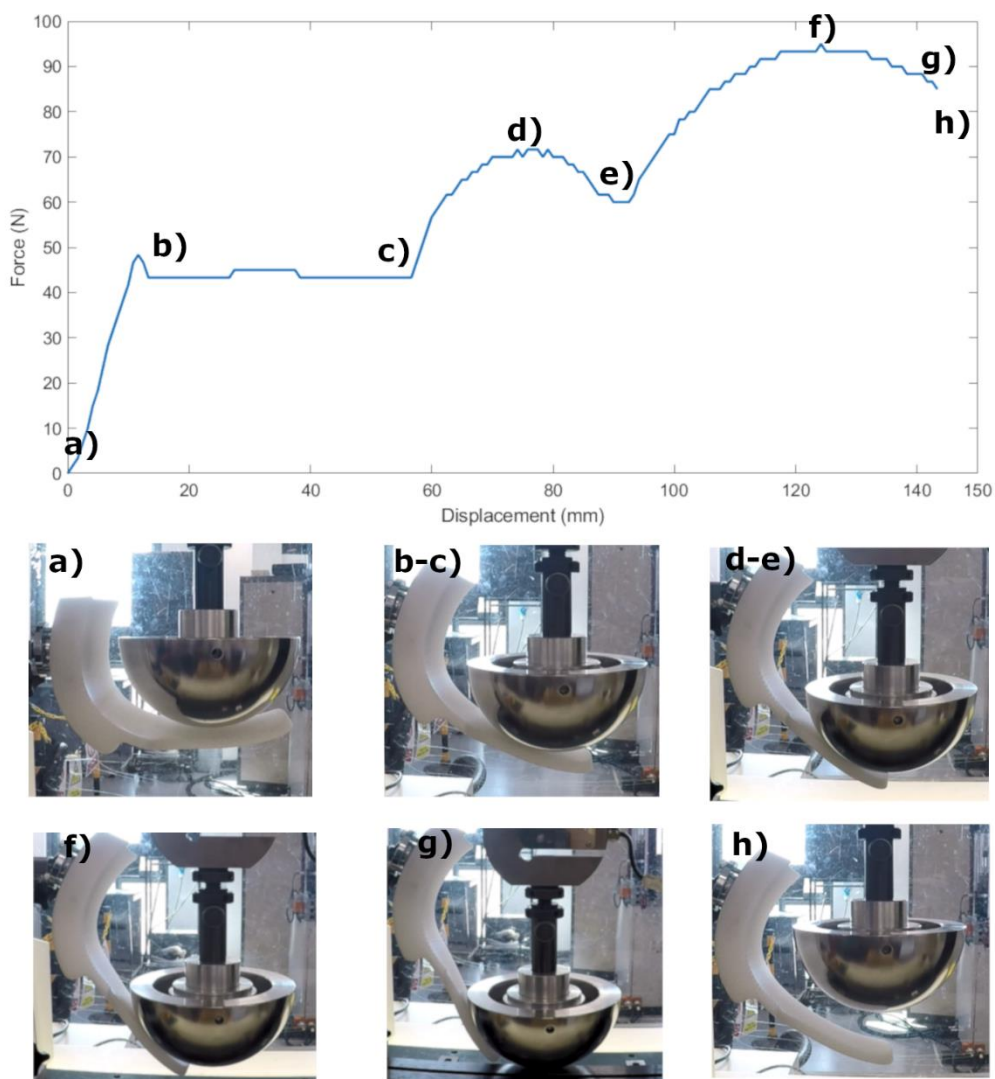

Figure 7: Force vs. displacement results for lateral force testing on full custom head support with ball joint set at 90° , with corresponding photos at key points. a) pre loading, b-c) displacement due to rotation of the ball joint, d-e) displacement due to further ball joint rotation and head support deformation, f) displacement due to head support deformation, g) maximum displacement reached, h) head support once unloaded with head support undeforming.

Lateral force testing – pre-displaced head support

Table 1: Summary of maximum force and corresponding displacement and maximum displacement and corresponding force for all head supports tested in lateral force testing with ball joint fully extended.

Head support	Max Force applied (N)	Displacement at max force (mm)	Max displacement reached (mm)	Force at max displacement (N)
Type-G	65.0	12.2	77.6	43.3
Custom full head support	80.0	55.3	71.7	71.7
Joint head support	98.3	41.2	128.6	28.3
Joint head support with carbon fibre	98.3	90.8	147.8	58.0

The maximum force applied to the Type-G was 65.0 N at a displacement of 12.2 mm (Table 1). Beyond this displacement, the force required to displace the head support was maintained, until 40.0 mm where the force required decreased (Figure 8). The maximum displacement was 77.6 mm, beyond this displacement the loading pad was no longer contacting the head support and testing was stopped. The deformation was due to the rotation of the finger sections around the joints. When the load was removed the head support maintained its deformed position.

The maximum force applied to the additive manufactured full head support was 80.0N at a displacement of 55.3 mm (Table 1). The maximum displacement was 71.7mm, past which the loading pad was no longer contacting the head support. When the load was removed, the head support recovered back to its original shape and from visual inspection no plastic deformation or cracks were present.

The maximum force applied to the joint head support was 98.3 N at a displacement of 41.2 mm (Table 1). Past this displacement, a decreasing force was required until a maximum displacement of 128.6 mm was reached (Figure 8). Past this displacement the loading pad was no longer in contact with the head support. When the load was removed, the head support recovered back to its original shape. Visual inspection confirmed that no plastic deformation or cracks were present.

The maximum force applied to the joint head support with carbon fibre was 98.3N at a displacement of 90.8 mm (Table 1). Prior to reaching this maximum force, the force increased with increasing displacement up to 60.0 mm at which point the force decreased from 90.0 N to 65.0 N (Figure 8). After this the force increased again until the maximum force was reached. Past the displacement at the maximum force, the force decreased until a maximum displacement of 147.8 mm was reached. At this displacement the head support failed at the joint and the two parts of the head support separated.

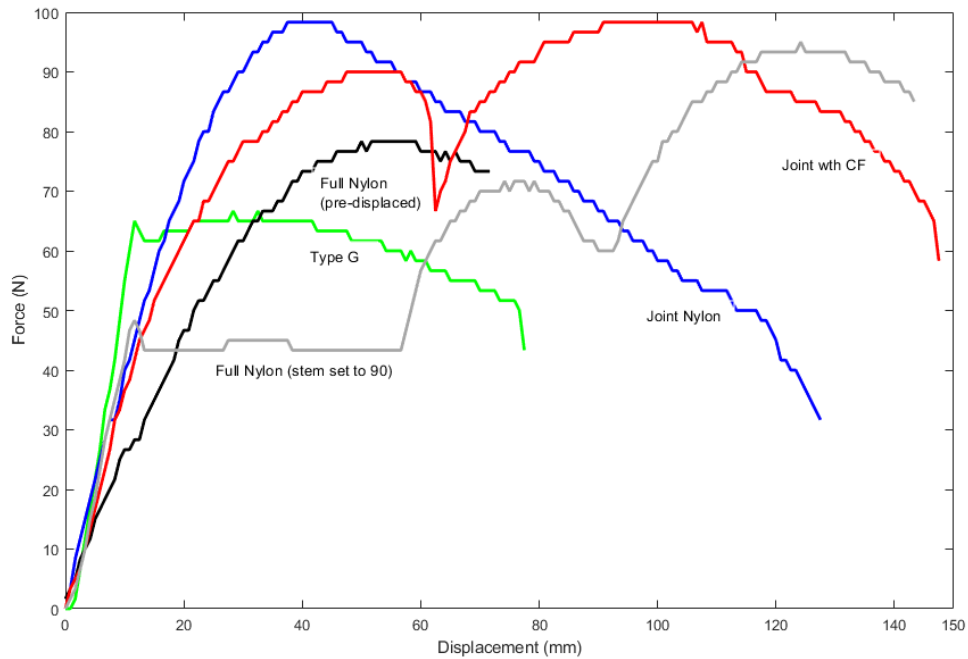

Figure 8: Results for all the head supports for lateral force testing with ball joint pre-displaced. Green: Type G, Black: Full nylon, Blue: Joint nylon only, Red: Joint with carbon fibre. Grey: Full nylon head support with ball joint set at 90°.

Discussion

Posterior force

The posterior force test represents the loading on the inner surface of the head support by the posterior aspect of the wheelchair user's head. Results showed that failure occurred at the bracketry (Figure 6), due to the bending of the 90° bracket around the aluminium jig block. This was predicted as the direction of the force produced a bending moment around the jig whilst being parallel to the head support bracketry joint. These results highlight that the head support, additive manufactured or commercial, would not influence the failure mechanism under posterior loads. This bracketry is standard equipment for wheelchairs; therefore, the use of additive manufacturing over a commercial head support would not be likely to impact system safety.

Lateral force –ball joint set at 90°

The lateral force test replicates the loading from the wheelchair user through the lateral (side) aspect of the head. The observation from this test was that the head support rotated around the ball joint prior to any deformation occurring to the head support itself (Figure 7, label a-b). This implies the weakest part of the system was the ball joint. After the ball joint reached its maximum displacement, the head support deformed. A greater displacement was achieved with the stem initially positioned perpendicular to the posterior head support surface (Figure 7, label a) compared

to when the ball joint was pre-displaced at its maximum position (Figure 8). Through reviewed video recordings of the testing, it was confirmed that the displacement was due to the movement of the ball joint.

Type-G vs full additive manufactured head support

The loading and unloading stages of the testing were both analysed to explore the clinical relevance of a single loading/unloading cycle. For the Type-G head support the maximum force, 65.0 N (Table 1), was reached at a lower displacement of 12.2 mm; comparatively the force at this displacement for the additive manufactured head support was only 25.0 N (Figure 8). This implies that, the Type-G requires initial greater forces to deform, when compared with the additive manufactured head support. Beyond a displacement of 10.0 mm the force applied to the Type-G remained near constant up to a displacement of 40.0 mm before the force decreased, whilst the force applied to the additive manufactured head support increased up to the maximum of 80.0N at 55.3 mm (Figure 8). The mechanical characteristics of the Type-G past 10.0 mm are due to the joints loosening for the head support, which allowed the finger sections to rotate and deform. Comparatively, the additive manufactured head support characteristics still showed a near linear increasing force with displacement implying the deformation was still within the elastic region of the material. During unloading, the additive manufactured head support recovered to its original shape, implying that elastic limit of the material had not been reached. In comparison the Type G head support stayed deformed. This result is clinically relevant since it indicates that an additive manufactured head support could recover to its original shape and therefore continue to provide support even after being loaded. When the Type-G becomes deformed, a seating clinician would be required to adjust the support.

As the additive manufactured head support deformed under similar loads to the Type-G (Figure 8), the results provide some assurance that a nylon additive manufactured head support could behave comparatively to a conventional commercial head support when subject to real-world posterior and lateral loads. During the unloading stage, the recovery characteristics of the additive manufactured head support may actually provide advantages over currently available supports. The failure mechanism of the additive manufactured head support would be expected to be a long elongation ductile failure, instead of a sudden brittle failure. This study however did not evaluate whether the additive manufactured head support had any non-visible internal damage, which could cause weakening and failure after cyclic loading.

Change of design parameters

For the joint nylon support, both the maximum force and the maximum displacement increased compared to the full support (Figure 8). This increase was partly due to a visible gap at the joint between the two sections. The increased force was unexpected, but an explanation could be due to an impingement of the joint initially preventing the two parts from separating. After the maximum, the force reduced implying the head support had exceeded the elastic limit of the material. However, as with the full version, after the load was withdrawn the head support recovered to its original shape. A slight loosening of the joint was observed implying plastic deformation around the interface of the joint. The testing did not assess the impact of repetitive loading/unloading of the head support over a long period of time. This could result in fatigue in the material, which could result in further weakening around the joint.

It was expected the carbon fibre would increase the load required to deform the head support due to the increased overall stiffness of the material through the matrix-fibre loading pattern of composites [25]. The testing results indicate the carbon fibre only improved the strength above a displacement of 68 mm (Figure 8). Whilst the additional strength would appear beneficial, as it was only recorded at larger displacements, there may be limited clinical benefit. Clinically, displacements over 68.0 mm could mean that insufficient support is being provided to the head, therefore the ability to provide greater strength through design optimisation should be explored in parallel to the addition of reinforcing materials such as carbon fibre. Failure did occur in the carbon fibre head support via a separation at the interlocking joint. Post testing, the two sections were reassembled and no plastic deformation was observed, similar to the other single piece additive manufactured version. Whilst the carbon fibre appeared to add strength, this study was not able to confirm the degree to which this could be clinically significant.

Research Limitations

This study was developed as an early stage, practical step towards reviewing the potential application of additive manufacturing for rehabilitation engineering, using head supports as a case study. It was not technically or financially feasible to consider repeat mechanical testing or a large range of alternative designs at this stage of development, thus there is wide opportunity for further research and development. Some specific limitations are worth discussing further.

This paper reports on a small number of variables associated with the additive manufacture of head supports and the impact these have on mechanical performance. There are, however, almost infinite variables in the design and manufacturing process, and materials. Thus, this work provides a step

towards identifying which design/manufacture variables are desirable and how they may be tested. For example, removing the need to insert a metal block during a paused build would simplify the process and reduce cost. Changing the carbon layering in strategy from concentric to isotropic, the number reinforced layers, etc. could all be explored to optimise the mechanical properties. Furthermore, evaluating alternative materials, such as Onyx, a chopped carbon filled nylon (Mark Forged Inc, USA) could help identify more efficient ways to improve mechanical performance.

A further limitation was that only one commercial head support was used for the testing, the Type-G. Future research could compare the results to other commercial products. By using ISO testing methods and describing design and testing protocols here, we hope to enable replication and development of this study against other commercially available head supports and computer-aided alternatives.

This research followed protocols defined in ISO 16840:3-2014. This ISO standard does not define a pass/fail force for compliance and therefore, based on current results, the safety of the additive manufactured head support was assumed based on equivalence or superiority to the Type-G head support only. It was also difficult to relate the results from the testing to the forces a head support may experience in clinical use; data quantifying the forces exerted by the head on a head support was outside the remit of this paper. Furthermore, all the links and bolts were hand tightened in accordance with manufacturer guidelines, however for future experiments, it would be important to control the torque applied to eliminate a variable in the testing.

The reported research also had practical limitations. The limited bed size of the chosen Markforged Mark Two additive manufacturing machine meant that it was not possible to fabricate an entire head support in one piece. This has potential advantages and limitations. Whilst a machine with a larger print bed would be beneficial for fabricating parts in one piece, such machines would have a higher capital cost. However, fabrication in multiple modular sections could enable agile manufacturing that makes use of multiple, smaller and lower cost machines whilst also allowing for modular designs. Additionally, the economic considerations of using additive manufacturing for bespoke seating components were not covered in this research.

A limitation of the testing configuration used was that it differed from the standard fixation method. For testing, the multi-point fixing bracket was fixed onto an aluminium block (Figure 5) instead of a wheelchair backrest. This testing configuration was predicted to be stronger, which may affect both the magnitude of force and the point of failure on the bracketry.

Future work

Future research should refine design and manufacturing parameters. This should be informed by measures of the loads users exert on head supports, the effect of long-term cyclic loading and loads experienced in automotive crash testing. Iterative design and testing could include the application of computation tools, such as Finite Element Analysis (FEA). Both Faustini *et al* (2008) and Harper *et al* (2014) used a combination of FEA and mechanical testing to reverse engineer ankle-foot orthotics using Selective Laser Sintering (SLS) [26-27]. However, SLS produces solid infill components, whilst the components produced for this study (which used a CFF method) had an internal honeycomb structure and were therefore partly hollow. A 100% infill could potentially have been achieved with the CFF machine, however it was not practical in terms of time and material costs. This could impact on the effectiveness of FEA to predict the mechanical properties of these parts and may require powerful software, hardware and expertise to complete the analysis. FEA assumes a homogenous manufacturing process for example injection moulding. Although this is a challenge within a resource-constrained clinical environment [17], FEA could be an appropriate method to develop consistent rules that would avoid the need to validate each design [18].

In parallel to establishing design and manufacturing parameters, clinically-important measures, such as comfort, pressure distribution and ability to support the head should also be the focus of future work. This is essential to ensure both wheelchair users and those delivering clinical services can use CAD/additive manufacturing effectively.

Finally, further work should consider the financial implication of implementing CAD and additive manufacturing machines into specialist seating services. The general downward cost trend of additive manufacturing and increasing availability indicates that adoption into routine clinical application is likely, although, as with any design and manufacturing process, it must be implemented with appropriate quality control systems.

Conclusion

This paper presents a step towards a CAD/additive manufacturing workflow that could be applied to providing bespoke seating components, such as head supports, for wheelchair users which are safe and appropriate for clinical use. The results from the mechanical testing performed in this study provide an important step forwards towards evaluating additive manufacturing. However further research is required that addresses the limitations identified and evaluates the performance of additive manufacturing head support when subjected to prolonged exposure to mechanical forces. It is anticipated that the need for bespoke patient devices will increase and therefore this work could

inform workflows for wheelchair services, specialist equipment providers and manufacturers to implement which meet safe design guidelines and rules for compliance with appropriate quality standards. In the longer term, refinement of design workflow and design automation could make CAD/additive manufacturing a cost effective and closer to the point of care method for custom assistive technology device production.

Acknowledgements

The mechanical testing presented in this paper was supported by the College of Engineering, Swansea University. The authors would like to acknowledge the resources and support given by Dr Mark Bowtell, the Medical Physics and Clinical Engineering department at Swansea Bay University Health Board, NHS Wales and the Workforce, Education and Development Services (WEDS), Welsh Government.

Author Disclosure Statement

The author(s) have no potential conflicts of interest with respect to the research, authorship, and/or publication of this article. No financial support was received for the research, authorship, and/or publication of this article.

References

1. NHS support England. NHS support Standard Contract for complex disability equipment: Specialised wheelchair and seating services (All Ages). <http://webarchive.nationalarchives.gov.uk/20160607070644/https://www.england.nhs.uk/wp-content/uploads/2013/06/d01-com-dis-equ-spec-wheelec.pdf> [2013, accessed 01 November 2018].
2. Long D, Posture Management. In: Taktak A, Ganney P, Long D, et al (eds) *Clinical Engineering: A Handbook for Clinical and Biomedical Engineers*. Oxford: Academic Press, 2014; 285-308.
3. Cooper R. *Rehabilitation Engineering applied to mobility and manipulation*. Bristol: Institute of Physics Publishing, 1995; 337-377.
4. Tasker L H, Shapcott N G, Holland P M. The use and validation of a laser scanner for computer aided design and manufacturing of wheelchair seating. *J Medical Engineering Technology*. 2011; 35: 6-7.
5. Long D, Wheelchair Prescription. In: Taktak A, Ganney P, Long D, et al (eds) *Clinical Engineering: A Handbook for Clinical and Biomedical Engineers*. Oxford: Academic Press, 2014; 285-308.
6. Appleyard B, Arva J, Bingham R, et al. Transportation of People in Seated in Wheelchairs: International Best Practise Guidelines. *4th International Interdisciplinary Conferences on Posture and Wheeled Mobility*, 2013.
7. Pope P M. *Severe and Complex Neurological Disability*, Elsevier, 2007.
8. Batavia M. *The Wheelchair Evaluation: A Clinician's Guide*. Sudbury: Jones and Bartlett Publishers, 2010.
9. Ford S, Despeisse M. Additive manufacturing and sustainability: an exploratory study of the advantages and disadvantages. *Journal of Cleaner production* 2013; 137: 1573-1587.
10. Zanetti E M, Aldieri A, Terzini M, et al. Additively manufactured custom load-bearing implantable devices: grounds for caution. *Australasian Medical Journal* 2017; 10: 694-700.
11. Bibb R, Eggbeer D, Evans P, et al. Rapid manufacture of custom-fitting surgical guides. *Rapid Prototyping Journal*. 2009; 15: 246-354.
12. Van der Zel J, Vlaar S, de Ruitter W J, et al. The CICERO system for CAD/C additive manufacturing fabrication of full ceramic crowns. *Journal Prosthetic Dentistry*. 2001; 85: 261-267.
13. Banks J. Adding Value in Additive Manufacturing : Researchers in the United Kingdom and Europe Look to 3D Printing for Customization. *IEEE Pulse*. 2013; 4: 22-26.
14. Herlin C, Koppe M, B´eziat J-L, et al. Rapid prototyping in craniofacial surgery: using a positioning guide after zygomatic osteotomy—a case report. *Journal of CranioMaxillofacial Surgery*. 2011; 39: 376–379.

15. Dawood A, Marti B M, Sauret-Jackson V, et al. 3D printing in dentistry. *British Dental Journal*. 2015; 219: 521–529.
16. Harrysson O L A, Cansizoglu O, Marcellin-Little D J, et al. Direct metal fabrication of titanium implants with tailored materials and mechanical properties using electron beam melting technology. *Materials Science and Engineering*. 2008; 28: 366–373.
17. Chen R K, Jin Y A, Wensman J, et al. Additive manufacturing of custom orthoses and prostheses - a review. *J Additive Manufacturing*. 2016; 12: 77-89.
18. Lunsford C, Grindle G, Salatin B, et al. Innovations with 3-Dimensional Printing in Physical medicine and Rehabilitation: A Review of the Literature. *American Academy of Physical Medicine and Rehabilitation*. 2016; 8: 1201-1212.
19. Pallari J H P, Dalgarno K W, Woodburn J. Mass customization of foot orthoses for rheumatoid arthritis using selective laser sintering. *IEEE Transactions on Biomedical Engineering*. 2010; 57: 1750–1756.
20. Wohlers T. 3D printing and additive manufacturing state of the industry Annual Worldwide Progress Report. Wohlers Report, 2018.
21. Ngoa T D, Kashania A, Imbalzano G, et al. Additive manufacturing (3D printing): A review of materials, methods, applications and challenges. *Composites Part B: Engineering*. 2018; 143: 172-196.
22. Nace S, Tiernan J, Annaidh A N. Manufacturing custom-contoured wheelchair seating: A state-of-the-art review. *Prosthetics and Orthotics International*. 2019; 43: 382-395
23. Jacobs P F. Rapid Prototyping & Manufacturing. Fundamentals of StereoLithography. *Society of Manufacturing Engineers*. 1992, 112-113.
24. BS ISO 16840-3: 2014 Wheelchair Seating. Part 3: Determination of static, impact and repetitive load strengths for postural support devices.
25. Evans A G, Zok F W. The physics and mechanics of fibre-reinforced brittle matrix composites. *Journal of Materials Science*. 1994; 29: 3857-3896.
26. Faustini M C, Neptune R R, Crawford R H, et al. Manufacture of Passive Dynamic Ankle-Foot Orthoses Using Selective Laser Sintering. *IEEE Transactions on Biomedical Engineering*. 2008; 55: 784-790.
27. Harper N G, Esposito E R, Wilken J M, et al. The influence of ankle-foot orthosis stiffness on walking performance in individuals with lower-limb impairments. *Clinical Biomechanics*. 2014; 29: 877-884