



SUB-COMMITTEE ON STABILITY AND  
LOAD LINES AND ON FISHING VESSELS  
SAFETY  
49th session  
Agenda item 17

SLF 49/17  
22 August 2006  
Original: ENGLISH

## REPORT TO THE MARITIME SAFETY COMMITTEE

### Table of contents

Section	Page
1 GENERAL	3
2 DECISIONS OF OTHER IMO BODIES	6
3 DEVELOPMENT OF EXPLANATORY NOTES FOR HARMONIZED SOLAS CHAPTER II-1	7
4 PASSENGER SHIP SAFETY	13
5 REVISION OF THE INTACT STABILITY CODE	19
6 SAFETY OF SMALL FISHING VESSELS	25
7 HARMONIZATION OF DAMAGE STABILITY PROVISIONS IN OTHER IMO INSTRUMENTS	27
8 CONSIDERATION OF IACS UNIFIED INTERPRETATIONS	30
9 REVISION OF RESOLUTION A.266(VIII)	30
10 TONNAGE MEASUREMENT OF OPEN-TOP CONTAINERSHIPS	32
11 REVIEW OF THE SPS CODE	33
12 ANALYSIS OF DAMAGE CARDS: REVISION OF THE IMO DAMAGE CARD	34
13 REVISION OF MSC/CIRC.650	35
14 WORK PROGRAMME AND AGENDA FOR SLF 50	36

For reasons of economy, this document is printed in a limited number. Delegates are kindly asked to bring their copies to meetings and not to request additional copies.

15	ELECTION OF CHAIRMAN AND VICE-CHAIRMAN FOR 2007	37
16	ANY OTHER BUSINESS	38
17	ACTION REQUESTED OF THE COMMITTEE	38

### LIST OF ANNEXES

ANNEX 1	JUSTIFICATION FOR THE PROPOSALS FOR NEW WORK PROGRAMME ITEMS	
ANNEX 2	DRAFT MSC CIRCULAR ON INTERIM EXPLANATORY NOTES TO THE SOLAS CHAPTER II-1 SUBDIVISION AND DAMAGE STABILITY REGULATIONS	
ANNEX 3	MODIFICATIONS TO THE DRAFT AMENDMENTS PREPARED BY MSC 81 FOR MATTERS RELATED TO FLOODING CASUALTIES	
ANNEX 4	DRAFT MSC CIRCULAR ON PERFORMANCE STANDARDS FOR THE SYSTEMS AND SERVICES TO REMAIN OPERATIONAL ON PASSENGER SHIPS FOR SAFE RETURN TO PORT AND ORDERLY EVACUATION AND ABANDONMENT AFTER A CASUALTY	
ANNEX 5	DRAFT MSC CIRCULAR ON EXPLANATORY NOTES TO THE INTERIM GUIDELINES FOR ALTERNATIVE ASSESSMENT OF THE WEATHER CRITERION	
ANNEX 6	DRAFT MSC CIRCULAR ON REVISED GUIDANCE TO THE MASTER FOR AVOIDING DANGEROUS SITUATIONS IN ADVERSE WEATHER AND SEA CONDITIONS	
ANNEX 7	DRAFT MSC CIRCULAR ON GUIDELINES FOR THE APPROVAL OF STABILITY INSTRUMENTS	
ANNEX 8	UPDATED PLAN OF ACTION FOR THE INTACT STABILITY WORK	
ANNEX 9	DRAFT AMENDMENTS TO THE INTERNATIONAL CODE FOR THE SAFE CARRIAGE OF PACKAGED IRRADIATED NUCLEAR FUEL, PLUTONIUM AND HIGH-LEVEL RADIOACTIVE WASTES ON BOARD SHIPS (INF CODE)	
ANNEX 10	DRAFT MSC RESOLUTION ON RECOMMENDATIONS CONCERNING TONNAGE MEASUREMENT OF OPEN-TOP CONTAINERSHIPS	
ANNEX 11	DRAFT REVISED FORM OF DAMAGE CARD	
ANNEX 12	PROPOSED REVISED WORK PROGRAMME OF THE SUB-COMMITTEE AND PROVISIONAL AGENDA FOR SLF 50	

## 1 GENERAL

1.1 The Sub-Committee held its forty-ninth session from 24 to 28 July 2006 under the chairmanship of Mr. R. Gehling (Australia). The Vice-Chairman, Mr. Z. Szozda (Poland) was also present.

1.2 The session was attended by delegations from the following Member Governments:

ALGERIA	MALTA
ARGENTINA	MARSHALL ISLANDS
AUSTRALIA	MEXICO
BAHAMAS	MOROCCO
BRAZIL	NETHERLANDS
CANADA	NEW ZEALAND
CHILE	NIGERIA
CHINA	NORWAY
CROATIA	PANAMA
CUBA	PAPUA NEW GUINEA
CYPRUS	PERU
DEMOCRATIC REPUBLIC OF THE CONGO	PHILIPPINES
DENMARK	POLAND
ECUADOR	PORTUGAL
EGYPT	REPUBLIC OF KOREA
FINLAND	RUSSIAN FEDERATION
FRANCE	SAINT KITTS AND NEVIS
GERMANY	SAUDI ARABIA
GREECE	SINGAPORE
ICELAND	SOUTH AFRICA
INDONESIA	SPAIN
IRAN (ISLAMIC REPUBLIC OF)	SWEDEN
IRELAND	THAILAND
ITALY	TURKEY
JAPAN	TUVALU
KENYA	UKRAINE
LATVIA	UNITED KINGDOM
LIBERIA	UNITED STATES
LITHUANIA	URUGUAY
	VENEZUELA

and the following Associate Member of IMO:

HONG KONG, CHINA

1.3 The session was also attended by representatives from the following United Nations specialized agencies:

INTERNATIONAL LABOUR ORGANIZATION (ILO)  
FOOD AND AGRICULTURE ORGANIZATION OF THE UNITED NATIONS (FAO)

1.4 The session was also attended by an observer from the following intergovernmental organization:

EUROPEAN COMMISSION (EC)

1.5 The session was also attended by observers from the following non-governmental organizations:

INTERNATIONAL CHAMBER OF SHIPPING (ICS)  
INTERNATIONAL UNION OF MARINE INSURANCE (IUMI)  
INTERNATIONAL CONFEDERATION OF FREE TRADE UNIONS (ICFTU)  
INTERNATIONAL ASSOCIATION OF CLASSIFICATION SOCIETIES (IACS)  
OIL COMPANIES INTERNATIONAL MARINE FORUM (OCIMF)  
INTERNATIONAL ASSOCIATION OF INDEPENDENT TANKER OWNERS  
(INTERTANKO)  
INTERNATIONAL LIFEBOAT FEDERATION (ILF)  
INTERNATIONAL COUNCIL OF CRUISE LINES (ICCL)  
WORLD NUCLEAR TRANSPORT INSTITUTE (WNTI)  
THE ROYAL INSTITUTION OF NAVAL ARCHITECTS (RINA)  
INTERNATIONAL TOWING TANK CONFERENCE (ITTC)

### **Opening address**

1.6 In welcoming the participants on behalf of the Secretary-General, Mr. K. Sekimizu, Director, Maritime Safety Division, drew the Sub-Committee's attention to the theme for this year's World Maritime Day, which is "Technical co-operation: IMO's response to the 2005 World Summit", with special emphasis on the maritime needs of Africa. He stressed that the theme was chosen to give the Organization the opportunity to contribute, from its perspective, towards the fulfilment of the Millennium Development Goals (MDGs), adopted by the 2000 Millennium Summit and re-affirmed by last year's World Summit.

With regard to the items on the Sub-Committee's agenda, the Director, recalling that MSC 81 approved a comprehensive set of SOLAS amendments and associated guidelines and recommendations to address passenger ship safety, which, once adopted and implemented, will significantly enhance the safety of passenger ships, observed that the Sub-Committee should consider the draft amendments to SOLAS chapter II-1 for matters related to safe return to port after a casualty and water ingress detection and flood level monitoring systems. He emphasized the significant importance of the amendments as they are in line with the guiding philosophy of using the ship as its own best lifeboat, and was sure that the Sub-Committee's outcome would be such that the Committee could finalize its own work on this issue as scheduled.

Turning to the development of explanatory notes for the harmonized SOLAS chapter II-1, which was adopted at MSC 80 and is expected to enter into force on 1 January 2009, the Director, in appreciating the considerable work undertaken by the SDS Correspondence Group to assist the Sub-Committee to progress the matter, conveyed the Secretary-General's expectation that the Sub-Committee would soon finalize the interim explanatory notes so that the industry would have the guidance they need to apply the revised chapter in a uniform and consistent manner.

On the comprehensive revision of the Intact Stability Code, the Director noted that the Sub-Committee had almost finalized the revision which, as a first step, involved restructuring the Code and, as a next step, the Sub-Committee would embark on the development of

performance-based stability criteria to replace, or be added to, the existing prescriptive provisions. He observed that this trend towards goal- or performance-based standards is in line with the directions laid down in the Organization's Strategic Plan, allowing for technological developments and novel solutions, whilst still meeting the goal of providing the highest practicable standards.

Concerning the work on the safety of small fishing vessels with a view to developing safety standards for fishing vessels below 12 m in length, the Director reiterated that, according to ILO and FAO, fishing industry suffers the highest number of fatalities per year and the large majority of them occur on small fishing vessels, which makes work on the safety of small fishing vessels of particular importance; and, as significant progress had been made by the correspondence group, the Secretary-General was confident that the Sub-Committee would accomplish new safety standards before the target completion date.

The Director referred to other important issues on the agenda, namely the harmonization of damage stability provisions in all IMO instruments; the revision of resolution A.266(VIII); the tonnage measurement of open-top containerships; the review of the SPS Code; and the revision of MSC/Circ.650 and, in that context, noting the considerable progress made intersessionally, thanked the correspondence groups, especially their co-ordinators, and all the participating Governments and organizations.

On additional issues of a more general nature, the Director referred to security at IMO meetings and stressed that complacency about security was not an option, and no compromise could be made on this critical issue, and all delegates should therefore abide by the security rules in place, as outlined in the updated security information provided in Circular letter No.2692.

Referring to the Voluntary IMO Member State Audit Scheme, he outlined three areas on which the Secretary-General would appreciate receiving favourable responses from the Member States, namely that they offer themselves for audit, as requested in resolution A.974(24); that they nominate auditors to enable the selection of audit teams for the conduct of the audits of volunteering Members; and that they nominate qualified auditors to participate in the regional training courses which the Organization was planning to convene to provide uniform training for effective implementation of the Scheme. The Director stated that the Secretary-General looked forward to receiving many more offers, together with the particulars of auditors from whom to choose audit teams.

Concerning the planned refurbishment of the Headquarters Building, the Director reminded delegates that the building would be closed for approximately 12 months between the summers of 2006 and 2007, during which period the Secretariat would move to offices provided by the Host Government and the meetings of the Council, Committees and sub-committees would be held elsewhere in London or abroad. In this context, the Director reiterated the Secretary-General's hope that delegates would be prepared to face, with resolute spirit and good humour, any discomfort and disruption from normal operations experienced during the refurbishment period.

### **Chairman's remarks**

1.7 In responding, the Chairman thanked the Director of the Maritime Safety Division, and stated that the Secretary-General's words of encouragement as well as advice and requests would be given every consideration in the deliberations of the Sub-Committee and its working and drafting groups.

### **Statement by the observer from ICCL**

1.8 The observer from ICCL referred to the incident with the cruise ship **Crown Princess** which experienced a large angle of heel while at sea speed and, without presupposing the outcome of the current investigation into this matter, assured the Sub-Committee that the ship's stability was not in doubt as, when the rudder angle was removed, the ship righted itself. The indications were that this incident was a human element matter. The Sub-Committee was advised that ICCL apologized for this incident which resulted in injury to a number of passengers and crew, and that ICCL members would watch this matter very closely and be ready to undertake any operational or other action as may be indicated necessary by the outcome of the investigation.

### **Adoption of the agenda**

1.9 The Sub-Committee adopted the agenda (SLF 49/1) and agreed, in general, to be guided in its work by the annotations to the provisional agenda contained in document SLF 49/1/1. The agenda, as adopted, with the list of documents considered under each agenda item, is set out in document SLF 49/INF.8.

## **2 DECISIONS OF OTHER IMO BODIES**

### **General**

2.1 The Sub-Committee noted the decisions and comments pertaining to its work made by DSC 10, A 24, FP 50, STW 37, DE 49, COMSAR 10, MEPC 54, BLG 10 and MSC 81, as reported in documents SLF 49/2 and SLF 49/2/1, and took them into account in its deliberations when dealing with relevant agenda items.

### **Application of the Committee's Guidelines**

#### ***Start of working groups' work on Monday mornings***

2.2 The Sub-Committee noted that MSC 81 had reaffirmed its decision that a working group may start work on Monday morning before related items have been considered by plenary but that this is an option and should be decided at the meeting with caution. However, whenever possible, terms of reference for such working groups should be agreed at the previous sessions of the parent committee(s) or sub-committee(s). Another option would be that the draft terms of reference of working and drafting groups issued at the beginning of the session, in accordance with paragraph 3.39 of the Guidelines on the organization and method of work, also identify items on which the groups could start, if decided, working on Monday mornings, without prior consideration of the related agenda items in plenary.

#### ***Work method of a working group with splinter group(s)***

2.3 The Sub-Committee noted that MSC 81 had agreed that there should be no official splinter group(s). However, where the establishment of a splinter group(s) was necessary for the facilitation and efficiency of the work, the working group should have a unanimous agreement on its establishment and the outcome of the work of the group(s) should be considered and agreed by members of the working group and incorporated in the report of the working group.

### ***Processing of documentation***

2.4 The Sub-Committee noted that MSC 81 had requested the Secretariat to make every effort to ensure the timely posting of documents on the IMODOCS website and also requested Member Governments and international organizations to submit documents as early as possible and not just on the deadlines of the submission of documents.

### **Numbering of circulars**

2.5 The Sub-Committee noted that, in order to facilitate the identification and retrieval of information circulated by means of joint MSC/MEPC circulars, since September 2005, the Secretariat had started issuing joint MSC/MEPC circulars with the following symbols:

- .1 organization and methods of work, as MSC-MEPC.1/Circ.;
- .2 general matters, as MSC-MEPC.2/Circ.;
- .3 casualty-related matters, as MSC-MEPC.3/Circ.;
- .4 port State control-related matters, as MSC-MEPC.4/Circ.;
- .5 survey and certification-related matters, as MSC-MEPC.5/Circ.;
- .6 national contact points for safety and pollution prevention and response, as MSC-MEPC.6/Circ.; and
- .7 human element-related matters, as MSC-MEPC.7/Circ.,

and that all circulars would be henceforth identified within a circular series, starting with the allocation of “.1” to its symbol, where the circular would not be issued under any other existing circular series symbol.

## **3 DEVELOPMENT OF EXPLANATORY NOTES FOR HARMONIZED SOLAS CHAPTER II-1**

### **General**

3.1 The Sub-Committee recalled that SLF 48, having agreed to the clarification on interpretations to the various regulations of the harmonized SOLAS chapter II-1 which should be included in the explanatory notes, had agreed to finalize the Interim Explanatory Notes at this session, to be issued as an MSC circular, with the possibility of regular revisions until the entry into force of the revised SOLAS chapter II-1 in 2009.

3.2 The Sub-Committee also recalled that SLF 48 had established the SDS Correspondence Group and instructed the group to further develop the Explanatory Notes for the harmonized SOLAS chapter II-1, based on the report of the SDS Working Group (SLF 48/WP.1); and had further agreed to establish, at this session, a working group on subdivision and damage stability.

3.3 The Sub-Committee had for its consideration the report of the SDS Correspondence Group (SLF 49/3) submitted by Sweden and the United States; and documents submitted by Germany (SLF 49/3/4), Norway (SLF 49/3/2, SLF 49/3/3, SLF 49/3/5 and SLF 49/2/2) and Poland (SLF 49/3/1).

### **Outcome of the correspondence group and related submissions**

3.4 The Sub-Committee considered the report of the correspondence group, containing the draft Explanatory Notes for the harmonized SOLAS chapter II-1 with square brackets to indicate areas where there was no general consensus/agreement on the text and, in particular, the draft Guidelines on damage consequence diagrams; the draft Guidance by which Administrations may determine the impact on survivability of open watertight doors permitted by SOLAS regulation II-1/22.4; and the issue that the revised SOLAS chapter II-1 does not contain a requirement for full survivability ( $s = 1$ ) in case of damages forward of the collision bulkhead, together with documents relating to the outcome of the correspondence group and the Explanatory Notes (SLF 49/3/2, SLF 49/3/3, SLF 49/3/4 and SLF 49/3/5).

3.5 Following extensive debate on the above documents, the Sub-Committee, in particular, with regard to:

- .1 the draft Guidelines on damage consequence diagrams, agreed not to include them in the Interim Explanatory Notes at this stage, recognizing that the operational nature of the Guidelines on damage consequence diagrams does not fit for the design nature of the Explanatory Notes and that the complexity of damage consequence diagrams may not provide masters with clear guidance relating to operational conditions, but that the SLF Sub-Committee may develop such guidance in association with the final Explanatory Notes;
- .2 the draft Guidance by which Administrations may determine the impact on survivability of open watertight doors, agreed not to include the guidance in the Interim Explanatory Notes at this stage but to request the Committee to include it as a new item in the Sub-Committee's work programme, in co-operation with other sub-committees, as appropriate, recognizing its operational nature and taking into account the fact that the issue is beyond the current remit of this agenda item (see also paragraph 3.9); and
- .3 the issue that the revised SOLAS chapter II-1 does not contain a requirement for full survivability ( $s = 1$ ) in case of damages forward of the collision bulkhead, agreed not to include the issue in the Interim Explanatory Notes at this stage, recognizing that it was beyond the current remit of this agenda item,

and agreed to refer the aforementioned documents (see paragraph 3.4), except where they relate to the above issues, to the SDS Working Group for consideration in the context of finalization of the Interim Explanatory Notes.

### **Matters related to the outcome of FP 50 and MSC 81**

3.6 The Sub-Committee, following consideration of the outcome of FP 50 (SLF 49/2) with regard to the definition for "unfavourable conditions of trim and list", as contained in draft SOLAS regulation III/3, and document SLF 49/2/2, commenting on possible adverse effects of the new definition as proposed by FP 50, supported the concern expressed in document



SLF 49/2/2 and agreed to refer both documents to the SDS Working Group for detailed consideration.

3.7 The Sub-Committee also considered the view expressed at MSC 81 (SLF 49/2/1) that definitions of “steps” and “recesses” should be added to regulation 12 of the revised SOLAS chapter II-1 and referred the matter to the SDS Working Group for consideration.

### **Other issues related to the revised SOLAS chapter II-1**

3.8 The Sub-Committee considered document SLF 49/3/1 (Poland), addressing long-term actions related to the work on safety of ships in damaged conditions, including development of alternative methodologies, and, having recognized that the above proposal was beyond the remit of this agenda item, invited the delegation of Poland to submit an appropriate proposal for a new work programme item to the Committee in accordance with the Guidelines on the organization and method of work.

### **Guidance on the impact of open watertight doors**

3.9 Further to the decision in paragraph 3.5.2 with regard to the Guidance used for the determination of the impact of open watertight doors on survivability under regulation II-1/22.4, the Sub-Committee, noting, as mentioned by some delegations, the occurrence of casualties associated with the lack of guidance on this issue, agreed to develop guidance as an urgent matter (see also paragraph 3.11).

3.10 In this context, the delegation of Greece stated that they strongly believed that, as a matter of principle, all watertight doors must be kept closed after the departure and during the voyage and that such doors should only be opened momentarily, when it is necessary for the crew to move from one compartment to the adjacent one. As leaving these doors open contradicts the assumptions made when determining the subdivision of the ship taking into account these watertight compartments, it affects the calculation of the stability of the ship after damage. They further pointed out that Greece has experienced casualties which resulted in the loss of lives and its investigations and calculations showed that the rapid sinking of the ships involved was the result of rapid flooding of compartments adjacent to the damaged area through open watertight doors.

### **Justification for a proposal for a new work programme item**

3.11 In view of the above decisions, the Sub-Committee invited interested delegations, in consultation with the Secretariat, to draft a justification for a new work programme item concerning the impact of open watertight doors on survivability under regulation 22.4 of the revised SOLAS chapter II-1 (see paragraphs 3.5.2 and 3.9), for consideration by MSC 82. Having considered document SLF 49/WP.5, the Sub-Committee agreed to the justification for a proposal for a new work programme item, set out in annex 1, and invited the Committee, taking into account the aforementioned justification, to include a new item on “Guidance on the impact of open watertight doors on survivability under regulation 22.4 of the revised SOLAS chapter II-1” in the Sub-Committee’s work programme. The Committee was also requested, as proposed in paragraph 8.2 of the justification, to consider including, in the DE Sub-Committee’s work programme, a new item on the development of guidance to ensure consistent policy for determining the need for watertight doors to remain open during navigation.

### **Establishment of the working group**

3.12 Following the above discussions, the Sub-Committee established the Working Group on Subdivision and Damage Stability, and instructed it, taking into account relevant comments made and decisions taken in plenary, to:

- .1 finalize the draft Interim Explanatory Notes for the revised SOLAS chapter II-1 (resolution MSC.194(80)), based on the report of the SDS Correspondence Group (SLF 49/3), in a format that reflects the regulations of the revised chapter, having considered the inclusion therein of:
  - .1 additional information that includes historical background on damage statistics, survivability criteria, etc.; and
  - .2 the definition of “steps” and “recesses”;
- .2 consider, as requested by FP 50, the draft SOLAS regulation III/3 and provide comments thereon, for consideration by MSC 82; and
- .3 consider whether there is a need for the SDS Correspondence Group and, if so, prepare draft terms of reference for the group, for consideration by plenary.

### **Report of the working group**

3.13 Having received the report of the working group (SLF 49/WP.1), the Sub-Committee approved it in general and took action as outlined in the following paragraphs.

### **Interim Explanatory Notes for harmonized SOLAS chapter II-1**

#### ***Finalization of the draft Interim Explanatory Notes***

3.14 The Sub-Committee noted that the group, taking into account the submissions and discussions in plenary, had considered in detail the draft Interim Explanatory Notes included in the SDS Correspondence Group report (SLF 49/3, annex 1) and that all parts that were left within square brackets and thus had not been fully agreed upon within the correspondence group or previous working group meetings were scrutinized in detail. Considering that these Interim Explanatory Notes needed to be updated when more experience from the new harmonized SOLAS chapter II-1 had been obtained, the Sub-Committee also noted that the general principle applied was to delete all parts that were not supported by a clear majority, which resulted in a document that does not cover all aspects of the regulations, but still was judged to be of essential value for the industry when it starts to use the new regulations for new design purposes. Consequently, the Sub-Committee agreed to the draft MSC circular on Interim Explanatory Notes to the SOLAS chapter II-1 subdivision and damage stability regulations, set out in annex 2, for submission to MSC 82, for approval.

3.15 The Sub-Committee noted the outcome of the working group’s discussion on the following issues which would need further development in the Explanatory Notes, or other action, as appropriate:

*Regulations 5-1 and 7-2*

- .1 Extensive discussion on how to calculate the attained index A and present GM or KG limit curves for different trims in the most efficient way resulted in general support for a new proposal that additional trims could be calculated when necessary for one or several of the draughts taking the partial attained index at a specific draught as the minimum attained index from the different trims calculated with constant GM. This would result in a single limit curve that would assure that the ship in all service conditions fulfills the damage stability requirements. However, the group also noticed that this approach would not be completely in line with the text in regulation 5-1.4 and the new approach was, therefore, not included in the Interim Explanatory Notes at this stage.

*Regulation 7-2.5.2.2*

- .2 Detailed examples of what should be considered as a horizontal evacuation route in the context of the immersion criteria could not be finalized at this stage.

*Regulation 7-2.5.3.3*

- .3 Guidance on the interpretation of this regulation was considered essential but could not be developed at this stage.

*Regulation 9.4*

- .4 Guidance regarding “dry tanks of moderate size” should be included in the Explanatory Notes, since this issue could have a significant impact on survivability in case of grounding.

*Regulation 17*

- .5 MSC/Circ.541 needs to be updated. Interpretations of paragraph 3 need to be further developed.

*Regulation 35-1, paragraphs 3.3 and 3.4*

- .6 It was noted that the terms “same damage” and “all flooding conditions” do not make sense any longer in connection with the probabilistic damage stability regulations and the issue should be further considered.

***Historical background on damage statistics, survivability criteria, etc.***

3.16 The Sub-Committee noted that an introduction part, containing historical background on damage statistics, survivability criteria, etc., had been included in the Interim Explanatory Notes.

***Piping penetrating watertight bulkheads***

3.17 The Sub-Committee noted that the group had considered document SLF 49/3/2 (Norway), containing a list of issues (paragraph 8 of the document) needing interpretation and possible inclusion in the Explanatory Notes in connection with piping penetrating watertight bulkheads and had agreed as follows:

- .1 items 8.1 to 8.5, concerning multiple damage scenarios, and item 8.7, concerning valves for pipes carrying flammable liquids, were considered to be outside the scope of the Interim Explanatory Notes;
- .2 item 8.6, concerning limited progressive flooding in a closed system, should be further considered in order to determine whether more guidance on the matter should be included, but not be included in the Interim Explanatory Notes; and
- .3 items 8.8, concerning shut-off valves, and 8.9, concerning disregarding of small pipes, should be considered for inclusion in the Explanatory Notes, regulation 7.

3.18 With regard to item 8.10, concerning the susceptibility of plastic pipes to damage due to structure movements, the Sub-Committee agreed with the group's recommendation that this could be covered by an IACS interpretation and invited IACS to consider developing such interpretation.

#### ***Definition of “steps” and “recesses”***

3.19 Regarding the issue of whether definitions of “steps” and “recesses” should be added to new SOLAS regulation II-1/12, the Sub-Committee, concurring with the relevant view of the group, agreed that no definitions of “steps” and “recesses” were necessary and noted in this regard the unified interpretation as given in MSC/Circ.1211.

#### ***Lightweight check***

3.20 The Sub-Committee noted that the group had considered document SLF 49/3/4 (Germany), proposing the inclusion, in the Explanatory Notes, of an interpretation based on the recently developed MSC/Circ.1158 on Unified interpretation of SOLAS chapter II-1 (Regulation II-1/22 – Stability information for passenger ships and cargo ships) and had included a reference to MSC/Circ.1158. The Sub-Committee also noted that there was general support in the group for the German proposal to amend the circular set out in the annex to document SLF 49/3/4 and agreed to consider the issue further at SLF 50.

#### **Unfavourable conditions of trim and list (draft amendment to SOLAS regulation III/3)**

3.21 The Sub-Committee noted that the group had considered the definition of *unfavourable conditions of trim and list*, as prepared by FP 50 for inclusion in SOLAS regulation III/3, noting that FP 50, in view of its limited experience with the new probabilistic damage stability requirements in SOLAS chapter II-1, had invited SLF 49 to consider the aforementioned draft definition and forward any comments to MSC 82 so that they could be taken into account when the SOLAS amendments are prepared for adoption. In this connection, the group had also considered document SLF 49/2/2 (Norway), commenting on the draft definition.

3.22 The Sub-Committee agreed with the conclusion of the group that the text of the definition as it stands is not appropriate in the context of performance standards related to probabilistic damage stability and that it should be reconsidered, also recognizing that a single definition used in different parts of SOLAS chapter III is not sufficient. However, the Sub-Committee felt that proposing a new definition was outside its remit and, therefore, invited Member Governments to submit, to MSC 82, concrete text proposals for relevant modifications to the definition.

### **Establishment of the correspondence group**

3.23 The Sub-Committee agreed to re-establish the SDS Correspondence Group, under the co-ordination of Sweden and the United States\*, with the following terms of reference (see also paragraph 4.28):

- .1 to develop additions and improvements to the Interim Explanatory Notes to the SOLAS chapter II-1 subdivision and damage stability regulations and identify any regulations that need future improvement;
- .2 to develop a draft MSC circular on Guidelines for damage control plans and information to the master, on the basis of the draft contained in document SLF 49/3, taking into account, in particular, the development of guidance for the master in the context of new draft regulation II-1/8-1; and
- .3 to submit a report to SLF 50.

### **Extension of the target completion date of the item**

3.24 Consequently, the Sub-Committee agreed to invite the Committee to extend the target completion date of the item to 2007.

## **4 PASSENGER SHIP SAFETY**

### **General**

4.1 The Sub-Committee recalled that SLF 48:

- .1 having considered tasks assigned by MSC 80 regarding casualty threshold for return to port, casualty scenario for the time for orderly evacuation and abandonment, measures to limit the speed of flooding, raking damage issues and alternative design and arrangements, took the appropriate decisions;
- .2 on the specific request of FP 49 to review the draft amendments to SOLAS chapter II-2 on functional requirement for safe areas, had agreed that the amendments should also address flooding issues; and
- .3 on the request of DE 48 to review the draft performance standards for essential systems and equipment on passenger ships for safe return to port after a casualty and the draft performance standards for essential systems and equipment on passenger ships for the time for orderly evacuation and abandonment, had agreed

---

\* **Co-ordinators:**

Mr. Goran Liljestrom  
Swedish Maritime Administration  
601 78 Norrköping  
Sweden  
Tel.: +46 11 191000  
Fax: +46 11 239934  
E-mail: [goran.liljestrom@sjofartsverket.se](mailto:goran.liljestrom@sjofartsverket.se)

Mr. James Person  
Commandant (G-PSE-2)  
United States Coast Guard  
2100 Second St., S.W.  
Washington, D.C. 20593  
Tel.: +1 202 372 1369  
Fax: +1 202 372 1925  
E-mail: [jperson@comdt.uscg.mil](mailto:jperson@comdt.uscg.mil)

that flooding detection systems and bilge systems should be included in the draft standards, respectively.

4.2 The Sub-Committee also recalled that SLF 48 had agreed to add the following tasks to the SDS Correspondence Group's terms of reference:

- .1 to develop criteria for safe return to port, either under own power or under tow, using, as a basis, the casualty threshold contained in the new SOLAS regulation II-1/8; and
- .2 to prepare mandatory requirements for water ingress detection and flooding level monitoring systems,

and had also agreed to forward this matter to the SDS Working Group at this session for further consideration.

4.3 The Sub-Committee had for its consideration the report of the SDS Correspondence Group (SLF 49/4/1) submitted by Sweden and the United States; and documents submitted by Germany (SLF 49/4/3 and SLF 49/INF.5), Poland (SLF 49/4/4), the United Kingdom (SLF 49/4/7), the United States (SLF 49/INF.2), ICCL (SLF 49/4/5), ITTC (SLF 49/4/2) and the Secretariat (SLF 49/4 and SLF 49/4/6).

#### **Outcome of other bodies**

4.4 In considering documents SLF 49/4 and SLF 49/4/6 (Secretariat), containing information on the outcomes of FP 50, STW 37, DE 49, COMSAR 10 and MSC 81, the Sub-Committee noted that MSC 81 had:

- .1 approved the draft amendments to SOLAS chapters II-1, II-2 and III for circulation with a view to consideration and subsequent adoption at MSC 82, taking into account that the holistic nature of the package requires all the amendments to be considered at the same time;
- .2 instructed SLF 49, with a view to finalization, to:
  - .1 consider the text in square brackets for draft regulations II-1/8-1 and II-1/22-1;
  - .2 consider the text in square brackets in draft regulations II-2/21 and II-2/23 for matters related to flooding casualties; and
  - .3 prepare relevant amendments to draft regulation II-2/22, taking into account that paragraph 3.2 related thereto only applies to fire casualties and bearing in mind that the aforementioned regulation has only been drafted from a fire safety perspective,

and to forward any proposed recommendations to MSC 82 for consideration and action, as appropriate, when adopting the proposed amendments to SOLAS chapters II-1, II-2 and III. The above draft amendments are set out in annex 1 to document SLF 49/4/6;

- .3 approved, in principle, the draft MSC circular on Performance standards for the systems and services to remain operational for safe return to port and orderly evacuation and abandonment, as set out in annex 2 to document SLF 49/4/6, and instructed SLF 49 to finalize the aforementioned standards for the matters under their purview, and to submit them to MSC 82 for formal approval, together with the adoption of the relevant draft amendments to SOLAS chapter II-2;
- .4 having noted that the COMSAR, DE, FP and NAV Sub-Committees had completed the work assigned to them, consolidated and redrafted the remaining tasks in the work plan, as set out in annex 3 to document SLF 49/4/6, for consideration and action, as appropriate, by the SLF and STW Sub-Committees; and
- .5 having finalized its tasks on this issue, agreed to proposed additions to the Sub-Committee's work programme, as set out in the annex to document SLF 49/2/1, taking into account that consequential work needed to be carried out accordingly.

#### **Report of the correspondence group**

4.5 Having considered the report of the Correspondence Group on Subdivision and Damage Stability for matters related to passenger ship safety (SLF 49/4/1) and the relevant submissions by Germany (SLF 49/4/3), Poland (SLF 49/4/4), ICCL (SLF 49/4/5) and the United Kingdom (SLF 49/4/7), the Sub-Committee, having noted that:

- .1 with regard to criteria for safe return to port under own power, some delegations expressed the view that the stability criteria represented by  $s_i = 1$ , as agreed by the majority of the correspondence group, would not be sufficient;
- .2 a number of delegations supported the proposal by ICCL (SLF 49/4/5), proposing that passenger ships be designed to return to port under their own power with any one main compartment flooded, while providing all the services required for safe areas as envisioned in draft SOLAS regulation II-2/21; and
- .3 that there was mixed support regarding the appropriate "applicability" options prepared by the correspondence group for the safe return to port provisions,

agreed to refer the above matters to the SDS Working Group for further consideration with a view towards finalization.

4.6 In considering the draft SOLAS regulations II-1/8-1 and II-1/22-1, the Sub-Committee noted that the draft amendments related and made reference to regulations contained in the revised SOLAS chapter II-1 which is expected to enter into force on 1 January 2009. Recognizing that the aforementioned draft amendments cannot be adopted or become effective until the entry-into-force date, the Sub-Committee agreed that possibilities should be considered for the draft amendments to be adopted simultaneously with the draft amendments to SOLAS chapters II-2 and III referred to in paragraph 4.4.1.

## **Research related to passenger ship survivability**

4.7 The Sub-Committee noted with appreciation the ongoing research being conducted by Germany (SLF 49/INF.5) and the United States (SLF 49/INF.2) on matters related to the survivability of passenger ships in the damaged condition.

## **Instructions to the SDS Working Group**

4.8 The Sub-Committee agreed to instruct the SDS Working Group, established under agenda item 3, taking into account comments made and decisions taken in plenary, to:

- .1 finalize matters related to draft SOLAS regulations II-1/8-1 and II-1/22-1 prepared by MSC 81 (SLF 49/4/6), taking into account documents SLF 49/4, SLF 49/4/1, SLF 49/4/3, SLF 49/4/4, SLF 49/4/5 and SLF 49/4/7, and also advise the Sub-Committee on possible options for the draft amendments to be adopted or made effective at MSC 82;
- .2 consider the relevant provisions of draft regulations II-2/21, II-2/22 and II-2/23 for matters related to flooding casualties and make recommendations, as deemed appropriate, taking into account document SLF 49/4/6; and
- .3 finalize the draft MSC circular on Performance standards for the systems and services to remain operational for safe return to port and orderly evacuation and abandonment, as set out in annex 2 to document SLF 49/4/6, for the matters under the Sub-Committee's purview.

## **Report of the working group**

4.9 Having considered the part of the report of the working group (SLF 49/WP.1/Add.1) relating to the item, the Sub-Committee approved it in general and took action as outlined in the following paragraphs.

## **Review of draft amendments to SOLAS chapter II-1 flooding casualties<sup>\*</sup>**

### ***Safe return to port (draft regulation 8-1)***

4.10 The Sub-Committee noted that the group had first considered matters related to the safe return to port capability for passenger ships in the damaged condition, taking into account the draft amendments prepared by MSC 81 set out in annex 1 to document SLF 49/4/6.

4.11 In considering whether the survivability criteria for the *return to port under tow* case should be viewed separately from the *return to port under own power* case, the Sub-Committee noted that the group, having noted the views of the correspondence group that the criteria should be separated since a ship with propulsion capability can manoeuvre to mitigate dangerous headings if the weather deteriorates, had agreed that a higher survivability criteria could be adequate for ships when the propulsion is lost and, therefore, the survivability criteria should be different for each case.

---

\* Refer to paragraphs 2, 3 and 30 of annex 1 to document MSC 82/3.



4.12 In regard to matters related to the survivability criteria proposed by the correspondence group for return to port under own power, the Sub-Committee noted that the group had agreed to an  $s_i = 1$  survivability criterion for safe return to port under own power.

4.13 Referring to the above decision, the delegations of Germany and the United Kingdom expressed their reservations for using  $s_i = 1$  for the damage cases where the propulsion is not lost. They pointed out that the suggested criterion of  $s_i = 1$  for return to port (and tow to port) are derived from survivability criterion for damaged passenger vessels and that these criteria are based on the righting lever curve of the immobile vessel in moderate sea states and assess the reserve of stability, inclining moments and safety of the passengers due to high heeling angles. Additional reserves of stability to account for the additional accelerations, ship motions and induced waves of the vessel in transit are not considered as the criteria were not developed for the safe voyage back to port including passage through prevailing sea states over large distances.

4.14 The observer of the ICFTU expressed concerns that the Sub-Committee had failed to increase the stability criteria for ships returning to port under power and that the footnote for masters to regulation 8-1 was insufficient. These concerns were supported by several delegations.

4.15 The Sub-Committee noted that the group had considered the four options for the “safe return to port under tow” case prepared by the correspondence group and agreed to an  $s_i = 1$  survivability criterion calculated with a wind heeling moment accounting for an increased wind pressure of  $240 \text{ N/m}^2$ . The Sub-Committee also noted that the group, after having noted that this may be too onerous for certain conditions, had decided to include the possibility for Administrations to consider lower pressures for ships operating under restricted conditions.

4.16 In noting that there is a general lack of knowledge of the behaviour of damaged ships under way, the Sub-Committee encouraged ITTC to collect information on this issue for further consideration by the Sub-Committee.

4.17 In regard to matters related to the extent of damage, the Sub-Committee agreed that this should be a general requirement while increased survivability criteria for returning to port either under own propulsion or under tow should be applied by using the minor damage criteria set out in regulation 8.3 as a basis.

4.18 With respect to the footnote to the draft regulation 8-1, the delegation of Bahamas stated that there was no support for masters to judge as to whether these criteria, set out in the draft regulation 8-1, provide adequate reserves of stability in the prevailing conditions and, therefore, there was a need to develop relevant guidelines for the master, considering the importance of the human element.

#### ***Water ingress detection and flood level monitoring systems (draft regulation 22-1)***

4.19 In considering draft regulation 22-1, the Sub-Committee agreed that the new provision should only refer to flooding detection systems, the term of which encompasses a full range of systems, and agreed that detailed specifications for such systems should be contained in separate guidelines.

#### ***Application of the new regulations II-1/8-1 and II-1/22-1***

4.20 The Sub-Committee noted that the group had considered the four options discussed by the correspondence group for the “applicability” of the new safe return to port requirements (draft

regulation 8-1), in particular whether they should apply to all passenger ships; passenger ships carrying 36 or more persons; passenger ships carrying 400 or more persons; or to passenger ships carrying 1,500 or more persons, and had noted that the following two options had the most support:

- .1 to apply the new requirements to passenger ships carrying 400 or more persons, taking into account that even a small passenger ship can be difficult to assist in an emergency if located in an area remote from SAR facilities; or
- .2 to apply the new requirements passenger ships carrying 1,500 or more persons based on the principle that the increased survivability initiative was targeted at large cruise ships, taking into account that smaller ships may have difficulty applying the new provision.

4.21 Having been unable to reach a firm majority for either of the above options, the Sub-Committee agreed that the above applicability provisions should be left in square brackets for consideration by MSC 82, taking into account the holistic nature of the passenger ship safety initiative.

4.22 In considering the new provisions for flooding detection systems (draft regulation 22-1), the Sub-Committee agreed to apply this new requirement to passenger ships carrying 36 or more persons since these systems would be beneficial to both small and large passenger ships and not be difficult to install in either case. In doing so, the Sub-Committee noted that the guidelines to be developed would provide detailed specifications for ships of different sizes.

#### ***Draft amendments for SOLAS chapter II-1 for flooding casualties***

4.23 Having considered the above matters, the Sub-Committee agreed to the modifications to the draft amendments to SOLAS chapter II-1 prepared by MSC 81 for matters related to flooding casualties, i.e., the revised draft SOLAS regulations II-1/8-1 and II-1/22-1, set out in annex 3, for submission to MSC 82 for consideration and action as appropriate.

#### ***Adoption of the draft amendments related to the passenger ship safety initiative***

4.24 With regard to the possible options for bringing the aforementioned revised draft SOLAS regulations II-1/8-1 and II-1/22-1 into effect, the Sub-Committee, noting that the revised SOLAS chapter II-1 parts A, B and B-1 will not be accepted until 1 July 2008, was of the opinion that the revised SOLAS chapter II-1 should be readopted with the inclusion of the aforementioned revised draft regulations II-1/8-1 and II-1/22-1, bearing in mind that this will not affect the entry into force date of the revised SOLAS chapter II-1 nor would it delay the adoption of the other amendments prepared as part of the passenger ship safety initiative. In this context, the Sub-Committee was also of the view that the draft amendments to SOLAS chapters II-1, II-2 and III related to the passenger ship safety initiative should be adopted as a package, with the entry-into-force date of the revised SOLAS chapter II-1, i.e., 1 January 2009. The Committee was invited to consider the above views when adopting the set of amendments related to this initiative and take actions as appropriate.

#### **Review of draft amendments to SOLAS chapter II-2 for flooding casualties**

4.25 The Sub-Committee agreed to the modifications to the draft amendments to SOLAS chapter II-2, prepared by MSC 81, for matters related to flooding casualties, set out in annex 3,

for submission to MSC 82 for consideration, when adopting the draft amendments to SOLAS chapter II-2 related to the passenger ship safety initiative, and action as appropriate.

4.26 The delegation of Germany expressed its view that the concept of “time for orderly evacuation and abandonment”, introduced with SOLAS regulation II-2/22 for fire casualties, should also be applied to flooding casualties in the interest of a holistic safety approach. It informed the Sub-Committee that research to this end is making progress, as reflected in document SLF 49/INF.5, and expressed the view that this matter should remain open for future amendments as soon as appropriate provisions for flooding casualties can be developed (see also paragraph 14.1.3).

### **Review of draft performance standards for essential systems**

4.27 The Sub-Committee agreed to the draft MSC circular on Performance standards for the systems and services to remain operational on passenger ships for safe return to port and orderly evacuation and abandonment after a casualty, set out in annex 4, for submission to MSC 82 for approval simultaneously with the adoption of the draft amendments to SOLAS chapter II-2 related to the passenger ship safety initiative, referred to in paragraph 4.25.

### **Terms of reference for the SDS Correspondence Group**

4.28 The Sub-Committee agreed to add, to the SDS Correspondence Group, an additional item to its terms of reference, namely, to prepare guidelines for flooding detection systems (see also paragraph 3.23).

4.29 In this regard, the Sub-Committee supported the views of the delegation of the Bahamas that the terms of reference of the SDS Correspondence Group, concerning the development of draft MSC circular on Guidelines for damage control plans and information to the master should also apply to passenger ships (see paragraph 3.23.2).

### **Completion of the item**

4.30 Having considered the above issues, the Sub-Committee agreed to invite the Committee to delete this item from its work programme since the work on this matter has been concluded.

## **5 REVISION OF THE INTACT STABILITY CODE**

### **General**

5.1 The Sub-Committee recalled that SLF 48, having considered the report of the working group (SLF 48/WP.2), in particular agreed:

- .1 to the draft MSC circular on Interim Guidelines for alternative assessment of the weather criterion, for submission to MSC 81 for approval; and
- .2 that relevant chapters of the draft revised Code should be referred to the DE and STW Sub-Committees for their review and comments,

and, in the context of subparagraph .1, the Sub-Committee noted that MSC 81 had approved the Interim Guidelines for alternative assessment of the weather criterion, for dissemination by means of MSC.1/Circ.1200.

5.2 The Sub-Committee also recalled that SLF 48, having agreed to establish the Correspondence Group on Intact Stability, under the co-ordination of Germany, to prepare a complete draft revised Intact Stability (IS) Code, instructed it to submit a report to SLF 49; and had further agreed to re-establish, at this session, a Working Group on Intact Stability.

5.3 The Sub-Committee had for its consideration the second part of the report of the IS Working Group at SLF 48 (SLF 49/5/1) submitted by the Chairman of the working group and the report of the IS Correspondence Group (SLF 49/5 and SLF 49/5/4) submitted by Germany; and documents submitted by Australia (SLF 49/INF.4 and SLF 49/INF.4/Add.1), Australia and Spain (SLF 49/5/11), China (SLF 49/5/12), Germany (SLF 49/5/4 and SLF 49/INF.3), Japan (SLF 49/5/5, SLF 49/5/6, SLF 49/5/7 and SLF 49/INF.6), the Netherlands (SLF 49/5/8 and SLF 49/INF.7), Norway (SLF 49/5/13 and SLF 49/5/14), Poland (SLF 49/5/10), Spain (SLF 49/5/9) and the Secretariat (SLF 49/5/3).

### **Revision of the Intact Stability Code**

5.4 The Sub-Committee, having considered the report of the working group and the correspondence group (SLF 49/5/1, SLF 49/5 and part of SLF 49/5/4) as well as the outcomes of STW 37 and DE 49 (SLF 49/5/3), agreed to refer those documents to the working group for further examination.

5.5 With regard to the status of guidelines for the approval of stability instruments (annex 2 to SLF 49/5/4) and the approval of hardware, the Sub-Committee noted that the guidelines should be a supplementary information to the IS Code and reaffirmed its decision at SLF 48 that the hardware should not be approved.

5.6 In the course of the discussion, a question was raised on the operational nature of requirements for fishing vessels (IS Code, part B, section 2.1), and the Sub-Committee agreed to also refer the matter to the Working Group on Safety of Small Fishing Vessels established under agenda item 6 (see paragraph 6.11).

### **Revision of MSC/Circ.707 (Guidance for the master for avoiding dangerous situations in adverse weather and sea conditions)**

5.7 Having considered the part of the correspondence group's report (SLF 49/5/4) related to the revision of MSC/Circ.707 and proposals thereon by Australia and Spain (SLF 49/5/11), identifying areas for improvement on the outcome of the correspondence group and proposing a revised format for clearer information for masters, the Sub-Committee supported the aforementioned proposal with a view towards clarity.

5.8 As to whether the Guidance should be ship-independent or not, the Sub-Committee agreed that the Guidance should be ship-independent. The Sub-Committee also noted documents SLF 49/INF.4 and SLF 49/INF.4/Add.1, providing information in respect of further Australian research into parametric rolling in head seas, and agreed to refer them to the working group for further consideration.

## **Review of the long-term tasks contained in the Updated plan of action**

### ***Development of performance-based criteria***

5.9 The Sub-Committee, having considered the part of the correspondence group's report (SLF 49/5/4) regarding the development of performance-based criteria for dynamic stability phenomena and related documents (SLF 49/5/2, SLF 49/5/4, SLF 49/5/5, SLF 49/5/6, SLF 49/5/7, SLF 49/5/8, SLF 49/5/10, SLF 49/INF.3, SLF 49/INF.6 and SLF 49/INF.7), noted various views, including how to proceed with this long-term task.

### ***Additional ship types***

5.10 The Sub-Committee also noted documents SLF 49/5/9 and SLF 49/5/12, proposing the stability criteria for additional ship types.

### ***Implementation of mandatory part A of the IS Code***

5.11 In considering documents SLF 49/5/13 and SLF 49/5/14 regarding how to implement a mandatory part A of the IS Code, the Sub-Committee, having recalled that further amendments to SOLAS chapter II-1 to make parts of the Code mandatory cannot be adopted before the last amendments' entry-into-force date of 1 January 2009, agreed that the working group should further consider this matter and advise the Sub-Committee accordingly.

### ***General***

5.12 After extensive discussions on issues, concerning long-term tasks, as contained in the Updated plan of action for intact stability work (SLF 48/WP.2, annex 3), the Sub-Committee agreed to refer these matters, including the review of the plan of action on long-term tasks, to the working group for further consideration.

### **Establishment of the working group**

5.13 The Sub-Committee established the Working Group on Intact Stability, and instructed it, taking into account comments made and decisions taken in plenary, to:

- .1 prepare the draft revised IS Code on the basis of the text contained in the report of the correspondence group (SLF 49/5), taking into account part 2 of the report of the SLF 48 working group (SLF 49/5/1) and the outcome of STW 37 and DE 49 (SLF 49/5/3), and documents commenting thereon;
- .2 consider the revision of MSC/Circ.707 on Guidance to the master for avoiding dangerous situations in following and quartering seas, on the basis of the draft contained in the report of the correspondence group (SLF 49/5/4, annex 1), taking into account document SLF 49/5/11;
- .3 continue to work on the items contained in the updated plan of action for intact stability work, as set out in annex 3 to document SLF 48/WP.2, as well as on the development of guidelines for the approval of stability instrument software, taking into account documents SLF 49/5/2, SLF 49/5/4, SLF 49/5/5, SLF 49/5/6, SLF 49/5/7, SLF 49/5/8, SLF 49/5/9, SLF 49/5/10, SLF 49/5/12, SLF 49/5/13, SLF 49/5/14, SLF 49/INF.3, SLF 49/INF.6 and SLF 49/INF.7;

- .4 review the plan of action on this item, based on the updated plan of action (SLF 48/WP.2, annex 3), and progress made during the session;
- .5 make recommendations and prepare documentation for any amendments to the work programme, if necessary, such as renaming the item following completion of the revised IS Code and justification for the proposed new work programme item on performance-based intact stability criteria; and
- .6 consider whether it is necessary to re-establish the correspondence group on intact stability and, if so, prepare terms of reference of the group.

### **Report of the working group**

5.14 Having received the report of the working group (SLF 49/WP.2 and Add.1), the Sub-Committee approved it in general and took action as indicated in the following paragraphs.

### **Draft revised IS Code**

5.15 The Sub-Committee agreed, in principle, to the modifications, set out in annex 1 to document SLF 49/WP.2, to the text of the draft revised IS Code contained in document SLF 49/5 (see also paragraph 5.25). The basis for the aforementioned modifications are listed below:

- .1 clarification of the criteria of certain ship types (offshore supply vessels and special purpose ships) that may be applied in lieu of the general mandatory criteria of part A, chapter 2.2;
- .2 addition, to the beginning of the Explanatory Notes, chapter 3 of part C of the draft revised IS Code, of paragraphs 5 and 6 contained in document SLF 49/5/1 (part 2 of the report of the working group at SLF 48);
- .3 Explanatory Notes, part C of the draft revised IS Code, were agreed to be removed from the IS Code. Consequently, the Sub-Committee agreed to further develop the draft MSC circular on Explanatory Notes to the Intact Stability Code at SLF 50 in conjunction with finalization of the draft revised IS Code;
- .4 taking into consideration the outcome of STW 37 and DE 49 (SLF 49/5/3), the Sub-Committee agreed to modify chapter 4 of part B of the draft revised IS Code; and
- .5 the Sub-Committee took note of the opinion expressed in paragraph 2 of document SLF 49/5/3 (Secretariat) on guidance meant for the fishing industry; and concurred with the view accepted by STW 37 on this matter.

5.16 The Sub-Committee, taking into account that the Interim guidelines for the alternative assessment of the weather criterion (annex 1 to the draft revised IS Code) had already been issued as document MSC.1/Circ.1200, agreed to the draft MSC circular on Explanatory Notes to the Interim Guidelines for alternative assessment of the weather criterion, set out in annex 5, for submission to MSC 82 for approval.

### **Amendments to mandatory instruments to make part A of the IS Code mandatory**

5.17 The Sub-Committee noted the group's discussion with regard to mandatory instruments which should be amended to make part A of the Code mandatory as outlined in paragraphs 7 to 9 of SLF 49/WP.2 and endorsed the group's view on the need to amend both the 1974 SOLAS Convention and the 1988 LL Protocol in order to gain the widest application of the mandatory criteria of the IS Code. Recognizing the complexity of making mandatory of the IS Code under the two instruments, the Sub-Committee agreed to instruct the IS Correspondence Group to develop draft amendments to the both instruments (see also paragraph 5.24.1) for consideration at SLF 50, with a view to taking appropriate decision.

### **Inclusion of an equivalence section in part A of the draft revised IS Code**

5.18 The Sub-Committee, having considered the group's view on the inclusion of an equivalency section in part A of the draft revised IS Code, similar to that contained in section 1.4 of the IGC and IBC Codes and section 1.11 of the 2000 HSC Code, in order to facilitate the approval of new designs or novel features which might not be adequately covered by alternative criteria already contained in part B, agreed to instruct the IS Correspondence Group to examine the matter further with a view to considering the pros and cons for the inclusion of an equivalency section in part A and to make recommendations to SLF 50 as appropriate (see also paragraph 5.24.2).

5.19 The Sub-Committee, having noted the concern that some ships, especially those with a wide beam and small depth, have difficulty in complying with the criterion of the minimum angle of 25° of the maximum GZ value (draft revised IS Code, part A, paragraph 2.2.3) as outlined in paragraph 11 of SLF 49/WP.2, agreed that this matter should be considered by the correspondence group with a view to recommending an appropriate solution (see also paragraph 5.24.3).

### **Revision of MSC/Circ.707**

5.20 In considering the revision of the Guidance to the master for avoiding dangerous situations in following and quartering seas (MSC/Circ.707), the Sub-Committee, having endorsed the group's view that the revised Guidance should remain ship-independent, agreed to the draft MSC circular on Revised Guidance to the master for avoiding dangerous situations in adverse weather and sea conditions, set out in annex 6, for submission to MSC 82 for approval.

5.21 In the course of the discussion, the Sub-Committee took note of the view expressed by the delegation of Venezuela that references to the Beaufort Scale should be included in the revised Guidance in order to provide a basis for guidance to the master.

### **Guidelines for the approval of stability instrument software**

5.22 The Sub-Committee agreed to the draft MSC circular on Guidelines for the approval of stability instruments, set out in annex 7, for submission to MSC 82 for approval. In this context, the Sub-Committee took into consideration the recently published ISO standard (ISO 16155:2006, Ship and marine technology – Computer applications – Shipboard loading instruments) and agreed that its provisions provided no advantage over the provisions of the above draft Guidelines.

## **Review of the plan of action**

5.23 The Sub-Committee agreed to the Updated plan of action for the intact stability work, set out in annex 8, based on the progress made during the session.

## **Establishment of the correspondence group**

5.24 The Sub-Committee re-established the Correspondence Group on Intact Stability, under the co-ordination of Germany\*, to continue its work intersessionally, with the following terms of reference:

- .1 to develop draft amendments to the 1974 SOLAS Convention and the 1988 LL Protocol, making the IS Code mandatory under these instruments;
- .2 to further examine, considering pros and cons, the matter relating to the inclusion of an equivalency section in part A of the draft revised IS Code and make appropriate recommendations;
- .3 to consider the problem that some ships, especially those with wide beam and small depth, have difficulties in complying with the criterion of the minimum angle of 25° of the maximum GZ value (IS Code, part A, paragraph 2.2.3) and to recommend an appropriate solution;
- .4 to continue the work on the items contained in the Updated plan of action for intact stability work, set out in annex 8, taking into account documents SLF 49/5/2, SLF 49/5/4, SLF 49/5/5, SLF 49/5/6, SLF 49/5/7 and Corr.1, SLF 49/5/8, SLF 49/5/9, SLF 49/5/10, SLF 49/5/12, SLF 49/INF.3, SLF 49/INF.6 and SLF 49/INF.7 and relevant documents from previous sessions;
- .5 to make recommendations and prepare documentation for any amendments to the work programme, if necessary, such as renaming the item following completion of the revised IS Code; and
- .6 to submit a report to SLF 50.

5.25 With regard to the draft revised IS Code, the delegation of Germany offered to prepare the text of the draft revised Code, in a format used for IMO instruments, on the basis of document SLF 49/5 taking into account modifications agreed by the IS Working Group (SLF 49/WP.2, annex 1) and relevant decisions taken by the Sub-Committee and submit it to SLF 50.

---

\* **Co-ordinator:**

Mr. Christian Mains  
Naval Architect  
Germanischer Lloyd  
Vorsetzen 35  
D-20459 Hamburg  
Germany  
Tel: + 49 (0) 40-3 6149-738  
Fax: + 49 (0) 40-3 6149-200  
E-mail: Christian.Mains@gl-group.com



## **6 SAFETY OF SMALL FISHING VESSELS**

### **General**

6.1 The Sub-Committee recalled that SLF 48 had established a correspondence group to develop a consolidated draft text of the Safety standards for small fishing vessels covering decked fishing vessels of less than 12 m in length and undecked fishing vessels of any length, and also agreed to establish, at this session, a Working Group on Safety of Small Fishing Vessels.

6.2 Following consideration of the report of the correspondence group (SLF 49/6, SLF 49/6/1, SLF 49/6/2 and SLF 49/6/3) submitted by South Africa, the Sub-Committee approved the report in general and, in particular:

- .1 noted the progress made during the intersessional period;
- .2 agreed to the group's proposal to use design and distance categories;
- .3 noted the views of the correspondence group concerning the title of the draft document for referral of this to the working group with a view to finalizing this item;
- .4 noted the information provided by the correspondence group regarding the completion date; and
- .5 noted the comments provided by ILO, regarding the participation in the development of the new standards as well as the proposed ILO convention and recommendation concerning work in the fishing sector.

6.3 With regard to the draft Safety standards for small fishing vessels prepared by the correspondence group, the Sub-Committee, bearing in mind that the draft Safety standards would be considered in detail by the working group, referred the above documents to the working group.

6.4 In the course of the consideration of the report of the correspondence group (SLF 49/6), the Sub-Committee noted that all members of the correspondence group were invited to two informal meetings, where interested members of the group met to review the documents and to prepare the report to SLF 49. In this respect, a number of delegations expressed their concern, because the Committee's Guidelines on the organization and method of work clearly state that "no official meetings of members of correspondence groups should be held without prior approval of the Committee(s)". Subsequently, the Sub-Committee agreed that the Committee's Guidelines should be applied properly and correspondence groups should not make any arrangements which may undermine the procedure established for correspondence groups under the Committee's Guidelines.

### **Statements by the representatives of ILO and FAO**

6.5 The representative from ILO stated that its Governing Body had authorized the participation of the Organization in the development of the non-binding small fishing vessel safety standards and that ILO looked forward to future participation by both workers and employers in this work. He further advised that in June 2007, the 96<sup>th</sup> Session of the International Labour Conference would hold a third discussion of a proposed Convention and

Recommendation on Work in the Fishing Sector, and had sent a report and questionnaire\* to all Member States, with replies due in September, requesting comments on such issues as length/gross tonnage equivalency figures and dimensions of crew accommodation and furnishings, issues of possible interest to, and within the expertise, of the SLF Sub-Committee's delegates.

6.6 The representative from FAO stated that the fishing industry suffers in excess of 24,000 fatalities per year and that the large majority of them occur on small fishing vessels. As there are, currently, no international safety standards for small fishing vessels covering decked fishing vessels of less than 12 m in length and undecked fishing vessels of any length, he stressed the need to develop the safety standards for such vessels.

### **Establishment of the working group**

6.7 The Sub-Committee established the Working Group on Safety of Small Fishing Vessels and instructed it, taking into account comments made and decisions taken in plenary, to:

- .1 working through the week, progress further the draft Safety standards for small fishing vessels, set out in documents SLF 49/6/1, SLF 49/6/2 and SLF 49/6/3, taking into account the report of the correspondence group (SLF 49/6); and
- .2 consider whether it is necessary to establish the correspondence group and, if so, prepare draft terms of reference for the group, for consideration by plenary.

### **Report of the working group**

6.8 Having received the report of the working group (SLF 49/WP.3), the Sub-Committee approved it in general and took action as indicated in the following paragraphs.

6.9 The Sub-Committee noted that the group had considered the draft Safety standards for small fishing vessels contained in documents SLF 49/6/1, SLF 49/6/2 and SLF 49/6/3 as prepared by the correspondence group and had amended chapters of the draft Safety standards (including the available annexes) as needed. These amendments to the draft Safety standards will be included in part 2 of the working group's report. The Sub-Committee also agreed that the outstanding annexes and any minor modifications to the draft Safety standards should be submitted to the correspondence group by 3 November 2006 at the latest.

6.10 The Sub-Committee noted that the group had also considered document SLF 49/6 which required further analysis of the title "Safety standards" and, having discussed the recommendation of the group, agreed to the title "Safety recommendations for decked fishing vessels of less than 12 metres in length and undecked fishing vessels".

6.11 As recommended by the group with regard to the comment by the delegation of Finland in plenary, the Sub-Committee noted that:

- .1 the Intact Stability Code does not apply to vessels of less than 24 m in length and is, therefore, outside the remit of the Safety recommendations; and

---

\* <http://www.ilo.org/public/english/standards/relm/ilc/ilc96/reports.htm>

- .2 small vessels, due to their nature, will benefit by having the maximum righting lever  $GZ_{max}$  at an angle preferably exceeding  $30^\circ$ ,

and, therefore, agreed not to amend section 3.2.1.3 of the draft Safety recommendations.

6.12 The Sub-Committee also noted that the group, being mindful of the draft proposed Convention and Recommendations on Work in the Fishing Sector (to be completed in June 2007), which is currently under consideration at ILO, had recognized that the draft Safety recommendations for decked fishing vessels of less than 12 m in length and undecked fishing vessels should be revisited in order to ensure consistency.

6.13 The Sub-Committee, in concurring with the group, agreed to refer to the Working Group on Intact Stability the information regarding fishing vessel stability in the Code of Safety for Fishermen and Fishing Vessels, 2005. It was agreed that the provisions of paragraphs 1.2, 1.3 and 1.4 of section III and appendix 10 of that Code should be taken into account when preparing text concerning fishing vessel stability in the draft revised Intact Stability (IS) Code. Furthermore, consideration should be given to insertion of appendix 7 of part A of the Fishing Vessel Safety Code in the revised IS Code.

6.14 The Sub-Committee noted the comments of the group on the issue of the term “fishermen” contained in the draft Safety recommendations and whether it should be a gender neutral.

### **Establishment of the correspondence group**

6.15 The Sub-Committee agreed to re-establish the Correspondence Group on Safety of Small Fishing Vessels, under the co-ordination of South Africa\*, with the following terms of reference:

- .1 to finalize the draft Safety recommendations, taking into account part 2 of the working group’s report from SLF 49; and
- .2 to submit the report to SLF 50.

## **7 HARMONIZATION OF DAMAGE STABILITY PROVISIONS IN OTHER IMO INSTRUMENTS**

### **General**

7.1 The Sub-Committee recalled that SLF 48, in considering IMO instruments in which damage stability provisions should be based on probabilistic principles, with regard to:

---

\* **Co-ordinator:**

Captain Nigel T Campbell  
South African Maritime Safety Authority  
P.O. Box 3914  
North End, Port Elizabeth, 6065  
South Africa  
Tel: +27 (0)41 585 0051  
Fax: +27 (0)41 582 1213  
e-mail: [ncampbell@samsa.org.za](mailto:ncampbell@samsa.org.za)  
CG website: [www.sigling.is/FVS-ISCG](http://www.sigling.is/FVS-ISCG)

- .1 the 2000 HSC Code, the OSV Guidelines and the MODU Code, had agreed not to pursue the matter further as adequate damage statistics justifying the need for such a harmonization were not available;
- .2 MARPOL 73/78, the IBC Code and the IGC Code, had agreed that these instruments should not be subject to the harmonization as the work by the SDS Working and Correspondence Groups had mainly focused on dry cargoes and there is no compelling need to extend the probabilistic approach to include ships carrying bulk liquid cargoes and criteria associated with the prevention of marine pollution;
- .3 the INF Code and the SPS Code, had agreed to consider further harmonization through amendments to these Codes, and also agreed that the relevant amendments to the SPS Code should be developed under the work programme item on “Review of the SPS Code”; and
- .4 the 1988 LL Protocol, realizing that the desired harmonization may be achieved by way of deletion of the footnote relating to regulation 4.1 of the revised SOLAS chapter II-1, which refers to the 1966 LL Convention and the 1988 LL Protocol, had agreed to give further consideration to the matter only for type “B” ships assigned reduced freeboards, carrying solid bulk cargoes.

7.2 Subsequently, SLF 48 agreed to instruct the SDS Correspondence Group, taking into account the above conclusions, to consider the matter further; to develop appropriate proposals for revisions to the INF and SPS Codes and to the revised SOLAS chapter II-1; and to report on the outcome to this session.

7.3 The Sub-Committee had for its consideration under this agenda item:

- .1 document SLF 49/7 (the report of the SDS Correspondence Group) submitted by Sweden and the United States;
- .2 document SLF 49/7/1 (Japan), presenting a technical verification of the safety level of the requirements for the damage stability in the 1988 LL Protocol and the revised SOLAS chapter II-1, and opposing the deletion of the footnote relating to regulation 4.1 of the revised SOLAS chapter II-1, regarding the 1988 LL Protocol;
- .3 document SLF 49/7/2 (Germany), stating that for ships with cargo compartments of limited length, it may not be sufficient, in all cases, to comply with the damage stability requirements of SOLAS chapter II-1 and, therefore, proposing to delete footnotes .6 and .7 relating to regulation 4.1 of the revised SOLAS chapter II-1; and
- .4 document SLF 49/7/3 (China), commenting on the report of the SDS Correspondence Group regarding the harmonization of the damage stability requirements in the revised SOLAS chapter II-1 with that contained in the 1966 LL Convention, suggesting to keep .6 and .7 of the footnote relating to regulation 4.1 of the revised SOLAS chapter II-1.

7.4 Having noted that the matters relating to the SPS Code would be dealt with under agenda item 11 (Review of the SPS Code), the Sub-Committee agreed to take the outcome of the group on the issues in the context of the aforementioned agenda item.

7.5 In considering the outcome of the group with regard to deleting the footnote relating to regulation 4.1 of the revised SOLAS chapter II-1, referring to the 1966 LL Convention and the 1988 LL Protocol, and comments thereon submitted in the aforementioned documents, whereas a majority was in favour of retaining the footnote, a concern was expressed with regard to the safety of ships carrying deck cargoes affecting the actual GM values. Subsequently, the Sub-Committee agreed, in principle, to the compromise solution that the footnote in the revised SOLAS chapter II-1 be retained with some modifications limiting the application of the LL regulations to bulk carriers which do not carry deck cargoes affecting the GM values substantially.

7.6 Having noted that no comments were made regarding the INF Code, the Sub-Committee agreed to refer above documents and comments made in plenary to the SDS Working Group for further consideration, with a view to preparing draft amendments to the footnote in the revised SOLAS chapter II-1, referring to the 1966 LL Convention and the 1988 LL Protocol, and to the INF Code.

### **Instructions to the SDS Working Group**

7.7 The Sub-Committee agreed to instruct the SDS Working Group, established under agenda item 3, taking into account comments made and decisions taken in plenary, to:

- .1 if time permits, consider the correspondence group's report (SLF 49/7), together with documents SLF 49/7/1, SLF 49/7/2 and SLF 49/7/3, and prepare draft amendments to the footnote relating to the revised SOLAS regulation II-1/4.1, the 1988 LL Protocol as appropriate and to the INF Code, and make recommendations on the extension of the target completion date for the item; and
- .2 prepare any appropriate draft instructions for the SDS Correspondence Group, if necessary, to progress the work on the matter.

### **Report of the working group**

7.8 Having considered the part of the report of the working group (SLF 49/WP.1) relating to the item, the Sub-Committee took action as outlined in the following paragraphs.

7.9 The Sub-Committee considered amendments to the footnote relating to the revised SOLAS regulation II-1/4.1, referring to the 1966 LL Convention and the 1988 LL Protocol, and agreed that the words "except ships intended for the carriage of deck cargo" should be added at the end of .6 and .7 of the footnote.

7.10 Concerning the harmonization of the INF Code, the Sub-Committee considered the relevant part of the report of the correspondence group (SLF 49/7) and agreed that:

- .1 regarding INF Code regulation 2.1 (Class INF 1 ships), the existing standard should be maintained (i.e., the damage stability shall be to the satisfaction of the Administration) and that no editorial changes were necessary to account for the revised SOLAS chapter II-1;

- .2 regarding INF Code regulation 2.3 (Class INF 3 ships), the existing standard should be maintained (i.e., a ship shall comply with either the IBC Code standard or the “scaled-up” cargo ship damage stability standard) and that no editorial changes were necessary to account for the revised SOLAS chapter II-1; and
- .3 the INF Code should be amended as follows:
  - .3.1 in regulation 2.2.1, the words “Part B” are replaced by the words “Part B-1”; and
  - .3.2 in regulations 2.2 and 2.3, the following sentence is added at the end of paragraphs 2.2.2 and 2.3.2 respectively:

“For ships less than 80 m in length, the subdivision index R at 80 m shall be used.”

7.11 Consequently, the Sub-Committee, agreed to the draft amendments to the INF Code, set out in annex 9, for submission to MSC 82 for approval and subsequent adoption at MSC 83 and recommended to the Committee that the entry-into-force date of the proposed INF Code amendments should be as close as practicable to the entry-into-force date of the revised SOLAS chapter II-1, i.e., 1 January 2009.

### **Completion of the item**

7.12 Since work on the item has been completed, the Sub-Committee agreed to invite the Committee to delete it from the work programme of the Sub-Committee.

## **8 CONSIDERATION OF IACS UNIFIED INTERPRETATIONS**

8.1 The Sub-Committee recalled that the Committee, in including the above item in the sub-committees’ work programme, had instructed the sub-committees to review the IACS unified interpretations which fall within their purview and to prepare, on the basis of those unified interpretations, appropriate interpretations to the respective IMO instruments for approval by the Committee and dissemination to Member Governments for the latter to use when applying relevant provisions of such IMO instruments.

8.2 The Sub-Committee, noted that no documents had been submitted to this session under this agenda item.

## **9 REVISION OF RESOLUTION A.266(VIII)**

### **General**

9.1 The Sub-Committee recalled that SLF 48 had agreed that the following two issues should be included in the revision of resolution A.266(VIII) on Recommendation on a standard method for establishing compliance with the requirements for cross-flooding arrangements in passenger ships:

- .1 cross-flooding times through ducts; and
- .2 restrictive effect of counter pressure in tanks.

9.2 The Sub-Committee also recalled that SLF 48, having noted that the working group, due to time constraints, was not able to develop a draft revised Recommendation on a standard method for establishing compliance with the requirements for cross-flooding arrangements in passenger ships (resolution A.266(VIII)), had instructed the SDS Correspondence Group to revise the information in resolution A.266(VIII) to include cross-flooding arrangements other than pipes and air ventilation to assure efficient cross-flooding, also including information in the Explanatory Notes for harmonized SOLAS chapter II-1, and to submit a report to this session.

9.3 The Sub-Committee considered the report of the SDS Correspondence Group (SLF 49/9) submitted by Sweden and the United States and, having agreed that the revised Recommendation on a standard method for establishing compliance with the requirements for cross-flooding arrangements in passenger ships (resolution A.266(VIII)) should remain as an independent instrument and that the Explanatory Notes should refer to the revised Recommendation in a footnote, referred the correspondence group's report to the SDS Working Group for detail consideration and development of the draft revised Recommendation.

### **Instructions to the SDS Working Group**

9.4 The Sub-Committee agreed to instruct the SDS Working Group, established under agenda item 3, taking into account comments made and decisions taken in plenary, to:

- .1 if time permits, consider the correspondence group's report (SLF 49/9) and develop draft revised Recommendation on a standard method for establishing compliance with the requirements for cross-flooding arrangements in passenger ships (resolution A.266(VIII)) and the associated draft MSC resolution, bearing in mind the Sub-Committee's decision on the status of the revised recommendation;
- .2 prepare draft instructions for the SDS Correspondence Group, if necessary, to progress the work on the matter.

### **Report of the working group**

9.5 Having considered the part of the report of the working group (SLF 49/WP.1) relating to the item, the Sub-Committee took action as outlined in the following paragraphs.

9.6 The Sub-Committee noted that the group had appreciated the significant contributions submitted to the correspondence group, however, due to time constraints, had not been able to consider the issue and had recommended that the SDS Correspondence Group be tasked with the further consideration; and invited the Committee to extend the target completion date to 2007.

9.7 Consequently, the Sub-Committee instructed the SDS Correspondence Group established under agenda item 3 to finalize the draft revised Recommendation on a standard method for establishing compliance with the requirements for cross-flooding arrangements in passenger ships (resolution A.266(VIII)) and the associated draft MSC resolution, based on the correspondence group's report (SLF 49/9) and comments and decisions made in plenary (see paragraph 3.23).

## **10 TONNAGE MEASUREMENT OF OPEN-TOP CONTAINERSHIPS**

### **General**

10.1 The Sub-Committee recalled that SLF 48 had agreed to amend the provisional formula for reduced gross tonnage for open-top containerships prescribed in TM.5/Circ.4, based on document SLF 48/12/2, and had established a correspondence group to finalize the revised text of the circular.

10.2 In this context, the Sub-Committee noted that, with regard to the entry for the above-mentioned reduced gross tonnage in the tonnage certificate, SLF 48 had confirmed that it should be placed in the "Remarks" column on the reverse side of the International Tonnage Certificate (1969) and had not agreed to the proposal to develop a supplement to the certificate indicating the reduced gross tonnage.

10.3 The Sub-Committee considered the report of the correspondence group (SLF 49/10) submitted by Germany, inviting the Sub-Committee to agree to the proposed draft amendment to TM.5/Circ.5 as presented in the annex to the document and, in particular, to note the views regarding the definition of "open-top containerships" and decide as appropriate, and also to endorse the proposed development of an MSC resolution urging the implementation of the revised TM.5/Circ.5.

10.4 Following discussion of the proposals by the correspondence group, the Sub-Committee, having agreed, in general, to the proposal for tonnage measurement of open-top containerships, as given in the annex to document SLF 49/10, in particular:

- .1 agreed to the definition of "open-top containership", as outlined in paragraph 7 of document SLF 49/10. In the course of the discussion, as a question was raised regarding the figure 66.7%, representing the ratio of open-top cargo hatches, the Sub-Committee noted that the figure was to mean more than two-thirds; and
- .2 agreed that an MSC resolution concerning the tonnage measurement of open-top containerships should be developed, instead of the development of the amendments to TM.5/Circ.5 and an appropriate MSC resolution urging the implementation of the proposed amendments to the circular.

### **Establishment of the drafting group**

10.5 In order to progress the work on the item, the Sub-Committee established the Drafting Group on Tonnage measurement of open-top containerships, and instructed it, taking into account comments made and decisions taken in plenary, to prepare a draft MSC resolution concerning tonnage measurement of open-top containerships, based on document SLF 49/10.

### **Report of the drafting group**

10.6 Having received the report of the drafting group (SLF 49/WP.4), the Sub-Committee approved it in general and, in particular, agreed to the draft MSC resolution on Recommendations concerning tonnage measurement of open-top containerships, set out in annex 10, for submission to MSC 82 for consideration with a view to adoption.



## **Completion of the item**

10.7 The Sub-Committee concluded that the work on the item had been completed and invited the Committee to delete the item from the Sub-Committee's work programme.

## **11 REVIEW OF THE SPS CODE**

### **General**

11.1 The Sub-Committee recalled that SLF 48, in the context of the item on "Harmonization of damage stability provisions in IMO instruments", had agreed, with regard to the SPS Code, to consider further harmonization through amendments to the Code which should be developed under this agenda item.

11.2 The Sub-Committee also recalled that SLF 48 had instructed the SDS Correspondence Group to develop appropriate proposals for revisions to the SPS Code and report to this session, and had agreed to establish, at this session, a drafting group, taking into account the outcome of the SDS Correspondence Group.

11.3 The Sub-Committee had for its consideration the part of the report of the SDS Correspondence Group (SLF 49/7) relating to the item, submitted by Sweden and the United States; and document SLF 49/11 (Norway), proposing draft amendments to the SPS Code based on the use of the subdivision and damage stability requirements contained in the revised SOLAS chapter II-1.

### **Proposals for amendments to the SPS Code**

11.4 In considering the options for damage stability categories and criteria proposed by the correspondence group (SLF 49/7), the Sub-Committee, having agreed that it would be premature to decide on the preferred option, agreed to refer the matter to a correspondence group for further consideration.

11.5 Following debate of the proposals by Norway (SLF 49/11), presenting possible amendments to the SPS Code, the Sub-Committee, although recognizing that some issues are not within its purview, preliminarily examined the proposals and, with regard to:

- .1 the terms "special personnel" used in the current Code and "persons", agreed that it would be more appropriate for the DE Sub-Committee to consider the issue due to its general nature and, while considering that the use of "persons" had some merit but that changes might need to be made in conjunction with other sub-committees concerned, also agreed that both terms should appear in square brackets for the time being;
- .2 the probabilistic subdivision and damage stability requirements, agreed that the SPS Code harmonization should be based on the subdivision and damage stability requirements of the revised SOLAS chapter II-1 in conjunction with the options to be agreed on damage stability categories proposed by the correspondence group;
- .3 whether machinery space exemption in the current SPS Code should be deleted, agreed that such exemption was not consistent with the damage stability requirements based on the probabilistic approach;

- .4 whether deterministic requirements should be included in the Code in addition to probabilistic requirements, agreed that no deterministic requirements are needed; and
- .5 intact stability, noted that the revised SPS Code would be referred in to the IS Code.

11.6 As some of the issues raised by Norway in document SLF 49/11 were of a general nature, the Sub-Committee agreed that document SLF 49/11 should be referred to the DE Sub-Committee for consideration within its competence and action as appropriate.

### **Establishment of the correspondence group**

11.7 Subsequently, the Sub-Committee agreed to establish the Correspondence Group on Review of the SPS Code, under the co-ordination of Australia\*, and instructed it to develop draft amendments to the SPS Code, on the basis of documents SLF 49/7 and SLF 49/11, taking into account the above decisions and comments made in plenary, and to report to SLF 50.

11.8 In view of the above developments, the Sub-Committee agreed to invite the Committee to extend the target completion date of the item to 2007 and requested the Secretariat to inform the DE Sub-Committee of the above outcome.

## **12 ANALYSIS OF DAMAGE CARDS: REVISION OF THE IMO DAMAGE CARD**

12.1 The Sub-Committee recalled that SLF 46 had agreed with the recommendation of the SDS Working Group based on the proposal by Germany (SLF 46/3/7), that the IMO damage card contained in annex 5 to MSC/Circ.953 – MEPC/Circ.372 (which was later superseded by MSC-MEPC.3/Circ.1) should be revised, and had invited the Committee to include an appropriate item in the Sub-Committee's work programme.

12.2 The Sub-Committee also recalled that SLF 48, having noted that no documents were submitted under this agenda item, invited Member Governments and international organizations to submit, to this session, appropriate comments and proposals on the proposed revisions of the IMO damage card annexed to document SLF 46/3/7, with a view to finalizing the revision of the format of the IMO damage card.

12.3 As no comments or further proposals for the proposed revisions of the IMO damage card annexed to document SLF 46/3/7 had been submitted to this session, the Sub-Committee, following a brief discussion, agreed to the draft Revised form of damage card, set out in annex 11, and decided to refer it to the FSI Sub-Committee for consideration and appropriate

---

\* **Co-ordinator:**

Mrs. Kate Linley  
Principal Adviser – Cargo Marine Standards  
Maritime Safety & Environmental Strategy  
Australian Maritime Safety Authority  
Level 1, 25 Constitution Avenue  
GPO Box 2181, Canberra ACT 2601  
Tel.: +61 2 6279 5042  
Fax.: +61 2 6279 5966  
Email: [kate.linley@amsa.gov.au](mailto:kate.linley@amsa.gov.au)

action, aiming at the development of the respective amendments to MSC-MEPC.3/Circ.1, for approval by the Committee.

### **13 REVISION OF MSC/CIRC.650**

#### **General**

13.1 The Sub-Committee recalled that SLF 48 had started its deliberation on this item in pursuance of the Committee's instruction to clarify the meaning of the term "existing cargo ships" in MSC/Circ.650 on Interpretation of alterations and modifications of a major character (in particular, in view of the extension of the application of the subdivision and damage stability requirements for cargo ships, specified in part B-1 of SOLAS chapter II-1 to cover ships less than 80 m or 100 m in length), since, whilst some Administrations were of the opinion that existing ships are limited to ships built before 1 February 1992 or 1 July 1998 respectively, depending on their length of 100 m and 80 m, and, therefore, any lengthening from below to above the application limits of 100 m or 80 m respectively, would require the application of SOLAS chapter II-1, part B-1, others were of the opinion that the circular was applicable also to ships built after 1 February 1992 or 1 July 1998 respectively, on their lengthening from below to above the application limits of 100 m or 80 m respectively.

13.2 It was also recalled that SLF 48, in considering document SLF 48/17 (Republic of Korea), had agreed to forward it, together with the modified additional sentence proposed by the delegation of the United Kingdom for inclusion in the revised MSC/Circ.650, to the SDS Correspondence Group to develop the appropriate revision of MSC/Circ.650.

#### **Justification for a new work programme item**

13.3 The Sub-Committee considered the report of the SDS Correspondence Group (SLF 49/13) submitted by Sweden and the United States and, with regard to the issue raised by the correspondence group concerning the treatment of "alterations and modifications of a major character" for passenger and cargo ships the keels of which are laid before 1 January 2009, when the revised SOLAS chapter II-1 enters into force, decided that the issue should be dealt with separately from the Explanatory Notes and that an appropriate new item should be included in the work programme of the Sub-Committee.

13.4 Consequently, the Sub-Committee invited interested delegations, in consultation with the Secretariat, to draft a justification for a new work programme item for consideration by MSC 82 and, having considered document SLF 49/WP.5, agreed to the justification for a proposal for a new work programme item, set out in annex 1, and invited the Committee, taking into account the aforementioned justification, to include a new item on "Interpretation of alterations and modifications of a major character under the revised SOLAS chapter II-1" in the Sub-Committee's work programme.

#### **Instructions to the SDS Working Group**

13.5 Concerning the revision of MSC/Circ.650, the Sub-Committee agreed to instruct the SDS Working Group, established under agenda item 3, taking into account comments made and decisions taken in plenary, to prepare, if time permits, the revised Interpretation of alterations and modifications of a major character (MSC/Circ.650), based on the correspondence group's report (SLF 49/13).

## Report of the working group

13.6 Having considered the part of the report of the working group (SLF 49/WP.1) relating to the item, the Sub-Committee noted that the group had generally agreed with the revised Interpretation of alterations and modifications of a major character (MSC/Circ.650) as prepared by the correspondence group (paragraph 9 of SLF 49/13), but, due to time constraints, had not been able to consider the proposal in detail. Consequently, the Sub-Committee agreed that the proposal should be considered further at SLF 50 and invited the Committee to extend the target completion date for the item to 2007.

## 14 WORK PROGRAMME AND AGENDA FOR SLF 50

### Work programme and agenda for SLF 50

14.1 Taking into account the progress made at this session and the provisions of the agenda management procedure contained in paragraphs 3.11 to 3.23 of the Guidelines on the organization and method of work (MSC/Circ.1099 – MEPC/Circ.405), the Sub-Committee revised its work programme (SLF 49/WP.6) based on that approved by MSC 81 (SLF 49/2/1, annex) and prepared the proposed revised work programme and provisional agenda for SLF 50. While reviewing the work programme, the Sub-Committee agreed to invite the Committee to:

- .1 delete the following work programme items, as work on them has been completed:
  - .1.1 item 2.1 - Revision of the IMO damage card;
  - .1.2 item H.3 - Passenger ship safety;
  - .1.3 item L.1 - Harmonization of damage stability provisions in other IMO instruments, including the 1993 Torremolinos Protocol (probabilistic method); and
  - .1.4 item L.3 - Tonnage measurement of open-top containerships;
- .2 extend the target completion dates of the following work programme items:
  - .2.1 item H.1 - Development of explanatory notes for harmonized SOLAS chapter II-1, to 2008;
  - .2.2 item H.4 - Review of the SPS Code, to 2007;
  - .2.3 item L.2 - Revision of resolution A.266(VIII), to 2007; and
  - .2.4 item L.4 - Revision of MSC/Circ.650, to 2007;
- .3 replace the number of sessions needed for completion of the following work programme item by the target completion date, as the item has been included in the provisional agenda for SLF 50:
  - .3.1 item H.8 - Time dependant survivability of passenger ships in damaged condition 2009;

- .4 include the following new items in the Sub-Committee's work programme, taking into account the justification:
  - .4.1 item H.8 - Interpretation of alterations and modifications of a major character under the revised SOLAS chapter II-1 2007;
  - .4.2 item H.9 - Guidance on the impact of open watertight doors on survivability under regulation 22.4 of the revised SOLAS chapter II-1 2008;
- .5 renumber the work programme items accordingly.

The Committee was invited to approve the proposed revised work programme of the Sub-Committee and draft provisional agenda for SLF 50, set out in annex 12.

### **Arrangements for the next session**

14.2 The Sub-Committee agreed to establish, at SLF 50, working groups on the following subjects:

- .1 subdivision and damage stability;
- .2 intact stability; and
- .3 safety of small fishing vessels,

and drafting groups on Review of the SPS Code and on Guidance on the impact of open watertight doors, subject to the decision of the Committee on the inclusion of the latter item in the Sub-Committee's work programme (see paragraph 3.11).

14.3 The Sub-Committee agreed that the SDS Working Group should commence its work at the start of the next meeting (i.e., at 9.30 a.m. on Monday, 30 April 2007) on the basis of the draft terms of reference to be prepared by the Chairman, pending formal discussion of those terms of reference under the agenda item on "Development of explanatory notes for harmonized SOLAS chapter II-1".

### **Date of the next session**

14.4 The Sub-Committee noted that the fiftieth session of the Sub-Committee had been tentatively scheduled to take place in London, at the International Coffee Organization, from 30 April to 4 May 2007.

## **15 ELECTION OF CHAIRMAN AND VICE-CHAIRMAN FOR 2007**

15.1 The Sub-Committee, in accordance with the Rules of Procedure of the Maritime Safety Committee, unanimously re-elected Mr. R. Gehling (Australia) as Chairman and Mr. Z. Szozda (Poland) as Vice-Chairman, both for 2007.

## 16 ANY OTHER BUSINESS

16.1 The Sub-Committee noted that no documents had been submitted under this agenda item.

## 17 ACTION REQUESTED OF THE COMMITTEE

17.1 The Maritime Safety Committee is invited to:

- .1 include a new item on “Guidance on the impact of open watertight doors on survivability under regulation 22.4 of the revised SOLAS chapter II-1” in the Sub-Committee’s work programme, taking into account the justification for the proposal for a new work programme item (paragraph 3.11 and annex 1);
- .2 consider including, in the DE Sub-Committee’s work programme, a new item on the development of guidance to ensure consistent policy for determining the need for watertight doors to remain open during navigation and take action as appropriate (paragraph 3.11 and annex 1);
- .3 approve the draft MSC circular on Interim Explanatory Notes to the SOLAS chapter II-1 subdivision and damage stability regulations (paragraph 3.14 and annex 2);
- .4 note that, in dealing with the relevant instructions of MSC 81, the Sub-Committee agreed that no definitions of the terms “steps” and “recesses” referred to in the new SOLAS regulation II-1/12 are necessary (paragraph 3.19);
- .5 note that, concerning the definition of *unfavourable conditions of trim and list*, as prepared by FP 50 for inclusion in SOLAS regulation III/3, the Sub-Committee concluded that the text of the definition is not appropriate and should be reconsidered, and invited Member Governments to submit, to MSC 82, concrete text proposals for relevant modifications to the definition (paragraph 3.22);
- .6 consider the proposed revised draft SOLAS regulations II-1/8-1 and II-1/22-1 and take action, as appropriate, subject to the decision under subparagraph .7 below (paragraphs 4.10 to 4.23 and annex 3);
- .7 consider, when adopting the set of amendments related to the passenger ship safety initiative, the Sub-Committee’s views that the revised SOLAS chapter II-1 should be readopted with the inclusion of the revised draft regulations II-1/8-1 and II-1/22-1 referred to in subparagraph .6 above and that the draft amendments to SOLAS chapters II-1, II-2 and III related to the passenger ship safety initiative should be adopted as a package with the expected entry-into-force date of 1 January 2009, and take action as appropriate (paragraph 4.24);
- .8 consider the proposed modifications to draft SOLAS regulations II-2/21 and II-2/23, when adopting the draft amendments to SOLAS chapter II-2 and take action as appropriate (paragraph 4.25 and annex 3);
- .9 approve the draft MSC circular on Performance standards for the systems and services to remain operational on passenger ships for safe return to port and orderly evacuation and abandonment after a casualty, simultaneously with the

- adoption of the draft amendments to SOLAS chapter II-2 related to passenger ship safety initiative (paragraph 4.27 and annex 4);
- .10 approve the draft MSC circular on Explanatory Notes to the Interim Guidelines for alternative assessment of the weather criterion (paragraph 5.16 and annex 5);
  - .11 note the Sub-Committee's conclusion that both the 1974 SOLAS Convention and the 1988 LL Protocol should be amended to make part A of the Intact Stability Code mandatory, in order to gain the widest application of the mandatory criteria of the IS Code (paragraph 5.17);
  - .12 approve the draft MSC circular on Guidance to the master for avoiding dangerous situations in adverse weather and sea conditions (paragraph 5.20 and annex 6);
  - .13 approve the draft MSC circular on Guidelines for the approval of stability instruments (paragraph 5.22 and annex 7);
  - .14 note the Updated plan of action for the intact stability work, approved by the Sub-Committee (paragraph 5.23 and annex 8);
  - .15 note the progress made on safety of small fishing vessels, in particular, that the Sub-Committee agreed to the instrument's title "Safety recommendations for decked fishing vessels of less than 12 metres in length and undecked fishing vessels" (paragraphs 6.2 to 6.15);
  - .16 consider the Sub-Committee's decision with regard to the additional wording at the end of .6 and .7 of the footnote relating to the revised SOLAS regulation II-1/4.1 and take action as appropriate (paragraph 7.9);
  - .17 approve the draft amendments to the INF Code with a view to adoption at MSC 83, taking into account the recommendation regarding entry-into-force date (paragraph 7.11 and annex 9);
  - .18 adopt the draft MSC resolution on Recommendations concerning tonnage measurement of open-top containerships (paragraph 10.6 and annex 10);
  - .19 note the progress made on the review of the SPS Code, in particular, the Sub-Committee's referral of document SLF 49/11 and the outcome of its discussion thereon to the DE Sub-Committee for co-ordination purposes (paragraphs 11.5 and 11.6);
  - .20 note that the Sub-Committee finalized its work on the revised IMO damage card and forwarded it to the FSI Sub-Committee for appropriate action (paragraph 12.3 and annex 11);
  - .21 include a new item on "Interpretation of alterations and modifications of a major character under the revised SOLAS chapter II-1" in the Sub-Committee's work programme, taking into account the justification for the proposal for a new work programme item (paragraph 13.4 and annex 1);

- .22 approve the proposed revised work programme of the Sub-Committee and provisional agenda for SLF 50 (paragraph 14.1 and annex 12); and
- .23 approve the report in general.

\*\*\*



**ANNEX 1****JUSTIFICATION FOR THE PROPOSALS FOR NEW WORK PROGRAMME ITEMS  
(in accordance with MSC/Circ.1099 – MEPC/Circ.366)****INTERPRETATION OF ALTERATIONS AND MODIFICATIONS OF A MAJOR CHARACTER  
UNDER THE REVISED SOLAS CHAPTER II-1****1 Scope of the proposal**

- .1 Examine the term “alterations and modifications of a major character” in regulation 1 of the revised SOLAS chapter II-1 and develop an interpretation of the term to clarify its meaning aiming at implementation of the regulation in a uniform and consistent manner.
- .2 Consider the issues raised in document SLF 49/13 (Sweden and the United States) as to whether the treatment of existing cargo and passenger ships, following the entry into force of the revised SOLAS chapter II-1, on or after 1 January 2009, should be addressed in the revised SOLAS chapter II-1 or the current SOLAS chapter II-1.

**2 Compelling need**

A new work programme item is necessary to enable the Sub-Committee to develop an interpretation of alterations and modifications of a major character for existing cargo and passenger ships in the revised SOLAS regulation II-1/1 to remove the inconsistency and to implement the revised SOLAS chapter II-1 in a uniform manner. It should be noted that the Sub-Committee’s terms of reference in relation to the similar problem of amending MSC/Circ.650 do not cover the amendments of resolution MSC.194(80).

**3 Analysis of the issues involved, having regard to the costs to the maritime industry and global legislative and administrative burdens**

The purpose of this effort would be primarily to ensure consistent application of the requirements to be in force from 1 January 2009 so that they are uniformly applied by Administrations, and not to impose new ones; and, therefore, the costs to the maritime industry are anticipated to be minimal. The administrative burdens to the Organization and to Member States are anticipated to be minimal as well.

**4 Benefits**

Administrations and recognized organizations acting on their behalf will apply the aforementioned requirements in a uniform manner and ship owners and builders will benefit by being provided with consistent and unambiguous requirements.

**5 Priority and target completion date**

This matter should have a high priority since the issues constitute an unresolved concern for Administrations, recognized organizations and manufacturers, which have been raised in the SLF Sub-Committee under its existing agenda item on “Revision of MSC/Circ.650”. To harmonize the outcome of this item with that of the aforementioned existing item, its consideration should be commenced at SLF 50. It is expected that only one session will be

needed to properly deal with this matter, and the expected target completion date for the item is 2007 since the item should be finalized before the revised SOLAS chapter II-1 enters into force on 1 January 2009.

## **6 Specific indication of the action required**

Development of an interpretation of alterations and modifications of a major character under the revised SOLAS chapter II-1 adopted by resolution MSC.194(80), similar to MSC/Circ.650.

## **7 Remarks on the criteria for general acceptance**

- .1 Is the subject of the proposal within the scope of IMO's objectives? Yes.
- .2 Do adequate industry standards exist? No, this is a matter of clarification of mandatory IMO instruments.
- .3 Do the benefits justify the proposed action? Yes.

## **8 Identification of which subsidiary bodies are essential to complete the work**

The work should be able to be accomplished by the Sub-Committee on Stability and Load Lines and on Fishing Vessels Safety exclusively.

### **GUIDANCE ON THE IMPACT OF OPEN WATERTIGHT DOORS ON SURVIVABILITY UNDER REGULATION 22.4 OF THE REVISED SOLAS CHAPTER II-1**

## **1 Scope of the proposal**

- .1 Develop guidance on the survivability associated with open watertight doors for ships in the revised SOLAS regulation II-1/22.4.
- .2 Consider the issues raised in appendix 3 to document SLF 49/3 (Sweden and the United States) regarding the Explanatory Notes.

## **2 Compelling need**

A new work programme item is necessary to enable the Sub-Committee to develop guidance on the impact of open watertight doors on survivability of passenger ships in the revised SOLAS regulation II-1/1. It should be noted that the Sub-Committee's terms of reference in relation to the Explanatory Notes have a target date to complete the Interim Explanatory Notes and pass them to MSC 82. The Sub-Committee identified the complexity associated with a need for operational guidance to be prepared by the DE Sub-Committee on conditions where watertight doors "may be left open for the safe operation of the ship".

## **3 Analysis of the issues involved, having regard to the costs to the maritime industry and global legislative and administrative burdens**

The purpose of this effort would be primarily to ensure consistent application of the requirements to be in force from 1 January 2009 so that they are uniformly applied by

Administrations, and not to impose new ones; and, therefore, the costs to the maritime industry are anticipated to be minimal. The administrative burdens to the Organization and to Member States are anticipated to be minimal as well.

#### **4 Benefits**

Administrations and recognized organizations acting on their behalf will apply the aforementioned requirements in a uniform manner and ship owners and builders will benefit by being provided with consistent and unambiguous requirements.

#### **5 Priority and target completion date**

This matter should have a high priority since the issues constitute an unresolved concern for Administrations, recognized organizations and manufacturers, which have been raised in the SLF Sub-Committee in its related agenda item on Explanatory Notes. As the matter has been provisionally considered, it is expected that two sessions will be needed to properly deal with this matter, and the expected target completion date for the item is 2008 so that the item should be finalized well before the revised SOLAS chapter II-1 enters into force on 1 January 2009.

#### **6 Specific indication of the action required**

Develop guidance which would be either included in the Explanatory Notes or disseminated by means of an MSC circular, to ensure that Administrations apply a consistent methodology for determining compliance with SOLAS regulation II-1/22.4. The Sub-Committee has also recognized that the DE Sub-Committee needs to prepare guidance for Administrations to ensure consistent policy for determining the need for watertight doors “to remain open during navigation is essential to the safe and effective operation of ship’s machinery”.

#### **7 Remarks on the criteria for general acceptance**

- .1 Is the subject of the proposal within the scope of IMO’s objectives? Yes.
- .2 Do adequate industry standards exist? No, this is a matter of clarification of mandatory IMO instruments.
- .3 Do the benefits justify the proposed action? Yes.

#### **8 Identification of which subsidiary bodies are essential to complete the work**

8.1 The impact on stability aspects of the work should be able to be accomplished by the Sub-Committee on Stability and Load Lines and on Fishing Vessels Safety.

8.2 The work programme of the DE Sub-Committee should include a new item on the development of guidance to ensure consistent policy for determining the need for watertight doors to remain open during navigation.

\*\*\*



**ANNEX 2****DRAFT MSC CIRCULAR****INTERIM EXPLANATORY NOTES TO THE SOLAS CHAPTER II-1  
SUBDIVISION AND DAMAGE STABILITY REGULATIONS**

1 The Maritime Safety Committee, at its eightieth session (10 to 19 May 2005), adopted resolution MSC.194(80), containing, *inter alia*, amendments to SOLAS chapter II-1, replacing parts A (General), B (Subdivision and stability) and B-1 (Subdivision and damage stability provisions for cargo ships) with new harmonized subdivision and damage stability regulations based on a probabilistic concept. In adopting the new regulations, the Committee recognized the necessity of appropriate explanatory notes for their uniform interpretation and application.

2 To this end, the Maritime Safety Committee, at its [eighty-second session (29 November to 8 December 2006)], approved the Interim Explanatory Notes to the SOLAS chapter II-1 subdivision and damage stability regulations, set out in the annex to the present circular, as prepared by the Sub-Committee on Stability and Load Lines and on Fishing Vessels Safety at its forty-ninth session.

3 The Interim Explanatory Notes are intended to provide Administrations and the shipping industry with specific guidance to assist in the uniform interpretation and application of the new harmonized subdivision and damage stability regulations.

4 Member Governments are invited to use the Interim Explanatory Notes when applying the new harmonized subdivision and damage stability regulations (SOLAS chapter II-1, parts A, B, B-1, B-2, B-3 and B-4) adopted by resolution MSC.194(80) and to bring them to the attention of all parties concerned.

ANNEX

**INTERIM EXPLANATORY NOTES TO THE SOLAS CHAPTER II-1  
SUBDIVISION AND DAMAGE STABILITY REGULATIONS**

**Contents**

*Page\**

**Part A – INTRODUCTION** .....

**Part B – GUIDANCE ON INDIVIDUAL REGULATIONS** .....

Regulation 2 .....

Regulation 4 .....

Regulation 5 .....

Regulation 5-1 .....

Regulation 6 .....

Regulation 7 .....

Regulation 7-1 .....

Regulation 7-2 .....

Regulation 7-3 .....

Regulation 8 .....

Regulation 9 .....

Regulation 10 .....

Regulation 12 .....

Regulation 13 .....

Regulation 13-1 .....

Regulation 15 .....

Regulation 15-1 .....

Regulation 16 .....

Regulation 17 .....

Regulation 35-1 .....

Appendix – Guidelines for the preparation of subdivision and damage  
stability calculations .....

---

\* Page numbers to be inserted when circular is issued.

## PART A

### INTRODUCTION

1 The harmonized SOLAS regulations on subdivision and damage stability, as contained in revised SOLAS chapter II-1, are based on a probabilistic concept which uses the probability of survival after collision as a measure of ships' safety in a damaged condition. This probability is referred to as the "attained subdivision index A" in the regulations. This can be considered an objective measure of ship safety and, ideally, there would be no need to supplement this index by any deterministic requirements.

2 The philosophy behind the probabilistic concept is that two different ships with the same attained index are of equal safety and therefore there is no need for special treatment of specific parts of the ship, even if they are able to survive different damages. The only areas which are given special attention in these regulations are the forward and bottom regions which are dealt with by special subdivision rules provided for the cases of ramming and grounding.

3 Only a few deterministic elements, which were necessary to make the concept practicable, have been included. It was also necessary to include a deterministic "minor damage" on top of the probabilistic regulations for passenger ships to avoid ships being designed with what might be perceived as unacceptably vulnerable spots in some part of their length.

4 It is easily recognized that there are many factors that will affect the final consequences of hull damage to the ship. These factors are random and their influence is different for ships with different characteristics. For example, it would seem obvious that in ships of similar size carrying different amounts of cargo damages of similar extents may lead to different results because of differences in the range of permeability and draught during service. The mass and velocity of the ramming ship is obviously another random variable.

5 Due to this, the effect of a three-dimensional damage to a ship with given watertight subdivision depends on the following circumstances:

- .1 which particular space or group of adjacent spaces is flooded;
- .2 the draught, trim and intact metacentric height at the time of damage;
- .3 the permeability of affected spaces at the time of damage;
- .4 the sea state at the time of damage; and
- .5 other factors such as possible heeling moments due to unsymmetrical weights.

6 Some of these circumstances are interdependent and the relationship between them and their effects may vary in different cases. Additionally, the effect of hull strength on penetration will obviously have some effect on the results for a given ship. Since the location and size of the damage is random, it is not possible to state which part of the ship becomes flooded. However, the probability of flooding a given space can be determined if the probability of occurrence of certain damages is known from experience, that is, damage statistics. The probability of flooding a space is then equal to the probability of occurrence of all such damages which just open the considered space to the sea.

7 For these reasons and because of mathematical complexity as well as insufficient data, it would not be practicable to make an exact or direct assessment of their effect on the probability that a particular ship will survive a random damage if it occurs. However, accepting some approximations or qualitative judgments, a logical treatment may be achieved by using the probability approach as the basis of a comparative method for the assessment and regulation of ship safety.

8 It may be demonstrated by means of probability theory that the probability of ship survival should be calculated as a sum of probabilities of its survival after flooding each single compartment, each group of two, three, etc., adjacent compartments multiplied, respectively, by the probabilities of surviving such damages as lead to the flooding of the corresponding compartment or group of compartments.

9 If the probability of occurrence for each of the damage scenarios the ship could be subjected to is calculated and then combined with the probability of surviving each of these damages with the ship loaded in the most probable loading conditions, we can determine the attained index A as a measure for the ship's ability to sustain a collision damage.

10 It follows that the probability that a ship will remain afloat without sinking or capsizing as a result of an arbitrary collision in a given longitudinal position can be broken down to:

- .1 the probability that the longitudinal centre of damage occurs in just the region of the ship under consideration;
- .2 the probability that this damage has a longitudinal extent that only includes spaces between the transverse watertight bulkheads found in this region;
- .3 the probability that the damage has a vertical extent that will flood only the spaces below a given horizontal boundary, such as a watertight deck;
- .4 the probability that the damage has a transverse penetration not greater than the distance to a given longitudinal boundary; and
- .5 the probability that the watertight integrity and the stability throughout the flooding sequence is sufficient to avoid capsizing or sinking.

11 The first three of these factors are solely dependent on the watertight arrangement of the ship, while the last two depend on the ship's shape. The last factor also depends on the actual loading condition. By grouping these probabilities, calculation of the probability of survival, or attained index A, have been formulated to include the following probabilities:

- .1 the probability of flooding each single compartment and each possible group of two or more adjacent compartments; and
- .2 the probability that the stability after flooding a compartment or a group of two or more adjacent compartments will be sufficient to prevent capsizing or dangerous heeling due to loss of stability or to heeling moments in intermediate or final stages of flooding.



12 This concept allows a rule requirement to be applied by requiring a minimum value of A for a particular ship. This minimum value is referred to as the “required subdivision index”, R, in the present regulations and can be made dependent on ship size, number of passengers or other factors legislators might consider important.

13 Evidence of compliance with the rules then simply becomes:

$$A \geq R$$

As explained above, the attained subdivision index A is determined by a formula for the entire probability as the sum of the products for each compartment or group of compartments of the probability that a space is flooded, multiplied by the probability that the ship will not capsize or sink due to flooding of the considered space. In other words, the general formula for the attained index can be given in the form:

$$A = \sum p_i s_i$$

Subscript “i” represents the damage zone (group of compartments) under consideration within the watertight subdivision of the ship. The subdivision is viewed in the longitudinal direction, starting with the aftmost zone/compartment.

The value of “ $p_i$ ” represents the probability that only the zone “i” under consideration will be flooded, disregarding any horizontal subdivision, but taking transverse subdivision into account. Longitudinal subdivision within the zone will result in additional flooding scenarios, each with their own probability of occurrence.

The value of “ $s_i$ ” represents the probability of survival after flooding the zone “i” under consideration.

14 Although the ideas outlined above are very simple, their practical application in an exact manner would give rise to several difficulties if a mathematically perfect method was to be developed. As pointed out above, an extensive but still incomplete description of the damage will include its longitudinal and vertical location as well as its longitudinal, vertical and transverse extent. Apart from the difficulties in handling such a five-dimensional random variable, it is impossible to determine its probability distribution very accurately with the presently available damage statistics. Similar limitations are true for the variables and physical relationships involved in the calculation of the probability that a ship will not capsize or sink during intermediate stages or in the final stage of flooding.

15 A close approximation of the available statistics would result in extremely numerous and complicated computations. In order to make the concept practicable, extensive simplifications are necessary. Although it is not possible to calculate the exact probability of survival on such a simplified basis, it has still been possible to develop a useful comparative measure of the merits of the longitudinal, transverse and horizontal subdivision of the ship.

**PART B**  
**GUIDANCE ON INDIVIDUAL REGULATIONS**

**Regulation 2 – Definitions**

**Paragraph 1**

Subdivision length ( $L_s$ ) – Different examples of  $L_s$  showing the buoyant hull and the reserve buoyancy are provided in the figures below. The limiting deck for the reserve buoyancy may be partially watertight.

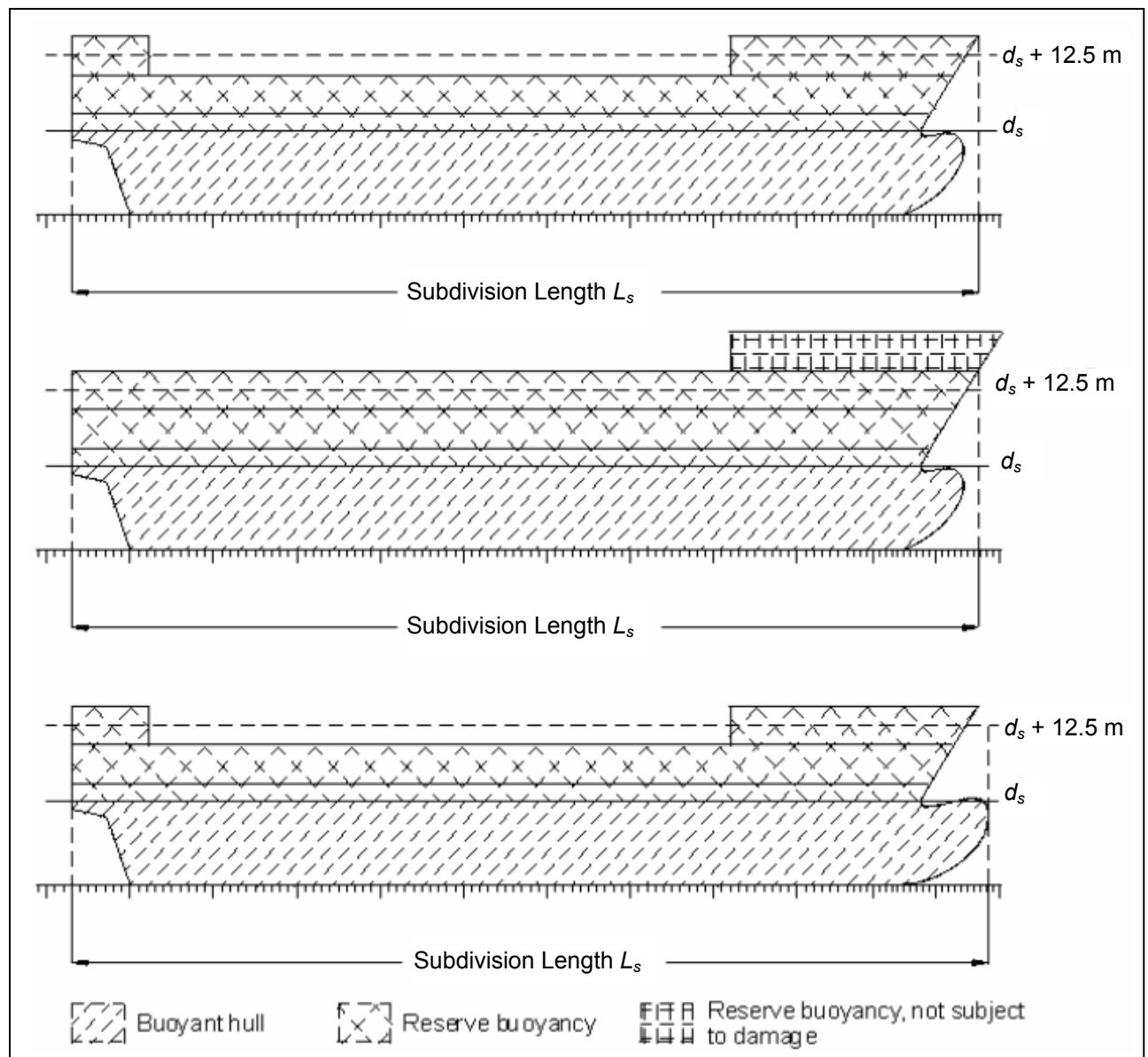

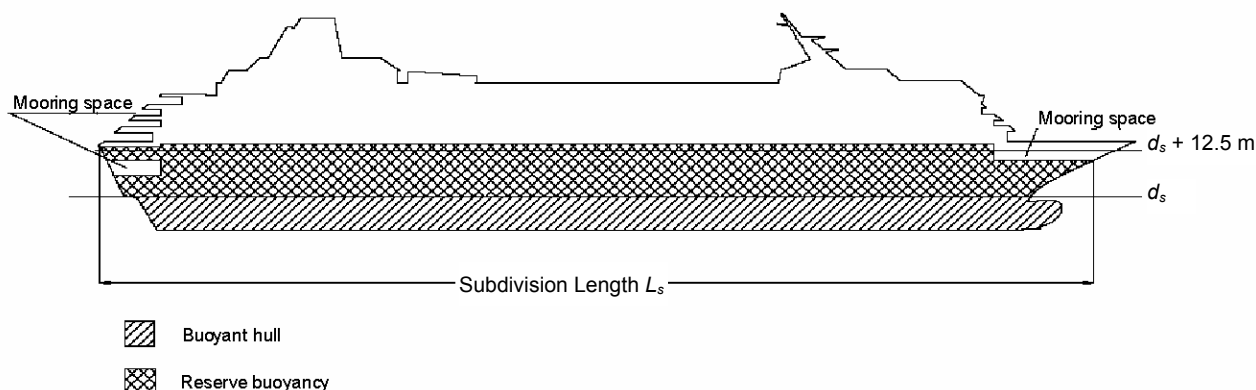

### ***Paragraph 6***

Freeboard deck – See notes under regulation 13-1 for the treatment of a stepped freeboard deck with regard to watertightness and construction requirements.

### ***Paragraph 11***

Light service draught ( $d_l$ ) – The light service draught ( $d_l$ ) represents the lower draught limit of the minimum required  $GM$  curve. It corresponds, in general, to the ballast arrival condition with 10% consumables for cargo ships. For passenger ships it corresponds, in general, to the arrival condition with 10% consumables, a full complement of passengers and crew and their effects, and ballast as necessary for stability and trim. The 10% arrival condition is not necessarily the specific condition that must be used for all ships, but represents in general a suitable lower limit for all loading conditions. This is understood to not include docking conditions or other non-voyage conditions.

### ***Paragraph 19***

Bulkhead deck – See notes under regulation 13 for the treatment of a stepped bulkhead deck with regard to watertightness and construction requirements.

## Regulation 4 – General

### *Paragraph 1*

	For cargo ships complying with damage stability regulations in other IMO instruments
Reg.	Applies
Part B-1	
5	X
5-1	X
Part B-2	
9	X <sup>(1)</sup>
10	X
11	X
12	X
13-1	X
15	X
15-1	X
16	X
16-1	X
Part B-4	
19	X
22	X
24	X
25	X <sup>(2)</sup>

(1) Only applies to ships other than tankers.

(2) Only applies to single hold cargo ships other than bulk carriers.

### *Paragraph 4*

See notes under regulation 7-2, paragraph 2, for information and guidance related to these provisions.

## Regulation 5 – Intact stability information

Reference is made to MSC/Circ.1158 regarding lightweight check.

### Regulation 5-1 – Stability information to be supplied to the master

#### *Paragraphs 3 and 4 (see also regulation 7, paragraph 2)*

In cases where the operational trim range is intended to exceed +/- 0.5% of  $L_s$ , the original  $GM$  limit line is to be designed in the usual manner with the deepest subdivision draught and partial subdivision draught calculated at level trim and actual service trim used for the light service

draught. Then additional sets of *GM* limit lines should be constructed on the basis of the full range of trims ensuring that intervals of 1%  $L_s$  are not exceeded. The sets of *GM* limit lines are combined to give one envelope limiting *GM* curve. The effective trim range of the curve should be clearly stated.

## **Regulation 6 – Required subdivision index *R***

### ***Paragraph 1***

To demonstrate compliance with these provisions, see the guidelines in the appendix regarding the presentation of damage stability calculation results.

## **Regulation 7 – Attained subdivision index *A***

### ***Paragraph 1***

The probability of surviving after collision damage to the ship hull is expressed by the index *A*. Producing an index *A* requires calculation of various damage scenarios defined by the extent of damage and the initial loading conditions of the ship before damage. Three loading conditions should be considered and the result weighted as follows:

$$A = 0.4A_s + 0.4A_p + 0.2A_l$$

where the indices *s*, *p* and *l* represent the three loading conditions and the factor to be multiplied to the index indicates how the index *A* from each loading condition is weighted.

The method of calculating the *A* for a loading condition is expressed by the formula:

$$A_c = \sum_{i=1}^{i=t} p_i [v_i s_i]$$

The index *c* represents one of the three loading conditions, index *i* represents each investigated damage or group of damages and *t* is the number of damages to be investigated to calculate  $A_c$  for the particular loading condition.

To obtain a maximum index *A* for a given subdivision, *t* has to be equal to *T*, the total number of damages.

In practice the damage combinations to be considered are limited either by significantly reduced survivability possibility (i.e. flooding of substantially larger volumes) or by exceeding the maximum possible damage length.

The index *A* is divided into part factors as follows:

- $p_i$  The *p* factor is solely dependent on the geometry of the watertight arrangement of the ship.
- $v_i$  The *v* factor is dependent on the geometry of the watertight arrangement (decks) of the ship and the draught of the initial loading condition. It represents the probability that the spaces above the horizontal subdivision will not be flooded.

$s_i$  The  $s$  factor is dependent on the calculated stability of the ship after damage in a specific initial condition.

Three initial loading conditions should be used for calculating the index  $A$ . The loading conditions are defined by their mean draught  $d$ , trim and  $GM$ .

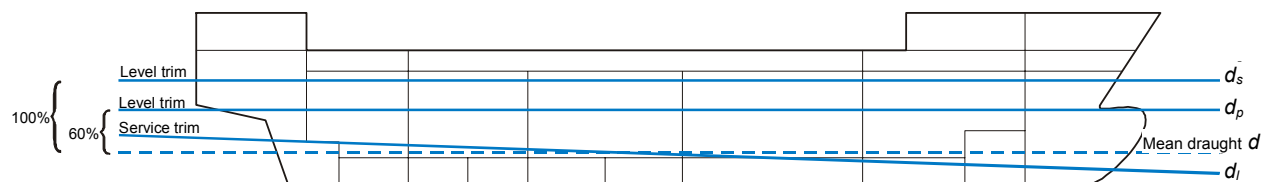

The mean draught and trim are illustrated in the figure above.

The  $GM$  values for the three loading conditions could, as a first attempt, be taken from the intact stability  $GM$  limit curve. If the required index  $R$  is not obtained, the  $GM$  values may be increased, implying that the intact loading conditions from the intact stability book must now meet the  $GM$  limit curve from the damage stability calculations derived by linear interpolation between the three  $GM$ 's.

### **Paragraph 2**

The calculations for differing trim should be carried out with the same initial trim for the partial and deepest subdivision draughts. For the light service draught, the actual service trim should be used (refer to the notes to regulation 2, paragraph 11).

Each combination of the index within the formula given in regulation 7.1 should not be less than the requirement given in regulation 6.2. Each partial index  $A$  should comply with the requirements of regulation 6.1.

Example:

Based on the  $GM$  limiting curves obtained from damage stability calculations of each trim, an envelope curve covering all calculated trim values should be developed.

Calculations covering different trim values should be carried out in steps not exceeding 1% of  $L_s$ . The whole range including intermediate trims should be covered by the damage stability calculations. Refer to the example showing an envelope curve obtained from calculations of 0 trim and 1% of  $L_s$ .

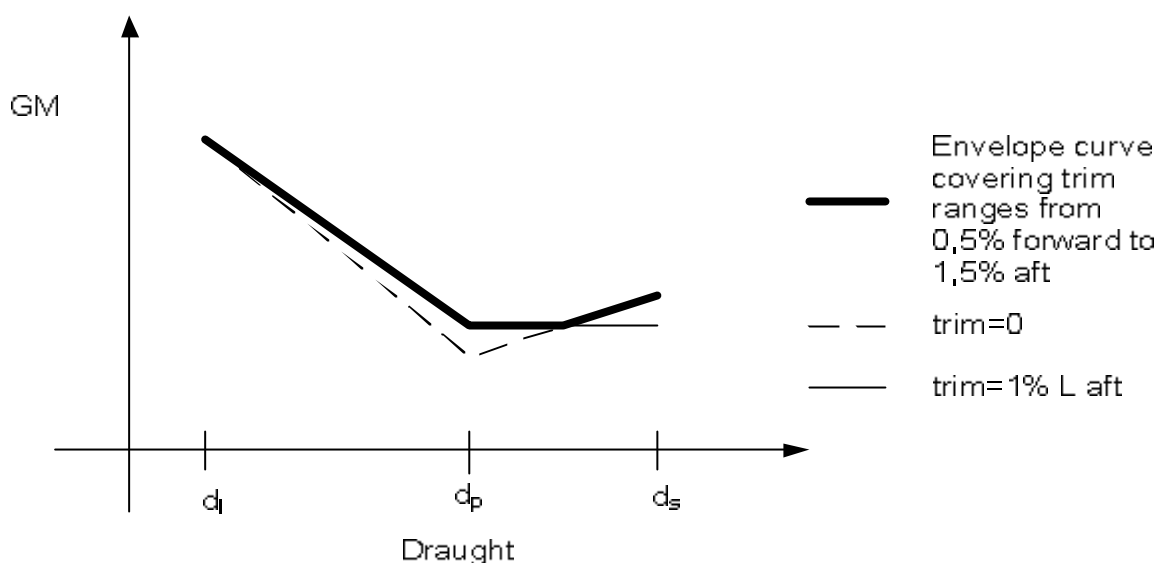

### **Paragraph 5**

In the forward and aft ends of the ship where the sectional breadth is less than the ship's breadth  $B$ , transverse damage penetration can extend beyond the centreline bulkhead. This application of the transverse extent of damage is consistent with the methodology to account for the localized statistics which are normalized on the greatest moulded breadth  $B$  rather than the partial breadth.

Where corrugated bulkheads are fitted, they may be treated as ordinary stiffened bulkheads as long as the corrugation is of the same order as the stiffening structure.

Pipes and valves directly adjacent to the bulkhead can be considered to be a part of the bulkhead. The same applies for small recesses, drain wells, etc.

### **Regulation 7-1 – Calculation of the factor $p_i$**

#### **General**

The definitions below are intended to be used for the application of part B-1 only.

In regulation 7-1, the words "compartment" and "group of compartments" should be understood to mean "zone" and "adjacent zones".

Zone – a longitudinal interval of the ship within the subdivision length.

Room – a part of the ship, limited by bulkheads and decks, having a specific permeability.

Space – a combination of rooms.

Compartment – an onboard space within watertight boundaries.

Damage – the three dimensional extent of the breach in the ship.

For the calculation of  $p$ ,  $v$ ,  $r$  and  $b$  only the damage should be considered, for the calculation of the  $s$ -value the flooded space has to be considered. The figures below illustrate the difference.

Damage shown as the bold square:

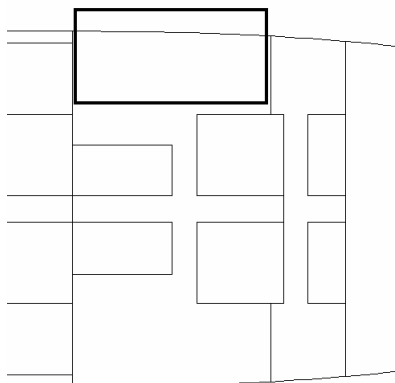

Flooded space shown below:

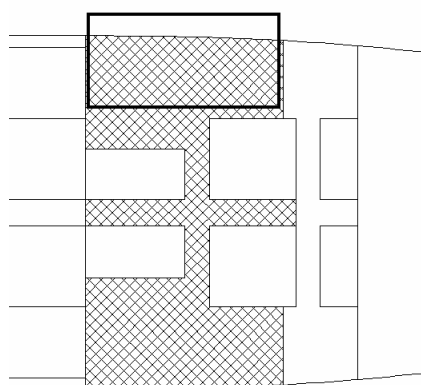

### ***Paragraph 1.1***

The coefficients  $b_{11}$ ,  $b_{12}$ ,  $b_{21}$  and  $b_{22}$  are coefficients in the bi-linear probability density function on normalized damage length ( $J$ ).  $b_{12}$  is dependent on whether or not  $L_s \leq L^*$ , the other coefficients are valid irrespective of  $L_s$ .

#### *Longitudinal subdivision*

In order to prepare for the calculation of index  $A$ , the ship's subdivision length  $L_s$  is divided into a fixed discrete number of damage zones. These damage zones will determine the damage stability investigation in the way of specific damages to be calculated.

There are no rules for the subdividing, except that the length  $L_s$  defines the extremes for the actual hull. However, it is important to consider a strategy carefully to obtain a good result (that is a large attained index  $A$ ). All zones and combination of adjacent zones may contribute to the index  $A$ .



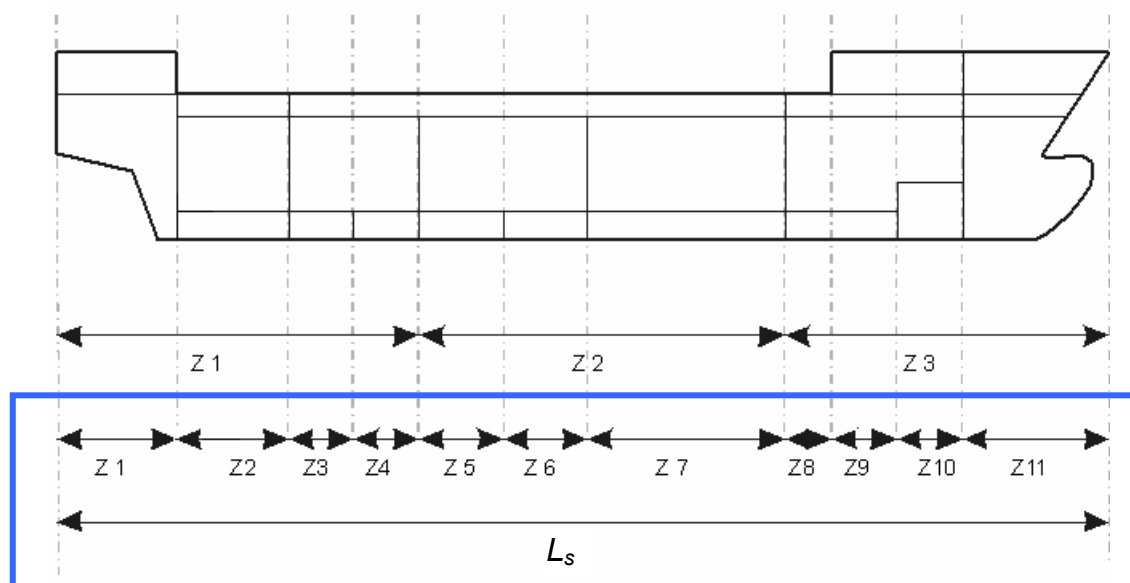

The figure above shows different longitudinal divisions of the length  $L_s$ .

The first example is a very rough division into three zones of approximately the same size with limits where transverse subdivision is established. The probability that the ship will survive a damage in one of the three zones is expected to be low ( $s$ -factor = 0) and therefore the total attained index  $A$  will be lost.

In the second example the zones have been placed in accordance with the watertight arrangement, including minor subdivision (as in double bottom, etc.). The chances of getting good  $s$ -factors in this case should be good.

Where transverse corrugated bulkheads are fitted, they may be treated as equivalent plane bulkheads, provided the corrugation is of the same order as the stiffening structure.

The triangle in the figure below illustrates the possible single and multiple zone damages in a ship with a watertight arrangement suitable for a seven-zone division. The triangles at the bottom line indicate single zone damages and the parallelograms indicate adjacent zones damages.

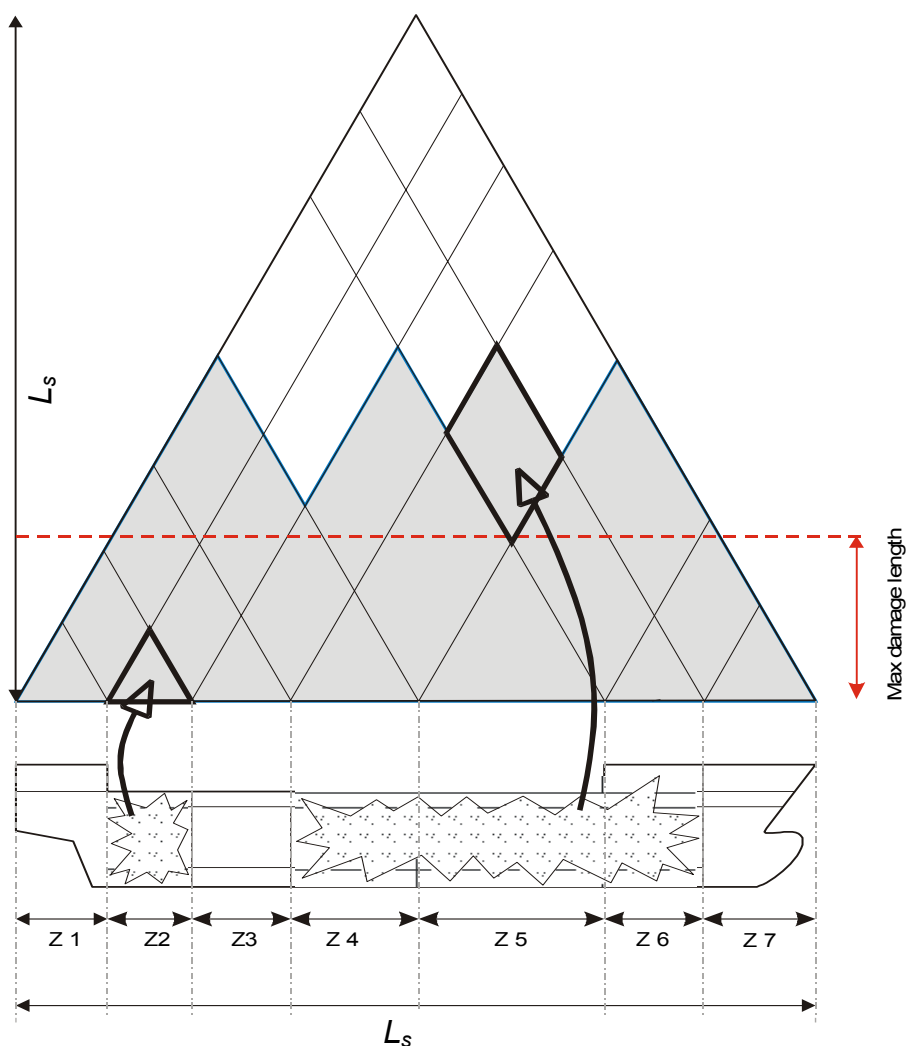

Figure illustrates the possible single and multiple zone damages in a ship.

As an example, the triangle illustrates a damage opening the rooms in zone 2 to the sea and the parallelogram illustrates a damage where rooms in the zones 4, 5 and 6 are flooded simultaneously.

The shaded area illustrates the effect of the maximum absolute damage length. The  $p$ -factor for a combination of three or more adjacent zones equals zero if the length of the combined adjacent damage zones minus the length of the foremost and the aft most damage zones in the combined damage zone is greater than the maximum damage length. Having this in mind when subdividing  $L_s$  could limit the number of zones defined to optimize the attained index  $A$ .

As the  $p$ -factor is related to the watertight arrangement by the longitudinal limits of damage zones and the transverse distance from the ship side to any longitudinal barrier in the zone, the following indices are introduced:

- $j$ : the damage zone number starting with no.1 at the stern;
- $n$ : the number of adjacent damage zones in question where  $j$  is the aft zone;
- $k$ : the number of a particular longitudinal bulkhead as a barrier for transverse penetration in a damage zone counted from shell towards the centreline. The shell has no.0;
- $K$ : total number of transverse limits;
- $P_{j,n,k}$ : the  $p$ -factor for a damage in zone  $j$  and next  $(n-1)$  zones forward of  $j$  damaged to the longitudinal bulkhead  $k$ .

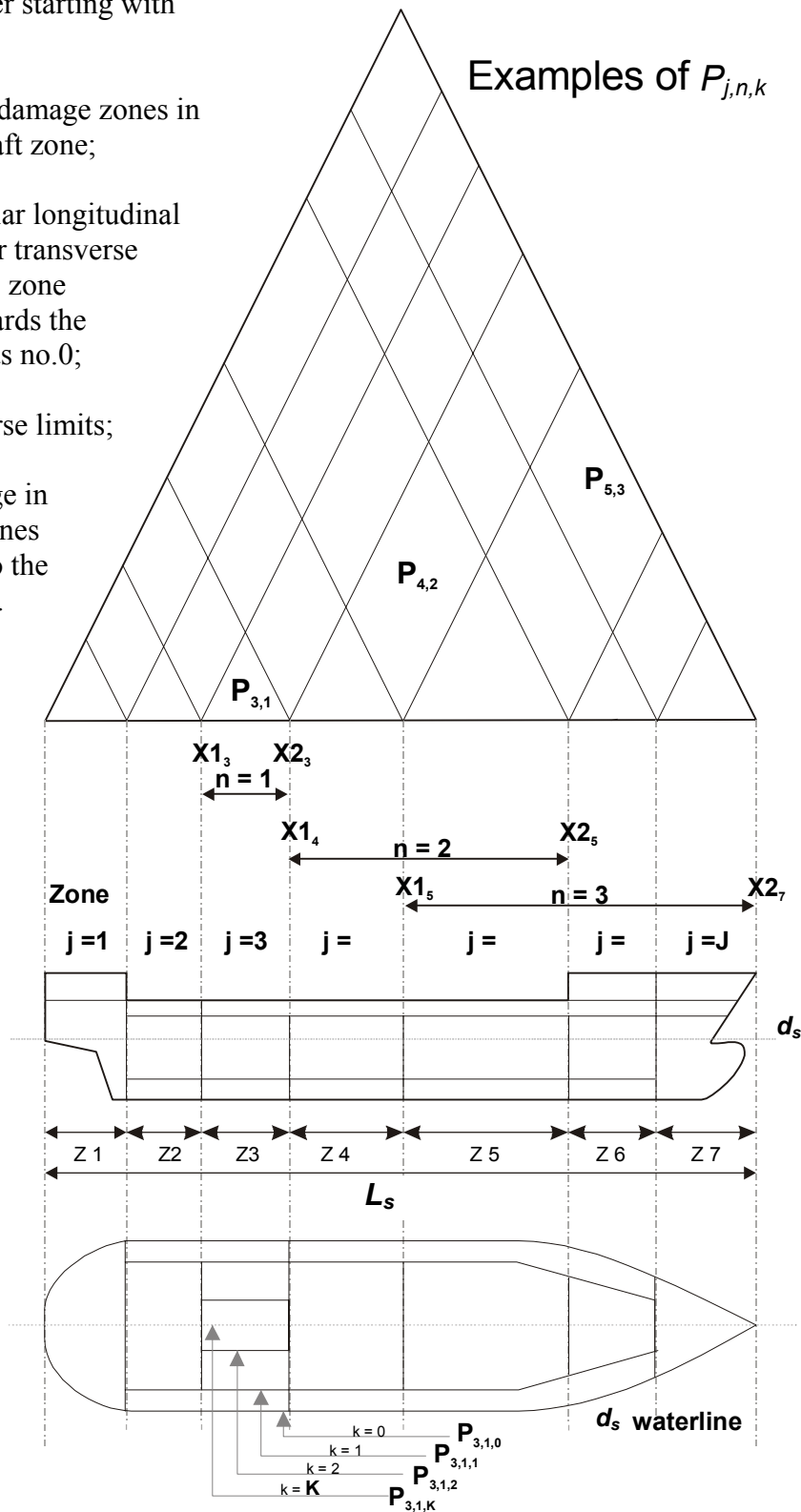

*Pure transverse subdivision*

Single damage zone, pure transverse subdivision:

$$p_{j,1} = p(x_{1j}, x_{2j})$$

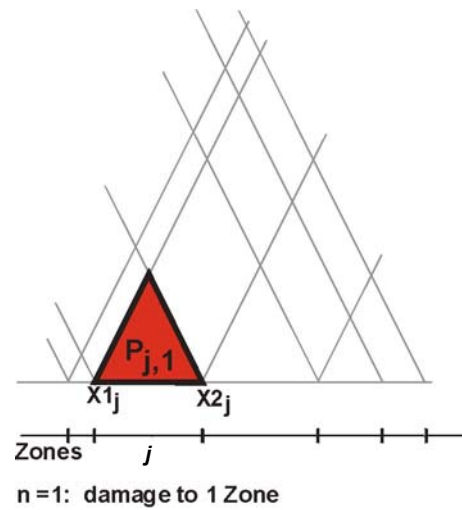

Two adjacent zones, pure transverse subdivision:

$$p_{j,2} = p(x_{1j}, x_{2j+1}) - p(x_{1j}, x_{2j}) - p(x_{1j+1}, x_{2j+1})$$

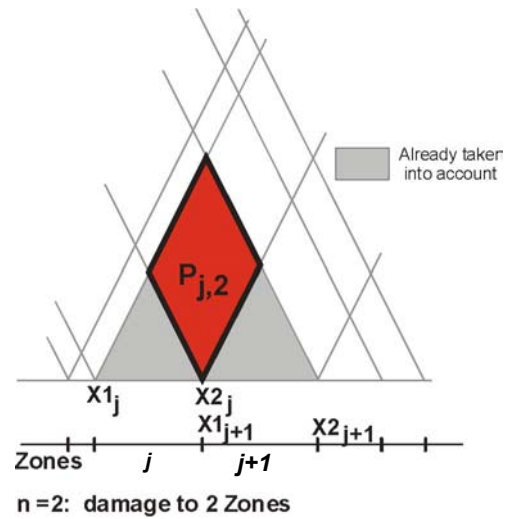

Three or more adjacent zones, pure transverse subdivision:

$$p_{j,n} = p(x_{1j}, x_{2j+n-1}) - p(x_{1j}, x_{2j+n-2}) - p(x_{1j+1}, x_{2j+n-1}) + p(x_{1j+1}, x_{2j+n-2})$$

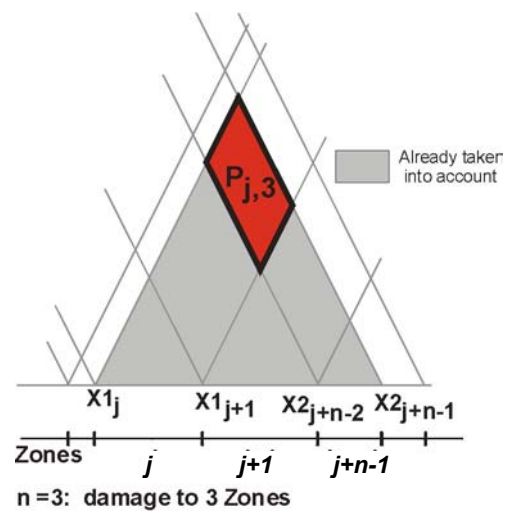

**Paragraph 1.2**

*Transverse subdivision in a damage zone*

Damage to the hull in a specific damage zone may just penetrate the ship's watertight hull or penetrate further towards the centreline. To describe the probability of penetrating only a wing compartment, a probability factor  $r$  is used, based mainly on the penetration depth  $b$ . The value of  $r$  is equal to 1, if the penetration depth is  $B/2$  where  $B$  is the maximum breadth of the ship at the deepest subdivision draught  $d_s$ , and  $r = 0$  if  $b = 0$ .

The penetration depth  $b$  is measured at level deepest subdivision draught  $d_s$  as a transverse distance from the ship side right-angled to the centreline to a longitudinal barrier.

Where the actual watertight bulkhead is not a plane parallel to the shell,  $b$  should be determined by means of an assumed line, dividing the zone to the shell in a relationship  $b_1/b_2$  with  $1/2 \leq b_1/b_2 \leq 2$ .

Examples of such assumed division lines are illustrated in the figure below. Each sketch represents a single damage zone at a water line plane level  $d_s$  and the longitudinal bulkhead represents the outermost bulkhead position below  $d_s + 12.5$  m.

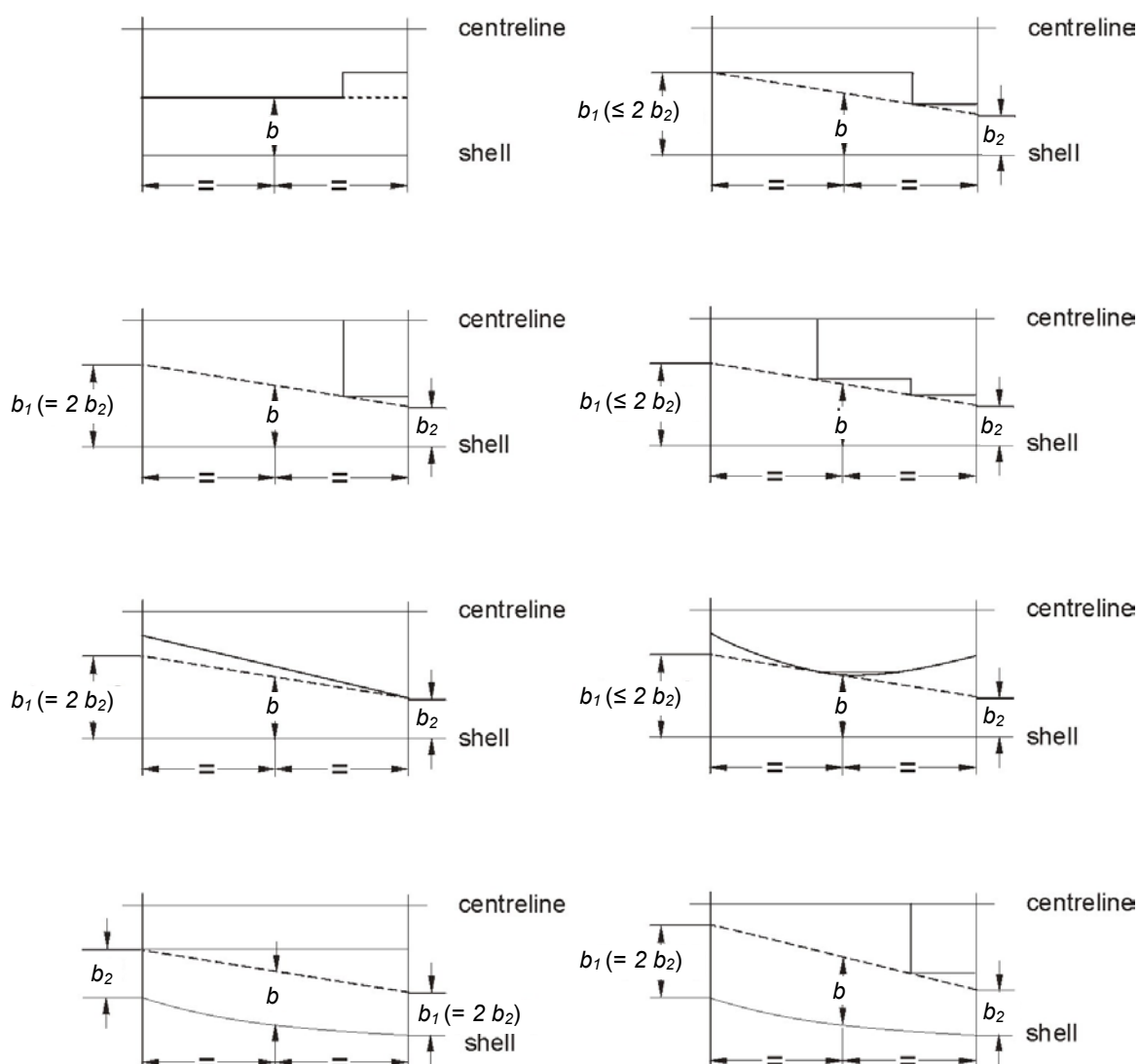

In calculating  $r$ -values for a group of two or more adjacent compartments, the  $b$ -value is common for all compartments in that group, and equal to the smallest  $b$ -value in that group:

$$b = \min \{b_1, b_2, \dots, b_n\}$$

where:  $n =$  number of wing compartments in that group;  
 $b_1, b_2, \dots, b_n =$  mean values of  $b$  for individual wing compartments contained in the group.

### Accumulating $p$

The accumulated value of  $p$  for one zone or a group of adjacent zones is determined by:

$$p_{j,n} = \sum_{k=1}^{k=K_{j,n}} p_{j,n,k}$$

where  $K_{j,n} = \sum_j^{j+n-1} K_j$  the total number of  $b_k$ 's for the adjacent zones in question.

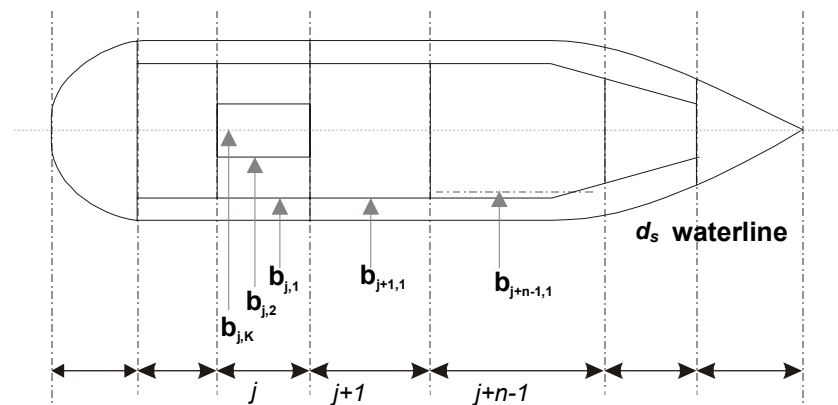

The figure above illustrates  $b$ 's for adjacent zones. The zone  $j$  has two penetration limits and one to the centre, the zone  $j+1$  has one  $b$  and the zone  $j+n-1$  has one value for  $b$ . The multiple zones will have  $(2+1+1)$  four values of  $b$ , and sorted in increasing order they are:

$$(b_{j,1}; b_{j+1,1}; b_{j+n-1,1}; b_{j,2}; b_K)$$

Because of the expression for  $r(x1, x2, b)$  only one  $b_K$  is to be considered. To minimize the number of calculations,  $b$ 's of the same value may be deleted.

As  $b_{j,1} = b_{j+1,1}$  the final  $b$ 's will be  $(b_{j,1}; b_{j+n-1,1}; b_{j,2}; b_K)$

The total accumulated  $p$

$$p = \sum_{j=1}^{j=T} p_{j,n}$$

where  $T$  is the total number of damages.

*Examples of multiple zones having a different b*

Examples of combined damage zones and damage definitions are given in the figures below. Rooms are identified by R10, R12, etc.

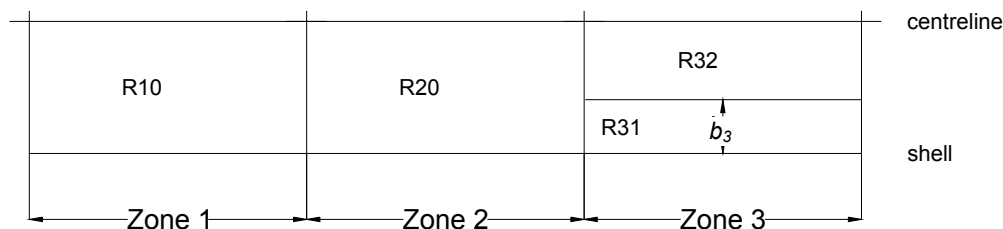

Figure: Combined damage of zones 1 + 2 + 3 includes a limited penetration to  $b_3$ , taken into account generating two damages:

- 1) to  $b_3$  with R10, R20 and R31 damaged
- 2) to  $B/2$  with R10, R20, R31 and R32 damaged

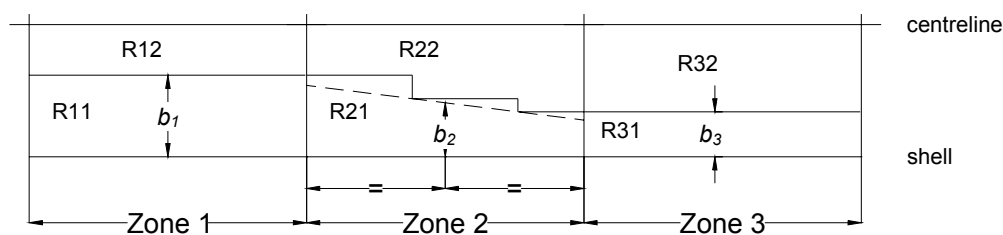

Figure: Combined damage of zones 1 + 2 + 3 includes 3 different limited damage penetrations generating four damages:

- 1) to  $b_3$  with R11, R21 and R31 damaged
- 2) to  $b_2$  with R11, R21, R31 and R32 damaged
- 3) to  $b_1$  with R11, R21, R31, R32, and R22 damaged
- 4) to  $B/2$  with R11, R21, R31, R32, R22 and R12 damaged

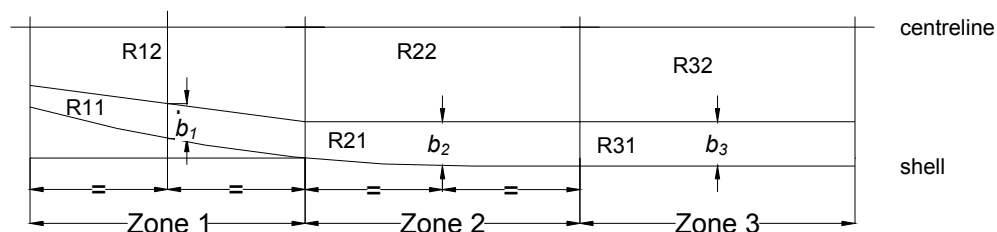
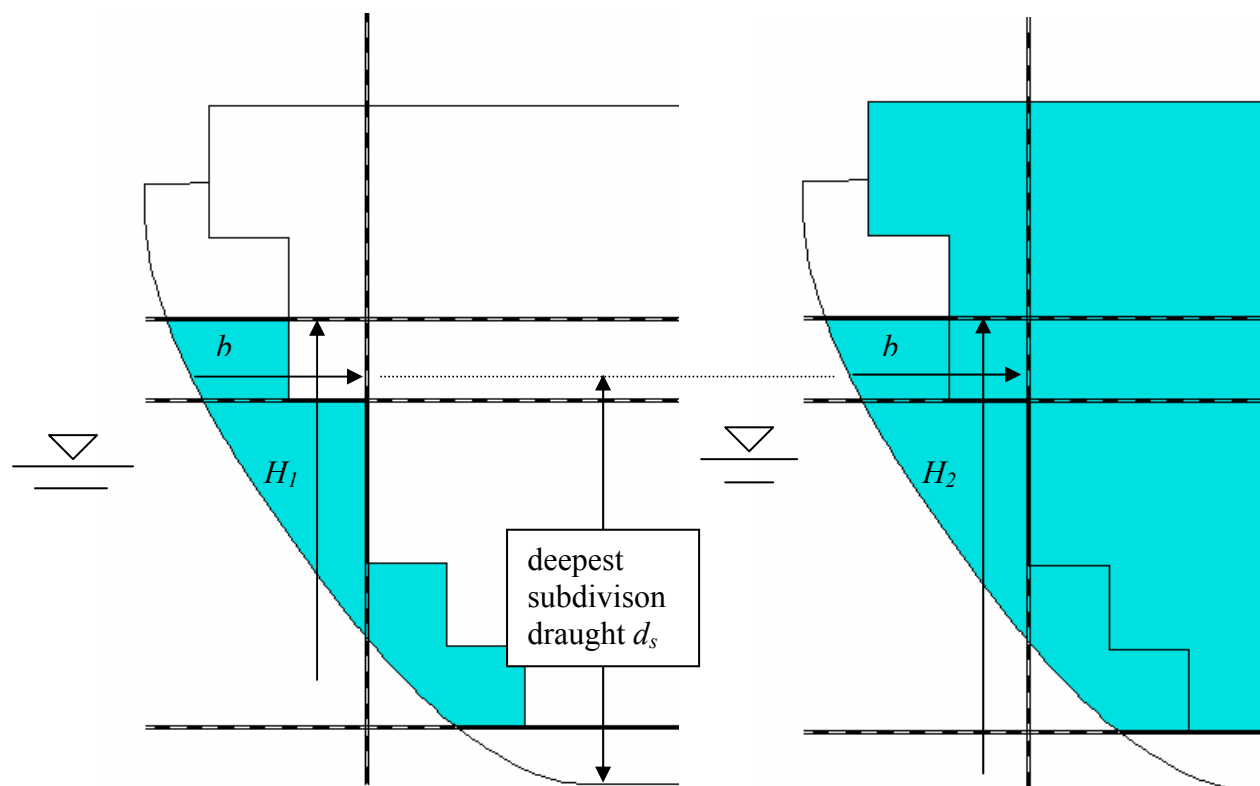

Figure: Combined damage of zone 1 + 2 + 3 including 2 different limited damage penetrations ( $b_1 < b_2 = b_3$ ) generating three damages:

- 1) to  $b_1$  with R11, R21 and R31 damaged
- 2) to  $b_2$  with R11, R21, R31 and R12, damaged
- 3) to  $B/2$  with R11, R21, R31, R12, and R22, R32 damage

A damage having a horizontal extension  $b$  and a vertical extension  $H_2$  leads to a flooding of both wing compartment and hold; for  $b$  and  $H_1$  only the wing compartment. The figure illustrates a partial subdivision draught  $d_p$  damage.



The same is valid if  $b$ -values are calculated for arrangements with sloped walls.

## Regulation 7-2 – Calculation of the factor $s_i$

### General

Initial condition – an intact loading condition to be considered in the damage analysis described by the mean draught, vertical centre of gravity and the trim. Or alternative parameters from where the same may be determined (ex. displacement,  $GM$  and trim). There are three initial conditions corresponding to the three draughts  $d_s$ ,  $d_p$  and  $d_l$ .

Immersion limits – immersion limits are an array of points that are not to be immersed at various stages of flooding as indicated in paragraphs 5.2 and 5.3.

Openings – all openings need to be defined: both weathertight and unprotected. Openings are the most critical factor to preventing an inaccurate index  $A$ . If the final waterline immerses the lower edge of any opening through which progressive flooding takes place, the factor “ $s$ ” may be recalculated taking such flooding into account. However, in this case the  $s$  value should also be calculated without taking into account progressive flooding and corresponding opening. The smallest  $s$  value should be retained for the contribution to the attained index.



## ***Paragraph 2***

### *Intermediate stages of flooding*

The case of instantaneous flooding in unrestricted spaces in way of the damage zone does not require intermediate stage flooding calculations. Where intermediate stages of flooding calculations are necessary in connection with progressive flooding, they should reflect the sequence of filling as well as filling level phases. Calculations for intermediate stages of flooding should be performed whenever equalization is not instantaneous, i.e. equalization is of a duration greater than 60 s. Such calculations consider the progress through one or more floodable (non-watertight) spaces. Bulkheads surrounding refrigerated spaces, incinerator rooms and longitudinal bulkheads fitted with non-watertight doors are typical examples of structures that may significantly slow down the equalization of main compartments.

### *Flooding boundaries*

If a compartment contains decks, inner bulkheads, structural elements and doors of sufficient tightness and strength to seriously restrict the flow of water, for intermediate stage flooding calculation purposes it should be divided into corresponding non-watertight spaces. It is assumed that the non-watertight divisions considered in the calculations are limited to “A” class fire-rated bulkheads and do not apply to “B” class fire-rated bulkheads normally used in accommodation areas (e.g. cabins and corridors). This guidance also relates to regulation 4, paragraph 4.

### *Sequential flooding computation*

For each damage scenario, the damage extent and location determine the initial stage of flooding. Calculations should be performed in stages, each stage comprising of at least two intermediate filling phases in addition to the full phase per flooded space. Unrestricted spaces in way of damage should be considered as flooded immediately. Every subsequent stage involves all connected spaces being flooded simultaneously until an impermeable boundary or final equilibrium is reached. If due to the configuration of the subdivision in the ship it is expected that other intermediate stages of flooding are more onerous, then those should be investigated.

### *Cross flooding/equalization*

In general, cross flooding is meant as a flooding of an undamaged space on the other side of the ship to reduce the heel in the final equilibrium condition.

The cross-flooding time should be calculated in accordance with resolution A.266(VIII). If complete fluid equalization occurs in 60 s or less, it should be treated as instantaneous and no further calculations need to be carried out. Only passive open cross-flooding arrangements without valves should be considered effective for instantaneous flooding cases.

If complete fluid equalization can be finalized in 10 min or less, the assessment of survivability can be carried out for passenger ships as the smallest values of  $S_{intermediate,i}$  or  $S_{final}$ .

In case the equalization time is longer than 10 min,  $S_{final}$  is calculated for the floating position achieved after 10 min of equalization. This floating position is computed by calculating the amount of flood water according to resolution A.266(VIII) using interpolation, where the equalization time is set to 10 min, i.e. the interpolation of the flood water volume is made between the case before equalization ( $T = 0$ ) and the total calculated equalization time.

In any cases where complete fluid equalization exceeds 10 min, the value of  $s_{final}$  used in the formula in paragraph 1.1 should be the minimum of  $s_{final, i}$  at 10 min or at final equalization.

#### ***Paragraph 4***

The displacement is the intact displacement at the subdivision draught in question ( $d_s$ ,  $d_p$  and  $d_l$ ).

#### ***Paragraph 4.1.1***

The beam  $B$  used in this paragraph means breadth as defined in regulation 2.8.

#### ***Paragraph 4.1.2***

The parameter  $A$  (projected lateral area) used in this paragraph does not refer to the attained subdivision index.

#### ***Paragraph 5***

In cargo ships where cross flooding devices are fitted, the safety of the ship must be maintained in all stages of flooding. The Administration may request for this to be demonstrated. Cross-flooding equipment, if installed, should have the capacity to ensure that the equalization takes place within 10 min.

#### ***Paragraph 5.2.1***

##### *Unprotected openings*

The flooding angle will be limited by immersion of such an opening. It is not necessary to define a criterion for non-immersion of unprotected openings at equilibrium, because if it is immersed, the range of positive  $GZ$  limited to flooding angle will be zero so “ $s$ ” will be equal to zero.

An unprotected opening connects two rooms or one room and the outside. An unprotected opening will not be taken into account if the two connected rooms are flooded or none of these rooms are flooded. If the opening is connected to the outside, it will not be taken into account if the connected compartment is flooded. An unprotected opening does not need to be taken into account if it connects a flooded room or the outside to an undamaged room, if this room will be considered as flooded in a subsequent stage.

##### *Openings fitted with a weathertight means of closing (“weathertight openings”)*

The survival “ $s$ ” factor will be “0” if any such point is submerged at a stage which is considered as “final”. Such points may be submerged during a stage or phase which is considered as “intermediate”, or within the range beyond equilibrium.

If an opening fitted with a weathertight means of closure is submerged at equilibrium during a stage considered as intermediate, it should be demonstrated that this weathertight means of closure can sustain the corresponding head of water and that the leakage rate is negligible.

These points are also defined as connecting two rooms or one room and the outside, and the same principle as for unprotected openings is applied to take them into account or not. If several stages have to be considered as “final”, a “weathertight opening” does not need to be taken into

account if it connects a flooded room or the outside to an undamaged room if this room will be considered as flooded in a successive “final” stage.

**Paragraph 5.2.2**

Horizontal evacuation routes on the bulkhead deck include only escape routes (designated as category 2 stairway spaces according to SOLAS regulation II-2/9.2.2.3 or as category 4 stairway spaces according to SOLAS regulation II-2/9.2.2.4 for passenger ships carrying not more than 36 passengers) used for the evacuation of undamaged spaces. Horizontal evacuation routes do not include corridors within the damaged space. No part of a horizontal evacuation route should be immersed.

The provisions for escape in SOLAS chapter II-2 may allow more than one watertight compartment below the bulkhead deck to be served by a common stairway within the same main vertical zone (MVZ). Partial immersion of the bulkhead deck may be accepted at final equilibrium. The new provision is intended to ensure that evacuation along the bulkhead deck to the vertical escapes will not be impeded by water on that deck. A “horizontal evacuation route” in the context of this regulation means a route on the bulkhead deck connecting spaces located on and under this deck with the vertical escapes from the bulkhead deck required for compliance with SOLAS chapter II-2.

**Paragraph 5.3.1**

The purpose of this paragraph is to provide an incentive to ensure that evacuation through a vertical escape will not be obstructed by water from above. The paragraph is intended for smaller emergency escapes, typically hatches, where fitting of a watertight or weathertight means of closure would otherwise exclude them from being considered as flooding points.

Since the probabilistic regulations do not require that the watertight bulkheads be carried continuously up to the bulkhead deck, care should be taken to ensure that evacuation from intact spaces through flooded spaces below the bulkhead deck will remain possible, for instance by means of a watertight trunk.

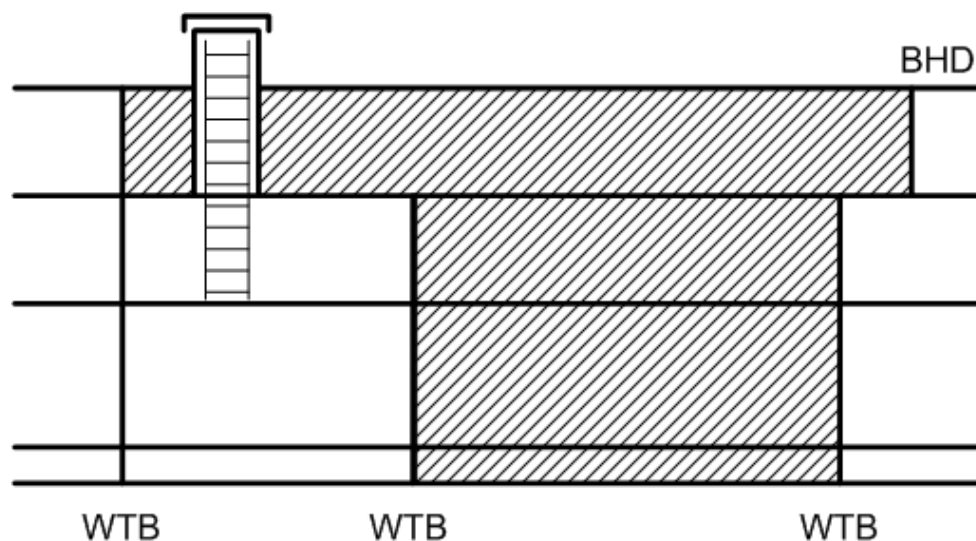

**Paragraph 6**

The sketches in the figure illustrate the connection between position of watertight decks in the reserve buoyancy area and the use of factor  $v$  for damages below these decks.

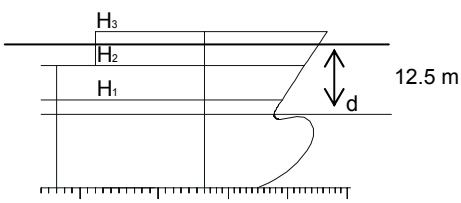
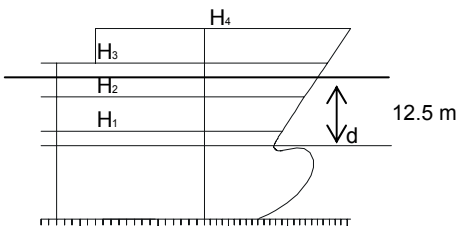
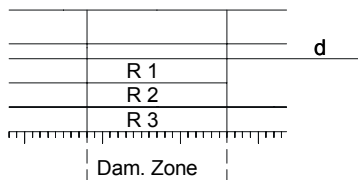
<p style="text-align: center;">Above the waterline</p>   <p style="text-align: center;">Below the waterline</p> 	<p>In this example, there are 3 horizontal subdivisions to be taken into account as the vertical extent of damage.</p> <p>The example shows the maximum possible vertical extent of damage <math>d + 12.5</math> m is positioned between <math>H_2</math> and <math>H_3</math>. <math>H_1</math> with factor <math>v_1</math>, <math>H_2</math> with factor <math>v_2 &gt; v_1</math> but <math>v_2 &lt; 1</math> and <math>H_3</math> with factor <math>v_3 = 1</math>.</p> <p>The factors <math>v_1</math> and <math>v_2</math> are the same as above. The reserve buoyancy above <math>H_3</math> is to be taken undamaged in all damage cases.</p> <p>The combination of damages into the rooms R1, R2 and R3 positioned below the initial water line must be chosen so that the damage with the lowest <math>s</math>-factor is taken into account. That often results in the definition of alternative damages to be calculated and compared. If the deck taken as lower limit of damage is not watertight, down flooding should be considered.</p>
--	---

**Paragraph 6.1**

The parameters  $x_1$  and  $x_2$  are the same as parameters  $x1$  and  $x2$  used in regulation 7-1.

**Regulation 7-3 – Permeability**

**Paragraph 2**

The following additional cargo permeabilities may be used:

Spaces	Permeability at draught $d_s$	Permeability at draught $d_p$	Permeability at draught $d_l$
Timber cargo in holds	0.35	0.70	0.95
Wood chip cargo	0.60	0.70	0.95

### ***Paragraph 3***

Concerning the use of other figures for permeability “if substantiated by calculations”, such permeabilities should reflect the general conditions of the ship throughout its service life rather than specific loading conditions.

This paragraph allows for the recalculation of permeabilities. This should only be considered in cases where it is evident that there is a major discrepancy between the values shown in the regulation and the real values. It is not designed for improving the attained value of a deficient ship of regular type by the modification of chosen spaces in the ship that are known to provide significantly onerous results. All proposals should be considered on a case-by-case basis by the Administration and must be justified with adequate calculations and arguments.

### **Regulation 8 – Special requirements concerning passenger ship stability**

#### ***Paragraphs 3.2 to 3.5***

The number of persons carried, which is specified in these paragraphs, equals the total number of persons on board (and not  $N = N_1 + 2 N_2$  as defined in regulation 6).

### **Regulation 9 – Double bottoms in passenger ships and cargo ships other than tankers**

#### ***Paragraph 2***

If an inner bottom is located higher than the partial subdivision draught  $d_p$ , this should be considered an unusual arrangement in accordance with paragraph 7.

#### ***Paragraph 9***

For the purpose of identifying “large lower holds”, horizontal surfaces having a continuous deck area greater than approximately 30% in comparison with the waterplane area at subdivision draught should be taken located anywhere in the affected area of the ship. For the alternative bottom damage calculation, a vertical extent of  $B/10$  or 3 m, whichever is less, should be assumed.

The increased minimum double bottom height of not more than  $B/10$  or 3 m, whichever is less, for passenger ships with large lower holds, is applicable to holds in direct contact with the double bottom. Typical arrangements of ro-ro passenger ships may include a large lower hold with additional tanks between the double bottom and the lower hold, as shown in the figure below. In such cases, the vertical position of the double bottom required to be  $B/10$  or 3 m, whichever is less, should be applied to the lower hold deck, maintaining the required double bottom height of  $B/20$  or 2 m, whichever is less (but not less than 760 mm).

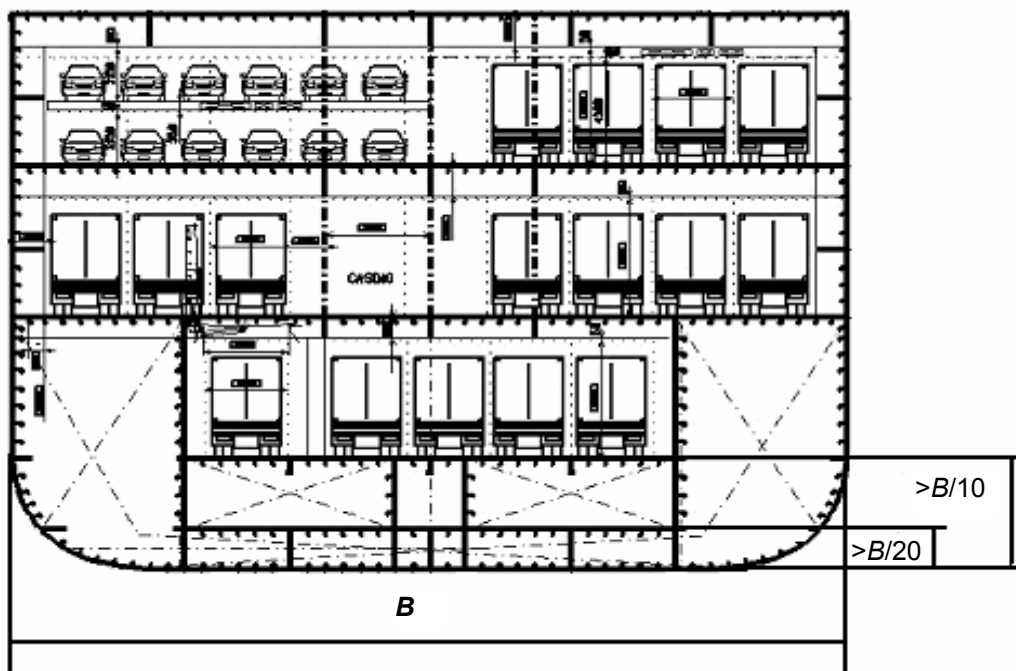

Typical arrangement of a modern ro-ro passenger ferry

## Regulation 10 – Construction of watertight bulkheads

### *Paragraph 1*

For the treatment of steps in the bulkhead deck of passenger ships see notes under regulation 13. For the treatment of steps in the freeboard deck of cargo ships see notes under regulation 13-1.

## Regulation 12 – Peak and machinery space bulkheads, shaft tunnels, etc.

Reference is made to MSC.1/Circ.1211 concerning interpretations regarding bow doors and the extension of the collision bulkhead.

## Regulation 13 – Openings in watertight bulkheads below the bulkhead deck in passenger ships

### *General – Steps in the bulkhead deck*

If the transverse watertight bulkheads in a region of the ship are carried to a higher deck which forms a vertical step in the bulkhead deck, openings located in the bulkhead at the step may be considered as being located above the bulkhead deck. Such openings should then comply with regulation 17 and should be taken into account when applying regulation 7-2.

All openings in the shell plating below the upper deck throughout that region of the ship should be treated as being below the bulkhead deck and the provisions of regulation 15 should be applied. See figure below.

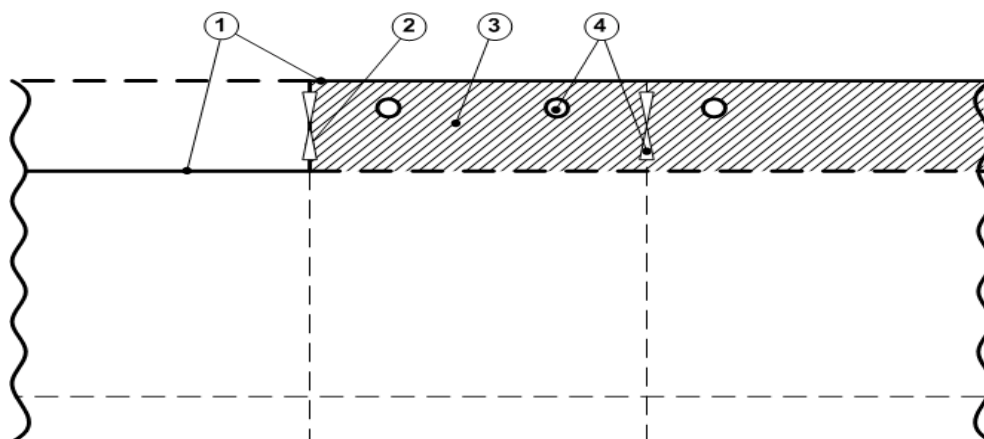

- |                 |   |
|-----------------|---|
| 1 Bulkhead deck | 2 Considered as located above the bulkhead deck |
| 3 Ship's side   | 4 Considered as located below the bulkhead deck |

### ***Paragraph 7.6***

The IEC standard referenced in the footnote (IEC publication 529, 1976) has been replaced by the newer standard IEC 60529:2003.

### **Regulation 13-1 – Openings in watertight bulkheads and internal decks in cargo ships**

#### ***Paragraph 1***

If the transverse watertight bulkheads in a region of the ship are carried to a higher deck than in the remainder of the ship, openings located in the bulkhead at the step may be considered as being located above the freeboard deck.

All openings in the shell plating below the upper deck throughout that region of the ship should be treated as being below the freeboard deck, similar to the bulkhead deck for passenger ships (see figure above), and the provisions of regulation 15 should be applied.

### **Regulation 15 – Openings in the shell plating below the bulkhead deck of passenger ships and the freeboard deck of cargo ships**

#### ***General – Steps in the bulkhead deck and freeboard deck***

For the treatment of steps in the bulkhead deck of passenger ships see notes under regulation 13. For the treatment of steps in the freeboard deck of cargo ships see notes under regulation 13-1.

### **Regulation 15-1 – External openings in cargo ships**

#### ***Paragraph 1***

With regard to air-pipe closing devices, they should be considered weathertight closing devices (not watertight). This is consistent with their treatment in regulation 7-2.5.2.1. However, in the context of regulation 15-1, “external openings” are not intended to include air-pipe openings.

## **Regulation 16 – Construction and initial tests of watertight doors, sidescuttles, etc.**

### ***Paragraph 2***

Watertight doors should be tested by water pressure to a head of water measured from the lower edge of the door opening to the bulkhead deck or the freeboard deck, or to the most unfavourable final or intermediate waterplane during flooding, whichever is greater.

Large doors, hatches or ramps on passenger and cargo ships, of a design and size that would make pressure testing impracticable, may be exempted from regulation 16.2, provided it is demonstrated by calculations that the doors, hatches or ramps maintain watertightness at design pressure with a proper margin of resistance. Where such doors utilize gasket seals, a prototype pressure test to confirm that the compression of the gasket material is capable of accommodating any deflection, revealed by the structural analysis, should be carried out. After installation every such door, hatch or ramp should be tested by means of a hose test or equivalent.

*Note:* See notes under regulation 13 for additional information regarding the treatment of steps in the bulkhead deck of passenger ships. See notes under regulation 13-1 for additional information regarding the treatment of steps in the freeboard deck of cargo ships.

## **Regulation 17 – Internal watertight integrity of passenger ships above the bulkhead deck**

### ***General – Steps in the bulkhead deck***

For the treatment of steps in the bulkhead deck of passenger ships see notes under regulation 13.

### ***Paragraph 1***

Watertight sliding doors with reduced pressure head complying with the requirements of MSC/Circ.541, as may be amended, should be in line with regulation 7-2.5.2.1. These types of tested watertight sliding doors with reduced pressure head could be immersed during intermediate stages of flooding.

### ***Paragraph 3***

These provisions are generally already accounted for in an alternative probabilistic manner by paragraphs 5.2.1 and 5.3.3 of regulation 7-2. Therefore, instead of the specified waterline, the waterline from conditions where  $s = 1$  can be used. The open end of air pipes means pipes without any weathertight valve.

## **Regulation 35-1 – Bilge pumping arrangements**

### ***Paragraph 2.6***

The drainage from enclosed ro-ro spaces or special category spaces should be of such capacity that two-thirds of the scuppers, freeing ports etc. on the starboard or port side are capable of draining off a quantity of water originating from both sprinkler pumps and fire pumps, taking into account a list of 1° for ships with a breadth of 20 m or more and 2° for ships with a breadth below 20 m and a trim forward or aft of 0.5°.



Scuppers on ro-ro decks should be provided, over the outlet grate, with a removable grill with vertical bars, to prevent large obstacles from blocking the drain. The grill may be placed obliquely against the side of the ship. The grill should have a height of at least 1 m above the deck and should have a free flow area of at least 0.4 m<sup>2</sup>, while the distance between the individual bars should be not more than 25 mm.

## APPENDIX

### GUIDELINES FOR THE PREPARATION OF SUBDIVISION AND DAMAGE STABILITY CALCULATIONS

#### 1 GENERAL

##### 1.1 Purpose of the Guidelines

1.1.1 These Guidelines serve the purpose of simplifying the process of the damage stability analysis, as experience has shown that a systematic and complete presentation of the particulars results in considerable saving of time during the approval process.

1.1.2 A damage stability analysis serves the purpose to provide proof of the damage stability standard required for the respective ship type. At present, two different calculation methods, the deterministic concept and the probabilistic concept are applied.

##### 1.2 Scope of analysis and documentation on board

1.2.1 The scope of subdivision and damage stability analysis is determined by the required damage stability standard and aims at providing the ship's master with clear intact stability requirements. In general, this is achieved by determining KG-respective *GM*-limit curves, containing the admissible stability values for the draught range to be covered.

1.2.2 Within the scope of the analysis thus defined, all potential or necessary damage conditions will be determined, taking into account the damage stability criteria, in order to obtain the required damage stability standard. Depending on the type and size of ship, this may involve a considerable amount of analyses.

1.2.3 Referring to SOLAS chapter II-1, part B-4, regulation 19, the necessity to provide the crew with the relevant information regarding the subdivision of the ship is expressed, therefore plans should be provided and permanently exhibited for the guidance of the officer in charge. These plans should clearly show for each deck and hold the boundaries of the watertight compartments, the openings therein with means of closure and position of any controls thereof, and the arrangements for the correction of any list due to flooding. In addition, Damage Control Booklets containing the aforementioned information should be available.

#### 2 DOCUMENTS FOR SUBMISSION

##### 2.1 Presentation of documents

The documentation should begin with the following details: principal dimensions, ship type, designation of intact conditions, designation of damage conditions and pertinent damaged compartments, KG-respective *GM*-limit curve.

## 2.2 General documents

For checking of the input data, the following should be submitted:

- .1 main dimensions;
- .2 lines plan, plotted or numerically;
- .3 hydrostatic data and cross curves of stability (including drawing of the buoyant hull);
- .4 definition of sub-compartments with moulded volumes, centres of gravity and permeability;
- .5 layout plan (watertight integrity plan) for the sub-compartments with all internal and external opening points including their connected sub-compartments, and particulars used in measuring the spaces, such as general arrangement plan and tank plan. The subdivision limits, longitudinal, transverse and vertical, should be included;
- .6 light service condition;
- .7 load line draught;
- .8 co-ordinates of opening points with their level of tightness (e.g. weathertight, unprotected);
- .9 watertight door location with pressure calculation;
- .10 side contour and wind profile;
- .11 cross and down flooding devices and the calculations thereof according to resolution A.266(VIII) with information about diameter, valves, pipes length and co-ordinates of inlet/outlet;
- .12 pipes in damaged area when the destruction of these pipes results in progressive flooding; and
- .13 damage extensions and definition of damage cases.

## 2.3 Special documents

The following documentation of results should be submitted.

### **2.3.1 Documentation**

#### 2.3.1.1 Initial data:

- .1 subdivision length  $L_s$ ;
- .2 initial draughts and the corresponding  $GM$ -values;
- .3 required subdivision index  $R$ ; and
- .4 attained subdivision index  $A$  with a summary table for all contributions for all damaged zones.

#### 2.3.1.2 Results for each damage case which contributes to the index $A$ :

- .1 draught, trim, heel,  $GM$  in damaged condition;
- .2 dimension of the damage with probabilistic values  $p$ ,  $v$  and  $b$ ;
- .3 righting lever curve (including  $GZ_{max}$  and range) with factor of survivability  $s$ ;
- .4 critical weathertight and unprotected openings with their angle of immersion; and
- .5 details of sub-compartments with amount of in-flooded water/lost buoyancy with their centres of gravity.

### **2.3.2 Special consideration**

For intermediate conditions as stages before cross-flooding or before progressive flooding, an appropriate scope of the documentation covering the aforementioned items is needed in addition.

\*\*\*

## ANNEX 3

**MODIFICATIONS TO THE DRAFT AMENDMENTS PREPARED BY MSC 81 FOR  
MATTERS RELATED TO FLOODING CASUALTIES\***

**MODIFICATIONS TO THE DRAFT AMENDMENTS TO SOLAS CHAPTER II-1**

**Draft regulation 8-1 – Return to port capability for passenger ships in the damaged condition**

1 Replace draft regulation 8-1 by the following:

**“Regulation 8-1\***

**Return to port capability for passenger ships in the damaged condition  
carrying [400][1,500] or more persons**

1 A passenger ship shall be designed to be capable of returning to port under its own power in compliance with regulations II-2/21.4 and II-2/21.5 when subject to flooding of any single watertight compartment.

2 A passenger ship shall be designed to be capable of returning to port either under power or under tow when subject to the damage extents prescribed in regulation 8.3.

2.1 For damage cases, where propulsion is lost:

- .1  $s_i = 1$ , when applying a wind pressure  $P$ , as defined in regulation 7-2.4.1.2, equal to  $240 \text{ N/m}^2$ . The wind pressure  $P$  used for ships in restricted service may be reduced subject to the approval of the Administration; and
- .2 the systems specified in regulations II-2/21.4.5 to II-2/21.4.14 shall remain operational and a safe area(s) shall be maintained in accordance with regulation II-2/21.5 as the ship proceeds back to port.

2.2 For damage cases, where propulsion is not lost:

- .1  $s_i = 1$ ; and
- .2 the systems specified in regulations II-2/21.4 shall remain operational and a safe area(s) shall be maintained in accordance with regulation II-2/21.5 as the ship proceeds back to port.

2.3 For the purpose of paragraphs 2.1 and 2.2 above,  $s_i$ , shall be calculated in accordance with regulation 7-2 with  $s_{\text{intermediate}, i}$  taken as unity.”

---

\* In operational situations, the master should exercise judgement as to whether these criteria provide adequate reserves of stability in the prevailing conditions.

---

\* Refer to paragraphs 2, 3 and 30 of annex 1 to document MSC 82/3.

**Draft regulation 22-1 – Flooding detection systems for passenger ships**

- 2 Replace draft regulation 22-1 by the following:

**“Regulation 22-1  
Flooding detection systems for passenger ships carrying 36 or more persons**

A flooding detection system for watertight spaces below the bulkhead deck shall be provided based on the guidelines developed by the Organization.\*”

---

\* Refer to the guidelines to be developed by the Organization.

**MODIFICATIONS TO THE DRAFT AMENDMENTS TO SOLAS CHAPTER II-2**

**Draft regulation 21 – Casualty threshold, safe return to port and safe areas**

- 3 Add the following footnote in the heading of regulation 21:

---

\* For flooding casualties, refer to regulation II-1/8-1.

- 4 Delete the text between square brackets in paragraphs 2 and 4.

- 5 Replace subparagraphs .13 and .14 by the following:

“.13 flooding detection systems; and  
.14 other systems determined by the Administration to be vital to damage control efforts.”

**Draft regulation 23 – Safety centre on passenger ships**

- 6 Delete the square brackets in paragraph 6.16.

\*\*\*

**ANNEX 4****DRAFT MSC CIRCULAR****PERFORMANCE STANDARDS FOR THE SYSTEMS AND SERVICES TO REMAIN OPERATIONAL ON PASSENGER SHIPS FOR SAFE RETURN TO PORT AND ORDERLY EVACUATION AND ABANDONMENT AFTER A CASUALTY**

1 The Maritime Safety Committee, at its [eighty-second session (29 November to 8 December 2006)], approved the Performance standards for the systems and services to remain operational on passenger ships for safe return to port after a casualty and the Performance standards for the systems and services to remain operational on passenger ships for orderly evacuation and abandonment after a casualty, set out in annexes 1 and 2 respectively, to provide additional guidance for the uniform implementation of SOLAS regulations II-1/8-1, II-2/21.4, II-2/21.5.1.2 and II-2/22.3.1, which were adopted by resolution [MSC.[...](82)] and are expected to enter into force on [entry into force date].

2 Member Governments are invited to bring the annexed Performance standards to the attention of passenger shipowners, shipbuilders, designers and other parties concerned.

## ANNEX 1

### **PERFORMANCE STANDARDS FOR THE SYSTEMS AND SERVICES TO REMAIN OPERATIONAL ON PASSENGER SHIPS FOR SAFE RETURN TO PORT AFTER A CASUALTY**

#### **General**

1 These performance standards provide additional guidance for the uniform implementation of SOLAS regulations II-2/21.4 and II-2/21.5.1.2, which require that, after a fire or flooding casualty, as defined in regulations II-1/8-1 and II-2/21.3, basic services be provided to all persons on board and that certain systems remain operational for safe return to port.

#### **Propulsion systems and their necessary auxiliaries and control systems**

2 Propulsion machinery and auxiliary machinery essential for the propulsion of the ship should remain operable.

#### **Ship's electrical-generation systems and their auxiliaries vital to the vessel's survivability and safety**

3 Electrical power should be available and sustainable for all essential services specified in SOLAS regulations II-2/21.4 and II-2/21.5.1.2, with due regard to such services as may be operated simultaneously. The application of regulation II-2/21.4 requires that other systems (e.g., engine-room ventilation, lighting of spaces outside safe areas not affected by the casualty, etc.) remain operational to support the functionalities listed therein.

#### **Steering systems and steering-control systems**

4 Steering systems and steering-control systems should be capable of manoeuvring the ship.

#### **Systems for fill, transfer and service of fuel oil**

5 Systems for internal fill, transfer and service of fuel oil should be capable of fuel transfer to active propulsion and power generation equipment.

#### **Internal communications system**

6 Internal communications should be achieved by any effective portable or fixed means of communications.

#### **External communications**

7 The ship should be capable of communicating via the GMDSS or the VHF Marine and Air Band distress frequencies even if the main GMDSS equipment is lost.



### **Fire main system**

8 The fire main should remain operational in all main vertical zones not directly affected by the casualty. Water for fire-fighting purposes should be available to all areas of the ship.

### **Fixed fire-extinguishing systems (gaseous and water)**

9 The automatic sprinkler system or any other fixed fire-extinguishing system designed to protect an entire space should be operational in all spaces not directly affected by the casualty.

### **Fire and smoke detection systems**

10 The fire detection system should remain operational in all spaces not directly affected by the casualty.

### **Bilge and ballast systems**

11 The bilge pumping systems and all associated equipment essential for its operation should be available in all spaces not directly affected by the casualty.

### **Navigation systems**

12 Equipment essential for navigation, position fixing and detection of risk of collision should be available. The ship should be capable of displaying the proper light configuration in compliance with the International Regulations for Preventing Collisions at Sea.

### **Basic services to safe areas**

13 The basic services specified in SOLAS regulation II-2/21.5.1.2 should be available to all safe areas, as defined in SOLAS regulation II-2/3.51.

### **Flooding detection system**

14 The flooding detection system should remain operational after a casualty.

### **Other systems vital to damage control efforts**

15 This includes any system that the Administration determines is vital to damage control pertaining to fire or flooding.

## ANNEX 2

### **PERFORMANCE STANDARDS FOR THE SYSTEMS TO REMAIN OPERATIONAL ON PASSENGER SHIPS FOR ORDERLY EVACUATION AND ABANDONMENT AFTER A CASUALTY**

#### **General**

1 These performance standards provide additional guidance for the uniform implementation of SOLAS regulation II-2/22.3.1, which requires that certain systems remain operational to support orderly evacuation and abandonment of the ship in the event of a fire.

#### **Fire main system**

2 The fire main should remain operational in all main vertical zones not directly affected by the casualty. Water for fire-fighting purposes should be available to all areas of the ship.

#### **Internal communications systems**

3 A means should be available for communicating orders to fire-fighting and damage control teams and personnel in charge of evacuation and abandonment.

#### **External communications**

4 The ship should be capable of communicating via the GMDSS or the VHF Marine and Air Band distress frequencies even if the main GMDSS equipment is lost.

#### **Bilge system**

5 The bilge pumping systems and all associated equipment essential for its operation should be available in all spaces not directly affected by the casualty.

#### **Ship's power for damage control and abandonment**

6 Electrical power should be available for the abandonment of the ship, including life-saving appliances and arrangements and the systems referred to regulation II-2/22.3.1, with due regard being paid to such services as may be operated simultaneously.

\*\*\*

**ANNEX 5****DRAFT MSC CIRCULAR****EXPLANATORY NOTES TO THE INTERIM GUIDELINES FOR ALTERNATIVE  
ASSESSMENT OF THE WEATHER CRITERION**

1 The Maritime Safety Committee, at its [eighty-second session (29 November to 8 December 2006)], approved the Explanatory Notes to the Interim Guidelines for alternative assessment of the weather criterion, set out in the annex, aiming at providing the industry with alternative means (in particular, model experiments) for the assessment of the severe wind and rolling criterion (weather criterion), as contained in the Code on Intact Stability for all Types of Ships Covered by IMO Instruments (resolution A.749(18)).

2 Member Governments are invited to bring the annexed Explanatory Notes to the Interim Guidelines to the attention of interested parties as they deem appropriate.

ANNEX

**EXPLANATORY NOTES TO THE INTERIM GUIDELINES FOR THE ALTERNATIVE ASSESSMENT OF THE WEATHER CRITERION**

**1 Introduction**

These explanatory notes provide an example of the alternative assessment of severe wind and rolling criterion (weather criterion) based on a series of model tests following the Interim Guidelines for the alternative assessment of the weather criterion contained in MSC.1/Circ.1200, for better understanding of the alternative procedures. Here the weather criterion specified in paragraph 3.2 of the Code\* is referred as “standard weather criterion”, whereas the Interim Guidelines (MSC.1/Circ.1200) are referred as “Guidelines”.

**2 The tested ship**

The principal particulars, general arrangement and GZ curve of the RoPax ferry used in this example are shown in table 2.1, figure 2.1 and figure 2.2 respectively.

**Table 2.1 Principal particulars**

Length between perpendiculars: Lpp [m]	170.0	Area of bilge keels: Abk [m <sup>2</sup> ]	61.32
Breadth: B [m]	25.0	Vertical centre of gravity: KG [m]	10.63
Depth: D [m]	14.8	Metacentric height: GoM [m]	1.41
draft: d [m]	6.6	Flooding angle: $\phi_f$ [degrees]	39.5
Displacement: W [tonnes]	14,983	Rolling period: Tr [sec]	17.90
Blockage coefficient: Cb	0.521	Lateral projected area: AL [m <sup>2</sup> ]	3,433.0
B/d	3.79	Height to centre of AL above WL: Hc [m]	9.71

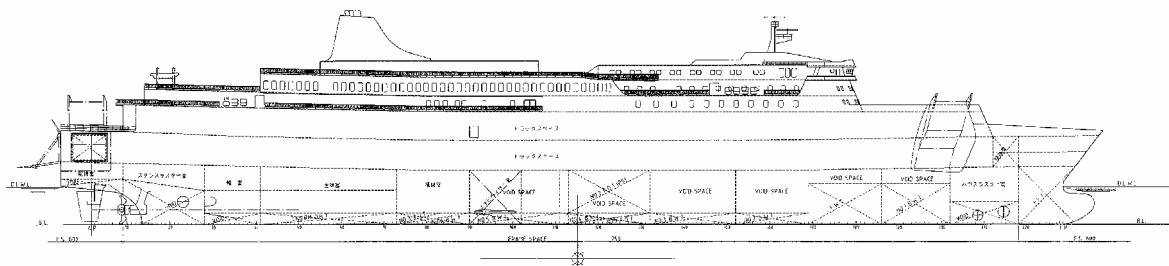

**Figure 2.1 General arrangement**

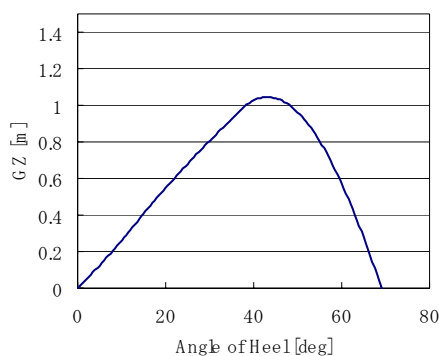

**Figure 2.2 GZ curve**

\* Throughout these Explanatory Notes, the reference to the Code means the reference to the Code on Intact Stability for all Types of Ships Covered by IMO Instruments (resolution A.749(18)), as amended.

### 3 The determination of the wind heeling lever $l_{wl}$

#### 3.1 Model set-up

##### 3.1.1 Ship model used for wind tests

The model for the wind test was built following paragraph 1.2.1 of the Guidelines. The length ( $L_{pp}$ ) of the model was 1.5 m (scale: 1/113). The lateral projected area in upright condition was 0.267 m<sup>2</sup>. Compared to the cross section of the wind tunnel (3 m in breadth and 2 m in height), the blockage ratio was 4.5%.

##### 3.1.2 Ship model used for drifting tests

The model for the drifting test was built following paragraph 1.2.2 of the Guidelines with bilge keels of greater than 10 mm in breadth. The length of the model was 2 m (scale: 1/85).

#### 3.2 Wind tests

**3.2.1** The arrangement for the wind tunnel tests is shown in figure 3.1. The connection between the model and load cell had a rotating device for testing the model in heeled conditions. In heeled conditions the height of the model was adjusted by the adjusting plate to keep the displacement constant when floating freely. The change of trim due to heel was neglected.

**3.2.2** In order to keep the blockage ratio less than 5%, the floor plate was set to the same level of the floor of the tunnel. The gap between the model and the floor plate was kept within approximately 3 mm and covered by soft sheets for avoiding the effect of downflow through the gap\*.

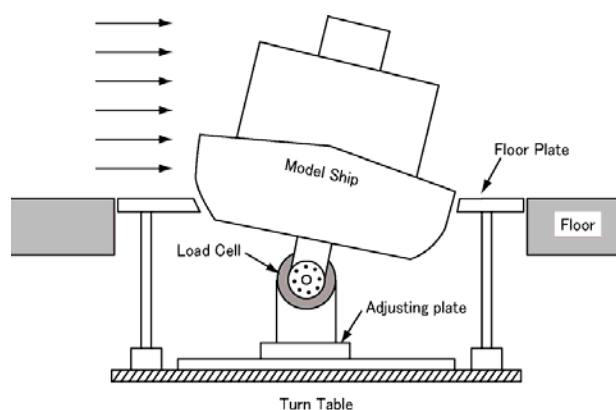

**Figure 3.1** Arrangement for wind tunnel tests

**3.2.3** The vertical distribution of wind speed is shown in figure 3.2. For the test arrangement (figure 3.1), the height of the ship model from the floor was approximately 19 cm in upright condition. This means that the lower half of the model is placed in the boundary layer. The distributions of wind speed in the lateral and longitudinal directions were almost uniform (deviation less than 1%) around the model.

\* In order to simplify the execution of the experiments and to avoid the need for the building of appropriate floor plates for each heeling angle, the gap could be filled by water. However, in this case, if any buoyancy effect occurs in the model due to the particular setup, then it is to be properly accounted for in the subsequent analysis of the data.

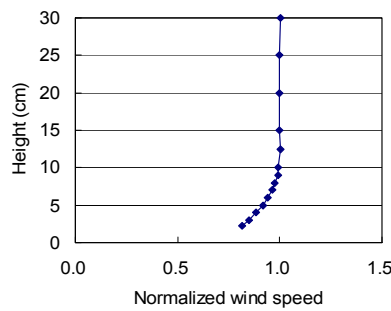

**Figure 3.2 Vertical distribution of wind speed**

**3.2.4** The wind speed was varied from 5 m/s to 15 m/s in upright condition and confirmed that the drag coefficient is almost constant in this speed range. For the full tests a wind speed of 10 m/s was used, corresponding to a Reynolds' number of  $1.52 \times 10^5$ , as defined by the following equation:

$$Re = \frac{U_{\infty} B}{\nu} \quad (\text{N-3.1})$$

where  $U_{\infty}$  is the uniform wind speed outside the boundary layer,  $B$  is the breadth of the model and  $\nu$  is the kinematic viscosity coefficient of air.

**3.2.5** The horizontal force  $F_{wind}$ , the heeling moment  $M$  and the lift force  $L$  were measured by the load cell. The heeling moment  $M$  was converted to the one with respect to point  $O$ , defined as  $M_{wind}$ , by the following equation:

$$M_{wind} = M - F_{wind} l \cos \phi + L \cdot l \sin \phi \quad (\text{N-3.2})$$

where  $l$  is the distance from the centre of the load cell to point  $O$ . The point  $O$  is defined as the cross point of the centreline of the ship and waterline in upright condition.

### 3.3 Drifting tests

**3.3.1** The drifting test was carried out in a basin with dimensions of 50 m in length, 8 m in breadth and 4.5 m in depth. The set-up is shown in figure 3.3. To connect the model, the load cell and the heaving rod the same connection setup as in the wind tunnel tests was used. The horizontal force  $F_{water}$  and the heeling moment  $M$  were measured by the load cell. They were determined as time averages in stationary condition after the transient phase, which appears when the carriage starts to run. The heeling moment with respect to point  $O$ , defined as  $M_{water}$ , was calculated similarly to the wind tunnel tests. However, the last term in equation (N-3.2) is not necessary since the vertical force is globally zero due to heave-free arrangement.

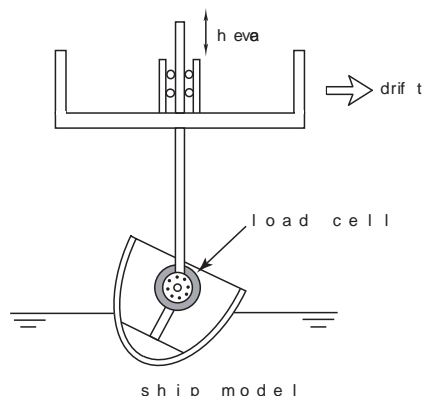

**Figure 3.3 The arrangement for drifting test**

**3.3.2** The drifting speed should be determined to make the drifting force equal to  $F_{wind}$  as defined by equation (1.2) of the Guidelines in model scale. The wind speed should be assumed to be 26 m/s in ship scale. However, in this experiment, the speed was varied to cover the expected range of the wind drag coefficient,  $C_D$ , since the wind tunnel tests were carried out after the drifting tests.

### 3.4 Results of wind tests

**3.4.1** The measured drag coefficient ( $C_D$ ), lift coefficient ( $C_L$ ) and heeling moment coefficient ( $C_M$ ) are shown in figure 3.4. They are non-dimensionalized by the following equations:

$$\begin{pmatrix} C_D \\ C_L \end{pmatrix} = \begin{pmatrix} F_{wind} \\ L \end{pmatrix} / \left( \frac{1}{2} \rho_{air} U^2 A_L \right) \quad (\text{N-3.3})$$

$$C_M = M_{wind} / \left( \frac{1}{2} \rho_{air} U^2 \frac{A_L^2}{L_{pp}} \right) \quad (\text{N-3.4})$$

**3.4.2** In the figure the angle of heel is defined as positive when the ship heels to lee side (refer to figure 3.1). The broken line is the heeling moment coefficient of the standard weather criterion, calculated from equation (N-3.5), which is derived from the equation in paragraph 3.2.2.2 of the Code. However, in order to be compared with the test results,  $Z$  is replaced by the height of the centre of the lateral projected area above waterline, i.e.  $Hc$  in table 2.1.

$$M_{wind} = P \cdot A \cdot Z \quad [\text{N-m}] \quad (\text{N-3.5})$$

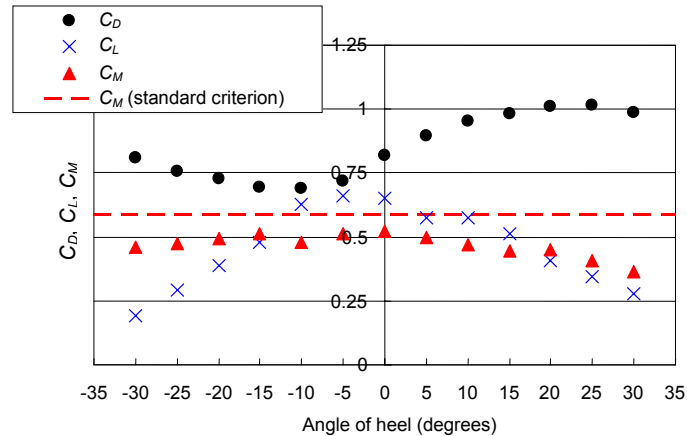

**Figure 3.4 Measured drag coefficient ( $C_D$ ), lift coefficient ( $C_L$ ) and heeling moment coefficient ( $C_M$ )**

**3.4.3** It is characteristic in the figure that all the quantities ( $C_D$ ,  $C_L$  and  $C_M$ ) vary significantly with heel angle. As for the heeling moment, it is smaller than the standard criterion and further reduces when the ship heels, especially to lee side. The lift force is not so small and close to the drag force when the heeling angle is  $-5^\circ$  (weather side). However, the adjustment of the vertical position of the model is not necessary since the lift force is 0.7% of the displacement of the ship in a wind speed of 26 m/s.

**3.4.4** For comparing the test results with  $Z$  in equation (N-3.5), the measured heeling moment was converted to the height of the centre of wind force above waterline,  $l_{wind}$ , by the following equation:

$$l_{wind} = M_{wind} / F_{wind} \quad (N-3.6)$$

**3.4.5** The result is shown in figure 3.5. It can be observed that the centre of wind force is also a function of heel angle.

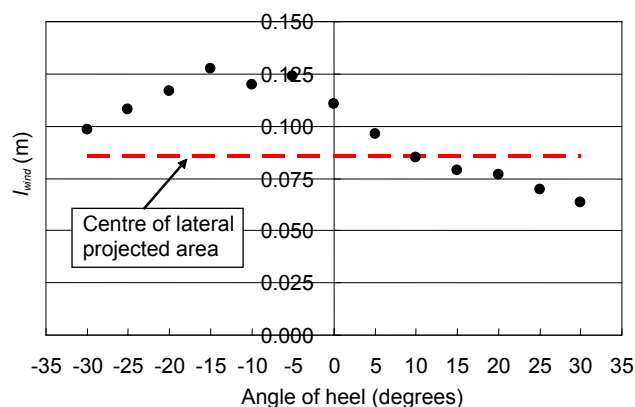

**Figure 3.5 Height of the centre of wind force above waterline (model scale)**



### 3.5 Results of Drifting Tests

**3.5.1** In the same manner as equation (N-3.6), the measured heeling moment generated by the drift motion,  $M_{water}$ , was converted into the height of the centre of drift force above waterline,  $l_{water}$ . The values normalized by the draft are shown in figure 3.6, where the angle of heel is positive when the ship heels to the drift direction as shown in figure 3.3.

**3.5.2** It can be observed that, in the examined case, the centre of drifting force is above half draft (which is the assumption in the standard criterion) and is generally above the waterline. This phenomenon appears when breadth/draft ratio is large, due to the pressure distribution on the bottom.

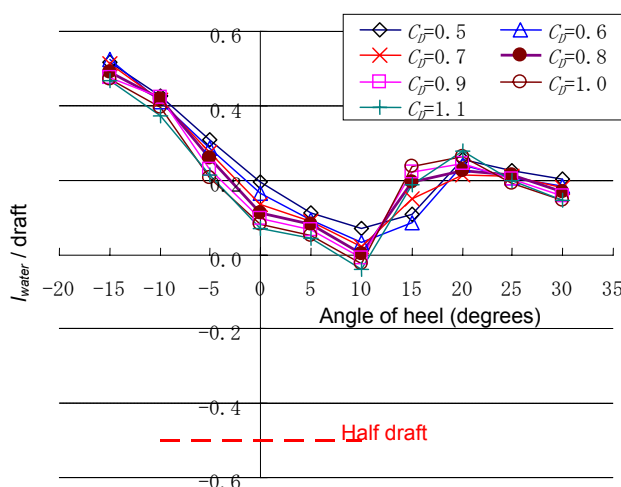

**Figure 3.6 Height of the centre of drift force for assumed wind drag coefficients**

### 3.6 Determination of $l_{wl}$

**3.6.1** The heeling moments evaluated by wind tests,  $M_{wind}$ , and drifting tests,  $M_{water}$ , were substituted into equation (N-3.7) (the same as equation (1.1) of the Guidelines) and the wind heeling lever,  $l_{wl}$ , was calculated as a function of heel angle as shown in figure 3.7 and figure 3.8.

$$l_{wl} = \frac{M_{wind} + M_{water}}{\Delta} \quad (\text{N-3.7})$$

**3.6.2** In figure 3.7, the heeling levers due to wind ( $M_{wind}/\Delta$ ) and drift motion ( $M_{water}/\Delta$ ) are also included. In both figures,  $l_{wl}$  at angles greater than  $30^\circ$  is assumed to keep the same value as at  $30^\circ$  (see paragraph 1.6 of the Guidelines). Figure 3.7 shows that, in the considered case, the wind heeling lever estimated by using the complete procedure, i.e. by using wind and drift tests, is sensibly smaller than that required by the standard weather criterion.

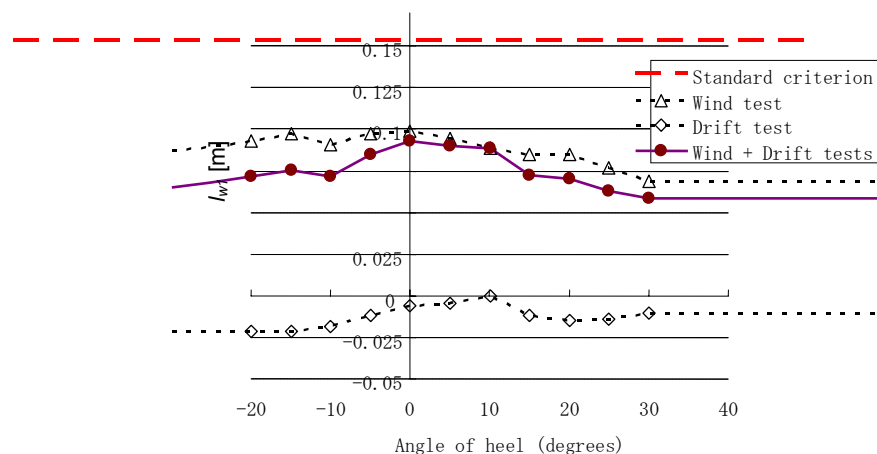

**Figure 3.7** Wind heeling lever,  $l_{wl}$ , evaluated by the tests

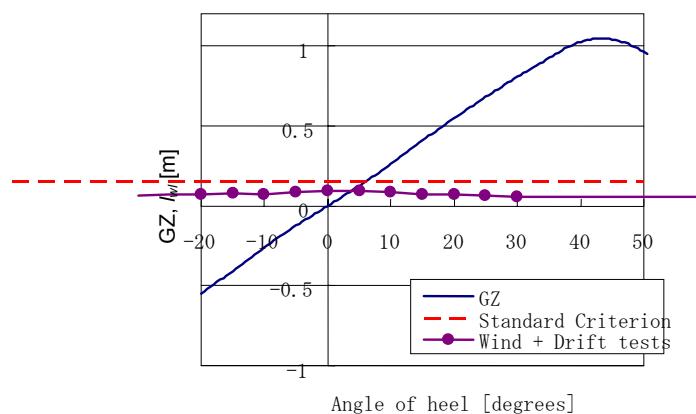

**Figure 3.8** Wind heeling lever,  $l_{wl}$ , compared with the GZ curve

#### 4 The determination of the roll angle $\phi_1$

##### 4.1 Model basin

The model basin used for roll decay tests and rolling motion tests in waves was the same used for the drifting tests (50 m in length, 8 m in breadth and 4.5 m in depth). The overall length of the model (2.14 m) was small enough compared to the breadth of the basin.

##### 4.2 Model set-up

**4.2.1** The model was the same used for the drifting tests ( $L_{pp} = 2$  m, scale: 1/85). It was built up to the upper vehicle deck, till which buoyancy is included in the stability calculation. The top was built open, but water did not enter into the model in waves with the largest steepness.

**4.2.2** The model was ballasted to the loading condition for the ship, as shown in table 2.1. To ensure correct displacement and attitude, the colour of the model was changed between above and below the load line. The GM as measured by an inclining test was 1.67 cm, corresponding to an 0.7% error to the scaled value of the ship. The natural roll period was also measured to be 1.92 s, corresponding to an 1.2% error.

### 4.3 General experimental set-up

4.3.1 The roll motion was measured by means of an inclinometer, for which uniform frequency response was confirmed. Soft and slack cables were attached from the carriage to the model for power supply and signal recording. The whole ship motion was recorded by a video camera.

4.3.2 The wave elevation was measured by wave probes for the waves corresponding to the minimum and the maximum frequency used in the tests. This was done without the model at 3 locations along the length of the basin, spanning a length wider than the expected drift range of the model, i.e. 7.1 m. The maximum variations among the three measuring probes with respect to the required value of wave height and wave period were 4% and 1% respectively.

### 4.4 Direct measurement procedure

4.4.1 From the table of wave steepness (table 2.1 of the Guidelines) the assumed wave steepness,  $s$ , for this ship is 0.0383 (1/26.1). Roll amplitude of the model was measured in beam waves with this steepness. Moreover, the waves with  $s = 1/40$  and  $1/60$  were also used for the alternative procedures mentioned later. The maximum wave height was 27.8 cm, which is close to the maximum limit of the wave generator.

4.4.2 The model was freely drifting for avoiding effects of guide system and guide ropes were fitted to the model on the centreline at the stem and stern at a vertical height around the centre of gravity. The periodic yaw motion was small, but the change of mean heading angle was controlled by the ropes carefully by human hands to keep it within  $15^\circ$ . The carriage followed the mean drift motion of the model. When the heading was corrected by the ropes with large force, the corresponding part of the measured record was neglected in the analysis. The effect of correction was negligible in small waves, however in high waves the correction was not easy in some cases.

4.4.3 The measured roll responses were subjected to Fourier analysis to extract the components at encounter frequencies. The results are shown in figure 4.1 for all wave steepnesses. Due to the nonlinearity of roll damping, the non-dimensional roll amplitudes are larger in smaller steepness. On the other hand, due to the linearity of GZ curve (see figure 2.2) the peak frequencies do not significantly change even in high waves. The roll peak amplitude at the required steepness, i.e.  $s = 1/26.1$ , was  $\phi_r = 27.6^\circ$  from the experiments. According to formula (2.1) of the Guidelines, the “angle of roll to windward due to wave action”,  $\phi_1$ , is thus determined as  $\phi_1 = 0.7\phi_r = 19.3^\circ$ .

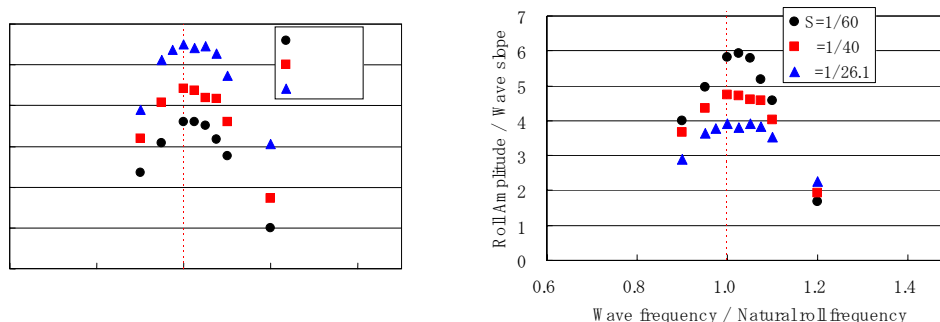

Figure 4.1 Roll amplitude in beam regular waves (left: in degrees, right: non-dimensional)

#### 4.5 Alternative procedures

In this section, alternative procedure 1 (Three steps procedure) is addressed.

##### 4.5.1 Roll decays test

**4.5.1.1** In calm water the model was initially inclined up to heel angles larger than 25° and released with zero roll angular velocity. Four tests with different initial angles were conducted. As an example, the relation of  $\phi_m$  (mean roll angle) and  $\delta\phi$  (decrement of roll angle per half cycle) for a test is shown in figure 4.2.

**4.5.1.2** The measured nonlinear roll damping coefficient,  $N$ , as a function of roll amplitude is shown in table 4.1. The dependence of  $N$  coefficient on roll amplitude is small since the linear component (wave making damping) is small for this ship.

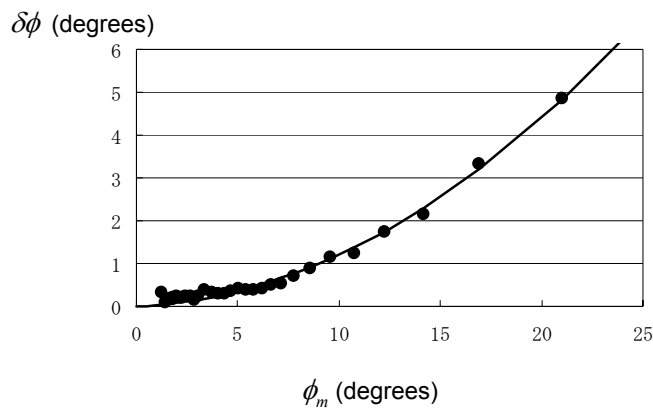

**Figure 4.2** An example of roll decay test

**Table 4.1** Roll damping coefficient  $N$

Roll Amplitude	$N$ [1/degrees]
10.0	0.0122
12.5	0.0117
15.0	0.0113
17.5	0.0111
20.0	0.0109
22.5	0.0108
25.0	0.0106

##### 4.5.2 Effective wave slope coefficient $r$

To measure the effective wave slope coefficient  $r$ , two options are described in paragraph 2.6.1.2 of the Guidelines. Here the results of roll motion tests, mentioned in paragraph 4.4 above, have been used for  $s = 1/60$  and the value  $r = 0.759$  was obtained.

### 4.5.3 Determination of roll angle $\phi_1$

By iterative calculation as described in 2.6.1.2 of the Guidelines (Third step),  $\phi_r$  was determined as  $27.9^\circ$  and thus  $\phi_1 = 0.7\phi_r = 19.5^\circ$ , which is very close to the estimation of direct measurement procedure (section 4.4 above). One reason for this agreement is the almost linear characteristics shown by the GZ curve up to  $20^\circ$  (see figure 2.2).

## 5 The assessment of weather criterion

**5.1** The comparison of the different assessments of the weather criterion using experimental results is summarized in table 5.1. In the table all the possible combinations of the wind tests and the drifting tests for estimating  $l_{wl}$  are included (see paragraph 1.5 of the Guidelines). As for  $\phi_1$ , the standard criterion (paragraph 3.2.2.3 of the Code) and the result of the direct measurement procedure are included. The results of the three steps procedure can be omitted here since the estimated  $\phi_1$  was almost equal to the one of direct measurement procedure for this ship. The PIT estimation is reported in section 6 below. The last line of table 5.1 shows the critical values of KGs, in which  $b/a=1$ . These last results are to be taken with some caution, since the effects of changing the vertical centre of gravity on  $T_r$  and on the other quantities related to roll motion including  $\phi_1$  have been neglected. A considerable extension of the experimental tests would have been indeed required to correctly evaluate the limiting KG curve.

**Table 5.1 Assessment of weather criterion**

$l_{wl}$	Standard Weather Criterion	Wind test + Drift test	Wind test + draft/2	Wind test (upright) + Drift test	Wind test (upright) + draft/2	Standard Weather Criterion	Wind test + Drift test	Wind test + draft/2	Wind test (upright) + Drift test	Wind test (upright) + draft/2
$\phi_1$	Standard Weather Criterion					Direct Procedure (or Three Steps Procedure)				
$l_{wl}$ [m]	0.153	Function of heel angle			0.125	0.153	Function of heel angle			0.125
$r$ [-]	1.096					0.759 (Three Steps Procedure)				
$T_r$ [sec]	16.3					17.9				
$s$ [-]	0.0431					0.0383				
$\phi_1$ [deg]	15.4					19.3				
$\phi_0$ [deg]	6.1	3.7	4.9	3.8	5.0	6.1	3.7	4.9	3.8	5.0
$\phi_0 - \phi_1$ [deg]	-9.3	-11.7	-10.4	-11.6	-10.4	-13.2	-15.7	-14.4	-15.5	-14.3
$\phi_r$ [deg]	39.5									
Area a [rad-m]	0.075	0.063	0.069	0.063	0.070	0.111	0.096	0.103	0.095	0.106
Area b [rad-m]	0.224	0.295	0.259	0.276	0.247	0.224	0.295	0.259	0.276	0.247
$b/a$ [-]	2.99	4.71	3.76	4.41	3.51	2.02	3.09	2.51	2.90	2.34
Crit. KG [m]	11.48	11.88	11.68	11.79	11.62	11.35	11.82	11.59	11.73	11.52

**5.2** Table 5.1 shows that the alternative assessment by model experiment can change the ratio of areas,  $b/a$ , significantly with respect to the standard criterion, whereas the changes in the limiting value of the vertical centre of gravity are more contained. For this ship, the increased  $\phi_1$  obtained by experiments makes  $b/a$  smaller, and the  $l_{wl}$  evaluated through all the combinations of the wind tests and drifting tests, complete procedures and simplified procedures, tends to make  $b/a$  larger than the standard weather criterion as contained in paragraph 3.2 of the Code. It has to be noted, however, that the fluctuations are related to the large variation in the vertical centre of hydrodynamic pressure in drift motion of this ship. More extensive confirmation are awaited from the experience gained through the application of the Interim Guidelines.

## 6 Alternative procedure 2: Parameter identification technique (PIT)

### 6.1 Introduction

**6.1.1** The PIT technique is a general methodology for the determination of the numerical values for a certain number of parameters in a given analytical model, in such a way that the model can represent the physical behaviour of the system under analysis in the given conditions. Although the PIT technique is also suitable for the direct analysis of roll decays in calm water in order to obtain the ship natural frequency and the damping parameters, the roll motion of a ship in beam sea is dealt with in this document.

**6.1.2** The general idea on which the PIT is based is that the given analytical model is assumed to be able to predict the amplitude of roll motion of the ship in beam sea, and this model is characterized by a general form with a certain number of free parameters. The free parameters should be fixed in order to obtain the best agreement between available experimental data and numerical predictions from the model. When such parameters are determined, the model is assumed to be suitable for extrapolation. In the case of roll motion in beam sea, the model parameters is fit by using the ship roll response data for a small steepness in order to predict the ship behaviour at a larger steepness for which direct experiments cannot be carried out, or for which direct experiments are not available.

**6.1.3** The general equation assumed suitable for the modelling of roll motion in beam sea is, according to the Guidelines, the following:

$$\left\{ \begin{array}{l} \ddot{\phi} + d(\dot{\phi}) + \omega_0^2 \cdot r(\phi) = \omega_0^2 \cdot \pi \cdot s \cdot \xi \left( \frac{\omega}{\omega_0} \right) \cdot \cos(\omega \cdot t) \\ d(\dot{\phi}) = 2\mu \cdot \dot{\phi} + \beta \cdot \dot{\phi} |\dot{\phi}| + \delta \cdot \dot{\phi}^3 \\ r(\phi) = \phi + \gamma_3 \cdot \phi^3 + \gamma_5 \cdot \phi^5 \\ \xi \left( \frac{\omega}{\omega_0} \right) = \alpha_0 + \alpha_1 \cdot \frac{\omega}{\omega_0} + \alpha_2 \cdot \left( \frac{\omega}{\omega_0} \right)^2 \end{array} \right. \quad (\text{N-6.1})$$

**6.1.4** Where the following parameters are in principle to be considered as free (units are reported assuming the roll angle to be measured in radians):

- Damping coefficients:  $\mu$  (linear damping (1/s)) ,  $\beta$  (quadratic damping (1/rad)),  $\delta$  (cubic damping (s/rad<sup>2</sup>));
- Natural frequency  $\omega_0$  (rad/s);
- Nonlinear restoring coefficients:  $\gamma_3$  (cubic term (nd) ),  $\gamma_5$  (quintic term (nd) );
- Effective wave slope coefficients:  $\alpha_0$  (constant (nd) ),  $\alpha_1$  (linear term (nd) ),  $\alpha_2$  (quadratic term (nd) ).

**6.1.5** The wave steepness  $s$ , as well as the forcing frequency  $\omega$  (to be measured directly from the roll time histories in order to account for Doppler effect if the drift speed is large), are given data from experiments.

**6.1.6** The total number of free parameters is, thus, in principle, equal to 9. Such a large number of parameters can be effectively determined from experimental data only when the number of experiments is large, i.e., at least two (but is better three) wave steepnesses leading to response curves spanning a large range of rolling angles from the linear range (below, say,  $10^\circ$ ) up to the nonlinear range (say, at least  $40^\circ$ ). In addition, experimental data should span a large range of frequencies from low to high frequency range (say,  $\frac{\omega}{\omega_0}$  from about 0.8 or lower to about 1.2 or higher). The necessity of spanning such a large domain is due to the fact that different parameters have a different importance in different ranges.

**6.1.7** While damping plays an important role mostly around the peak region, the effective wave slope is better determined if the low frequencies region of the response curve is also available. Linear terms in both damping and restoring are dominant in the region of small rolling amplitudes, while the effects of nonlinear terms are noticeable only in the region of large rolling amplitudes. The roll response curve tends to bend to the low frequency region when  $\overline{GZ}$  is of the softening type, and towards the high frequency region when  $\overline{GZ}$  is of the hardening type. Both type of bending could be noticeable when the righting lever is of the S-type.

**6.1.8** The general use of the PIT in the framework of the experimental determination of the roll angle  $\phi_r$ . (See the Guidelines) will likely to be similar to that of the Three steps procedure, i.e. as follows:

- .1 carry out experiments at a *single* steepness  $s_{\text{exp}}$  smaller than the required one  $s_{\text{req}}$  ;
- .2 determine model parameters in order to fit the experiments at  $s_{\text{exp}}$  ;
- .3 utilize the obtained parameters in order to predict the peak of the ship roll response at  $s_{\text{req}}$  ;

**6.1.9** Since only one steepness is likely to be available, the number of parameters should be reduced in order to achieve convergence of the methodology without spurious effects on undetectable parameters. A reduced model is then to be used.

**6.1.10** On the bases of a series of studies and on the experience gained in the past (see, e.g., [1][2]), the following reduced model can be proposed when only one steepness is available:

1 steepness reduced model:

$$\ddot{\phi} + \beta \cdot \dot{\phi} + \omega_0^2 \cdot (\phi + \gamma_3 \cdot \phi^3) = \omega_0^2 \cdot \pi \cdot s \cdot \alpha_0 \cdot \cos(\omega \cdot t) \quad (\text{N-6.2})$$

where the damping has been considered to be purely quadratic due to the fact that only one amplitude response curve is available. The frequency dependence of the effective wave slope has been dropped because we are mainly interested in this context in the ship response at peak, and so the tails are of less (or none) importance for the final evaluation of  $\phi_r$ , (even if the low

frequency tail of the roll response is fundamental for the fitting of the value of  $\alpha_0$ ). As a note, the coefficient  $\alpha_0$  in the reduced model (N-6.2) corresponds to the effective wave slope “ $r$ ” of the Three Steps Procedure. A cubic nonlinear restoring term has been kept, but it can be removed if the  $\overline{GZ}$  curve is sufficiently linear in the expected response range, or if there is no evidence of bending from the experimental response curve (provided the experimental peak is sufficiently large to allow the identification of the possible nonlinear behaviour).

**6.1.11** In the case where two response curves are available determined at two different steepnesses, it is possible to introduce an additional linear damping term and an additional 5th degree restoring term:

2 steepness reduced model:

$$\ddot{\phi} + 2\mu \cdot \dot{\phi} + \beta \cdot \dot{\phi} |\dot{\phi}| + \omega_0^2 \cdot (\phi + \gamma_3 \cdot \phi^3 + \gamma_5 \cdot \phi^5) = \omega_0^2 \cdot \pi \cdot s \cdot \alpha_0 \cdot \cos(\omega \cdot t) \quad (\text{N-6.3})$$

**6.1.12** Regarding the damping term in the previous reduced models, in general the quadratic damping component seems to be more suitable for the analysis of hulls with bilge keels or with an expected large vortex generation. On the other hand, the substitution of the quadratic term  $\beta \cdot \dot{\phi} |\dot{\phi}|$  with a cubic term  $\delta \cdot \dot{\phi}^3$  could be more suitable for bare hulls.

**6.1.13** The use of different nonlinear damping models, can lead to different results in the prediction of the final rolling amplitude. For this reason, in the absence of sufficient evidence for the selection of one nonlinear model versus the others, the use of the average of the two predicted peak rolling amplitudes is recommended. A pure linear model, on the other hand, is almost always inadequate for the representation of roll damping at zero speed.

## 6.2 General comments on PIT implementation

**6.2.1** The PIT technique needs to be implemented in a suitable computer code, and it is not amenable to hand calculations. A block diagram for the implementation of the PIT is reported in figure 6.2. As it can be seen, the procedure is based on two main components:

- .1 a differential equation solver used to determine the roll response predicted by the model for different trial sets of parameters; and
- .2 a suitable minimization algorithm used to achieve the optimum set of parameters by minimizing the sum of the squared differences between experimental and predicted roll amplitudes.

**6.2.2** The differential equation solver could be basically of two types:

- .1 Exact time domain solver: it numerically solves the general differential equation (N-6.1) by using discrete time step algorithms (like the Runge-Kutta) for a certain number of forcing periods, until the roll steady state is achieved. Finally, each time history is analysed in order to get the steady state roll amplitude; and
- .2 Approximate frequency domain solver: it uses an analytical approximate solution of the differential equation (N-6.1) in order to determine the nonlinear roll response curve in frequency domain. Typically used analytical methods are the



harmonic balance technique, the multiple scale method and the averaging technique [3].

**6.2.3** The two approaches have different pros and cons.

**6.2.4** Time domain integration requires more computational time, but it solves the original differential equation without approximations (apart from numerical accuracy). On the other hand, in case of strong bending of the response curve, when multiple solutions are possible for the same forcing frequency, then care must be taken in the numerical determination of the roll amplitude in order to correctly deal with all the present solutions (see figure 6.1).

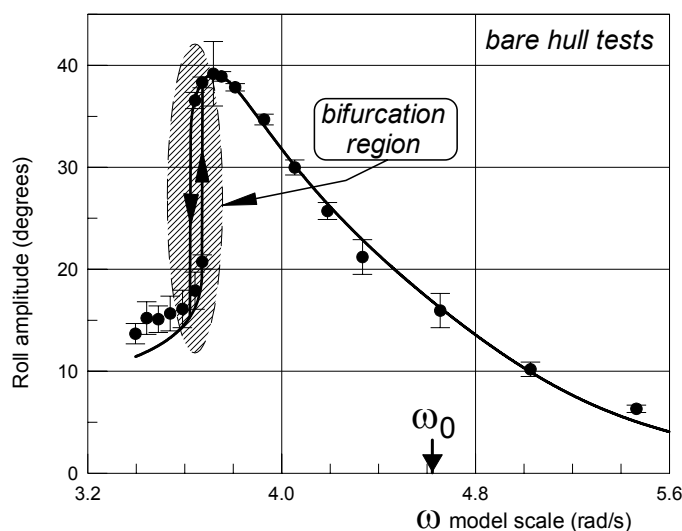

**Figure 6.1 Example of experimental and numerically fitted nonlinear response curve in the case of softening  $\overline{GZ}$**

**6.2.5** A typical numerical method that could be used for dealing with this problem is based on the “frequency sweep” idea, where the forcing frequency is slowly changed in the time domain integration from the highest value to the lowest one, and then vice-versa, in order to detect jumps due the presence of bifurcations (see figure 6.1).

**6.2.6** Analytical approaches are approximate solutions, and this is the biggest drawback. However, the agreement between numerical simulations and analytical solutions is often surprisingly good, and more than sufficient for practical applications. In addition, if the fitting of the experimental data is based on an analytical method, and the same analytical method is used for the extrapolation, i.e. a consistent methodology is used without mixing the analytical and the numerical approach, good agreement is expected between numerical and analytical approaches. The analytical methods are usually much faster than the direct time domain integration, and they are able to determine multiple stable solutions in region where more than one solution is present, making the dealing with this type of problem easier.

**6.2.7** The differences in the final predicted roll peak  $\phi_r$ , between the application of the numerical and of the analytical approach are expected to be below the usual experimental uncertainty (that could be considered of the order of  $\pm 2^\circ$ ).

**6.2.8** The minimization algorithm could be any reliable minimization procedure (e.g., Levenberg-Marquardt method, or any more advanced stochastic/deterministic method).

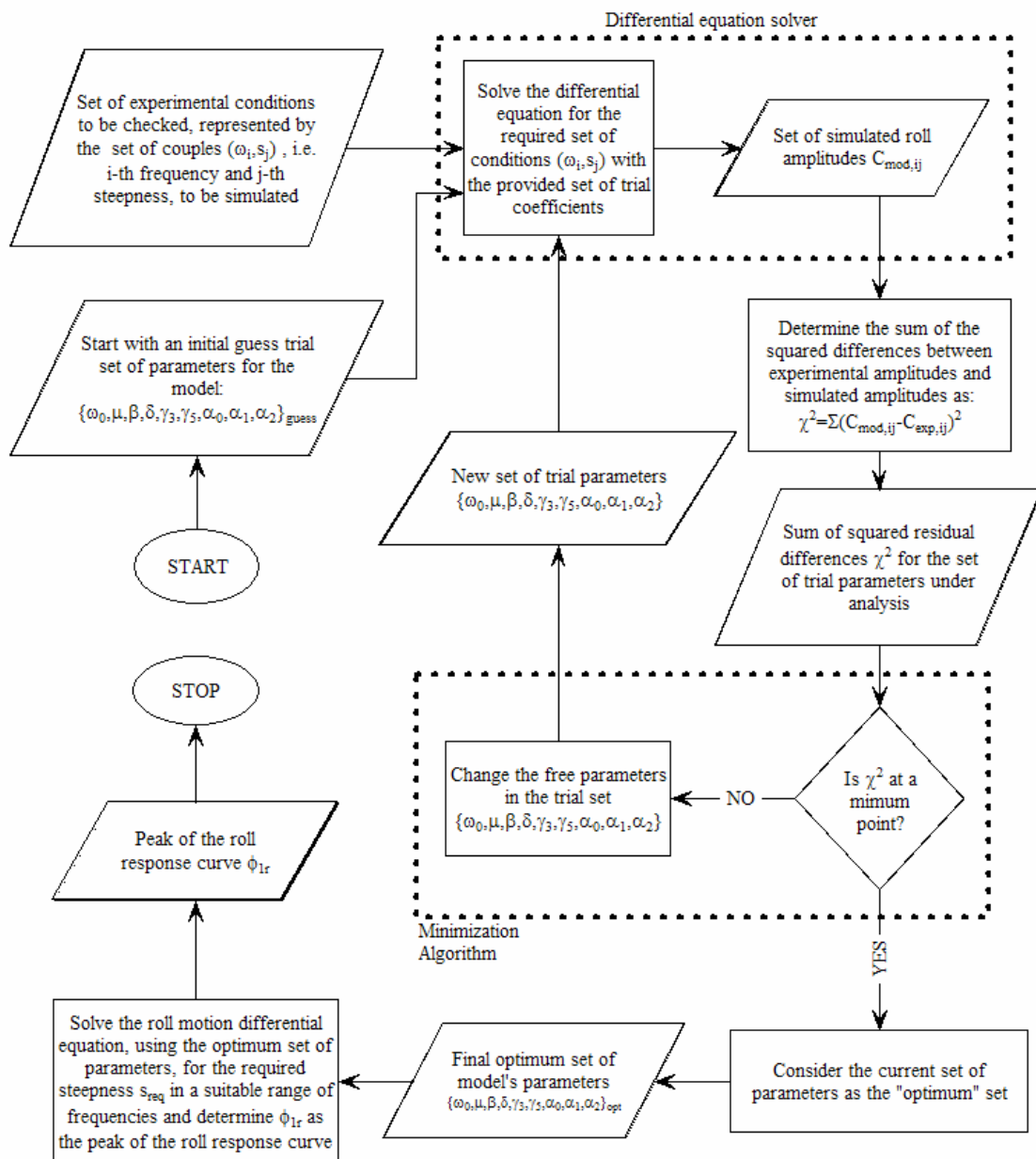

Figure 6.2 Block diagram for the PIT procedure

### 6.3 Application of PIT to experimental data

6.3.1 The same experimental data used in the Alternative Procedure 1 above have been used in the application of the PIT. Scope of this application is to predict the roll response peak for the tested required steepness  $s = 0.0383$  by starting from available data at smaller steepnesses, i.e. 1/40 and 1/60. The following three calculations have been carried out:

- .1 Calculation 1: prediction of  $\phi_{1r}$  by fitting of the model on the steepness  $s = 1/60$ ;
- .2 Calculation 2: prediction of  $\phi_{1r}$  by fitting of the model on the steepness  $s = 1/40$ ;

.3 Calculation 3: prediction of  $\phi_r$  by fitting of the model on both the steepness  $s = 1/40$  and  $s = 1/60$ ;

**6.3.2** In the case of calculations 1 and 2, being only one steepness available, the reduced model (N-6.2) has been used, and because of the linearity of the  $\overline{GZ}$  curve and because of the absence of any evident bending in the response curve it has been assumed that  $\gamma_3 = 0$ .

**6.3.3** In the case of calculation 3, being two steepnesses available, additional terms have been added. Two different analytical model have then been used: the first model is exactly the same as that used for calculation 1 and 2, whereas in the second model the linear damping coefficient  $\mu$  has been left free (see (N-6.3)). However, in both cases, the assumption of linear restoring, i.e.,  $\gamma_3 = 0$  and  $\gamma_5 = 0$ , has been kept.

**6.3.4** In all cases the roll response curve has been determined through an analytical approximate nonlinear frequency domain approach where the response curve is obtained by means of the harmonic balance technique [3].

**6.3.5** The used analytical models and the results obtained through the application of the PIT are summarized in Table 6.1, while a global picture of the roll response curves is given from figure 6.3 to figure 6.6.

**6.3.6** From the analysis of the reported exercise it seems that the PIT together with the proposed analytical reduced models is able to reasonably predict the ship roll response curve at the largest steepness by starting from the fitting of the roll response curve(s) experimentally obtained at lower steepnesses. The pure quadratic damping model allows for the achievement of good predictions of the experimental peak, probably thanks to the presence of bilge keels. In the case of linear+quadratic damping model, a negative linear damping coefficient has been obtained, that is, of course, physically meaningless. However, the equivalent linear damping in the range of tested angles as given by the fitted model in Calculation 3-LQ is, of course, positive. The negative sign in the linear damping coefficient is thus due to the fact that the equivalent linear damping obtained from the fitted model in the range of tested rolling amplitudes better fits the experimental data according to the minimization procedure. If a series of experiments had been carried out at smaller steepnesses with subsequent fitting, it would have increased the linear damping coefficient, making it, probably, positive. Bearing in mind the theoretical background of the PIT technique, negative linear damping coefficients are often not a real practical problem, even if their presence usually indicates that different types of analytical modelling for the damping function could lead to a better representation of the real ship damping.

**Table 6.1 Analytical models used in the fitting and fitted parameters (model scale)**

	Calculation 1	Calculation 2	Calculation 3-Q	Calculation 3-LQ
Steepness used in the fitting	1/60	1/40	1/60 and 1/40	
Analytical model	$\ddot{\phi} + \beta \cdot \dot{\phi} \cdot  \dot{\phi}  + \omega_0^2 \cdot \phi = \omega_0^2 \cdot \pi \cdot s \cdot \alpha_0 \cdot \cos(\omega \cdot t)$			$\ddot{\phi} + 2\mu \cdot \dot{\phi} + \beta \cdot \dot{\phi} \cdot  \dot{\phi}  + \omega_0^2 \cdot \phi = \omega_0^2 \cdot \pi \cdot s \cdot \alpha_0 \cdot \cos(\omega \cdot t)$
Fitted coefficients	$\omega_0 = 3.344 \text{ rad/s}$ $\beta = 0.520 \text{ rad}^{-1}$ $\alpha_0 = 0.873$	$\omega_0 = 3.348 \text{ rad/s}$ $\beta = 0.518 \text{ rad}^{-1}$ $\alpha_0 = 0.857$	$\omega_0 = 3.346 \text{ rad/s}$ $\beta = 0.519 \text{ rad}^{-1}$ $\alpha_0 = 0.864$	$\omega_0 = 3.345 \text{ rad/s}$ $\mu = -0.028$ $\omega_0$ $\beta = 0.684 \text{ rad}^{-1}$ $\alpha_0 = 0.833$
Predicted value in degrees of $\phi_{1r}$ for $s = 0.0383$	28.3	28.1	28.2	27.0
Corresponding value of $\phi_1 = 0.7 \cdot \phi_{1r}$	19.8	19.7	19.7	18.9
Experimentally determined $\phi_1$ in degrees	19.3			

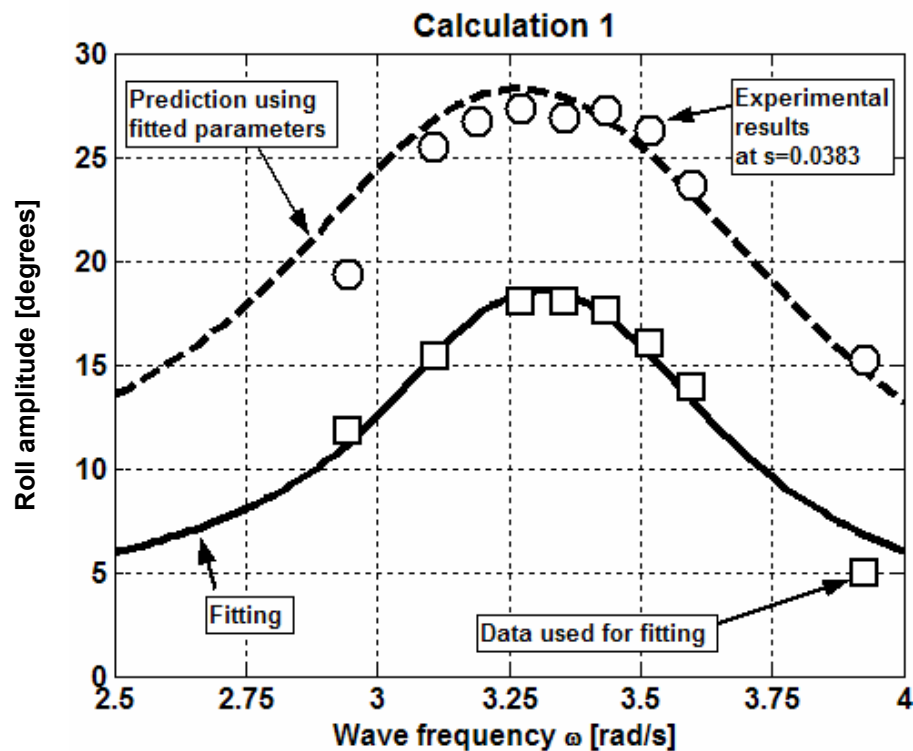

**Figure 6.3 Response curves for Calculation 1**

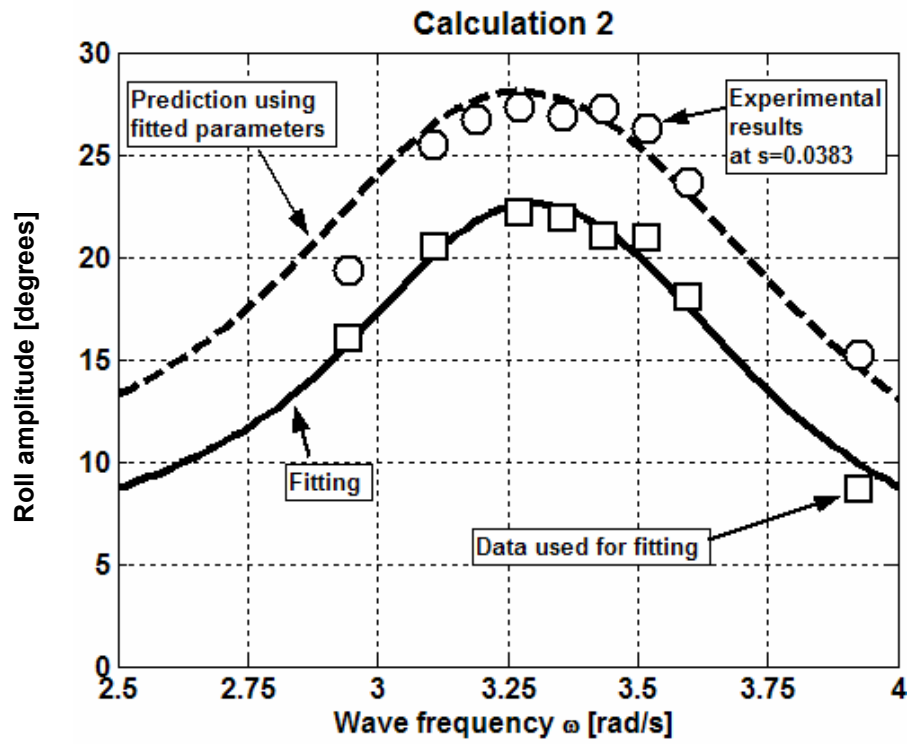

Figure 6.4 Response curves for Calculation 2

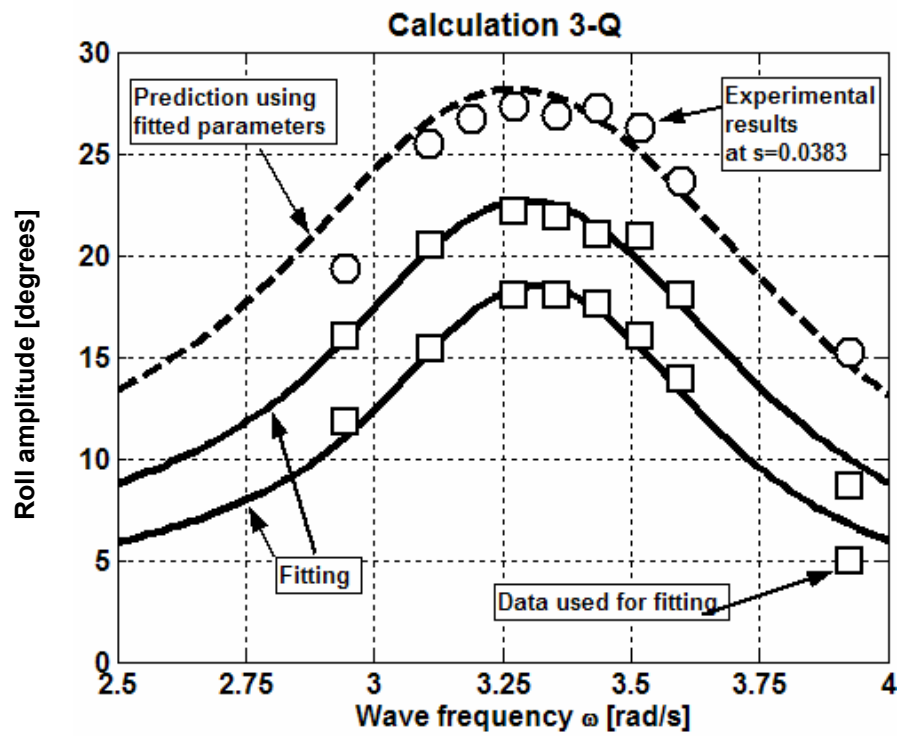

Figure 6.5 Response curves for Calculation 3-Q

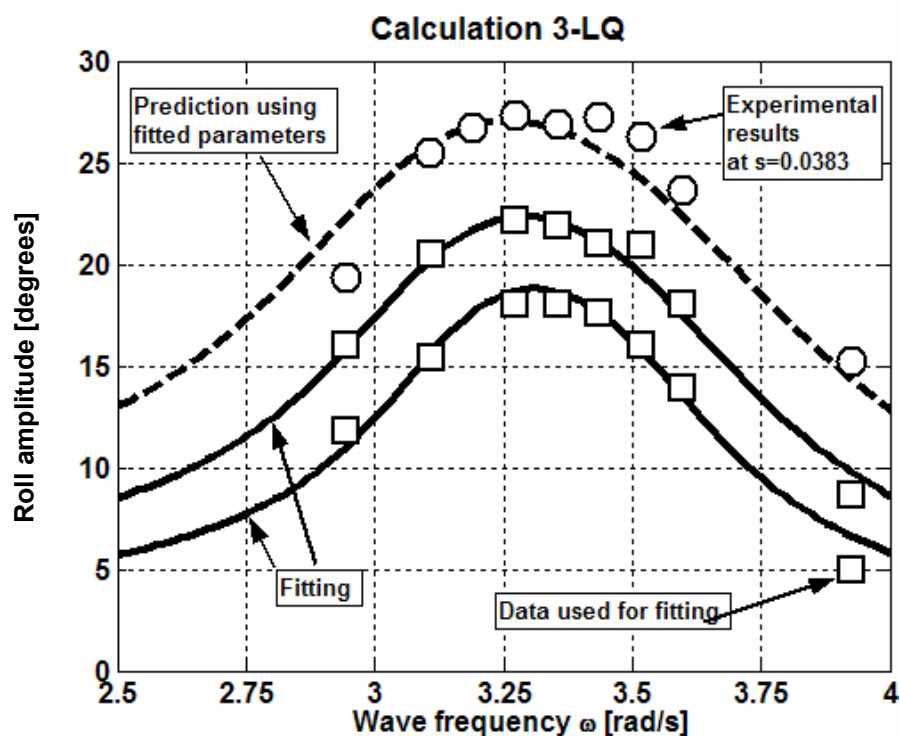

Figure 6.6 Response curves for Calculation 3-LQ

6.3.7 In order to better explain this latter point, an additional calculation (Calculation 3-LQC) has been carried out using experimental data for steepnesses  $s=1/60$  and  $s=1/40$  in the fitting procedure together with a more flexible linear+quadratic+cubic model for the damping, keeping the linear restoring assumption, i.e.:

$$\ddot{\phi} + 2\mu \cdot \dot{\phi} + \beta \cdot \dot{\phi} |\dot{\phi}| + \delta \cdot \dot{\phi}^3 + \omega_0^2 \cdot \phi = \omega_0^2 \cdot \pi \cdot s \cdot \alpha_0 \cdot \cos(\omega \cdot t) \quad (\text{N-6.4})$$

6.3.8 The obtained parameters are as follows:

$$\begin{aligned} \omega_0 &= 3.345 \text{ rad/s} \\ \frac{\mu}{\omega_0} &= 0.013 \\ \beta &= 0.126 \text{ rad}^{-1} \\ \delta \cdot \omega_0 &= 0.929 \text{ rad}^{-2} \\ \alpha_0 &= 0.844 \end{aligned}$$

6.3.9 It can be seen that now the negative linear damping has disappeared, and that the nonlinear damping component is distributed among the quadratic and cubic term. Although this result is more sound from a physical point of view, it is not necessarily the best one in terms of the predicted roll peak at  $s=0.0383$ . The predicted peak of the roll response is, indeed,  $\phi_{lr} = 26.6^\circ$  leading to  $\phi_1 = 18.6^\circ$ . The reduction in the predicted roll peak is likely due to the introduction of the cubic term. A summarizing plot is given in figure 6.7.

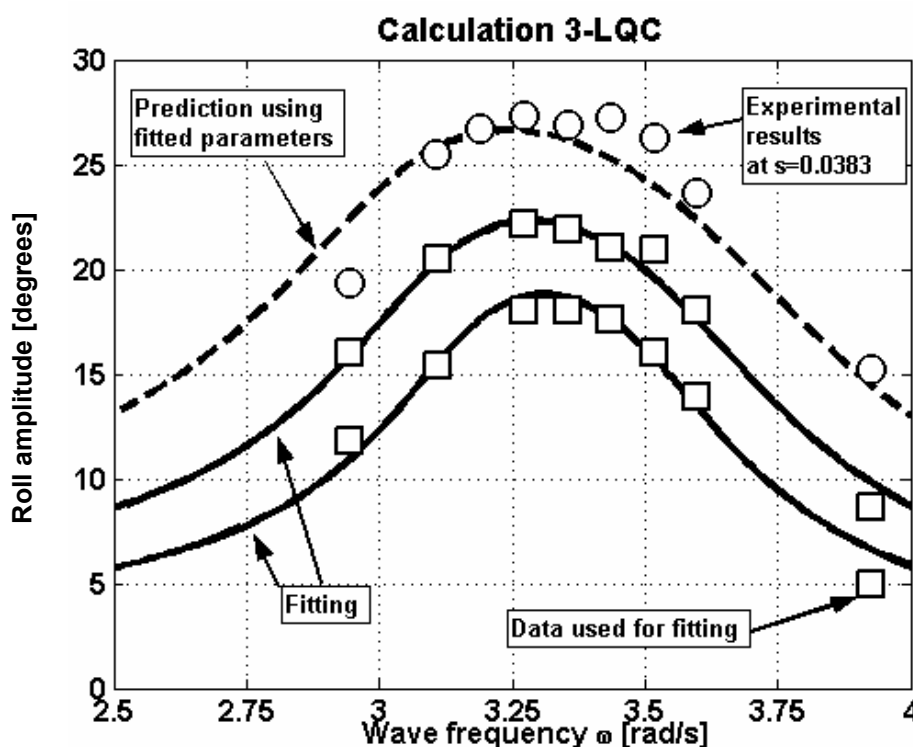

Figure 6.7 Response curves for Calculation 3-LQC

## 6.4 Final remarks

6.4.1 The PIT technique has successfully been applied to the experimental data used in the previous sections for the application of the Three Steps Procedure.

6.4.2 It can be concluded that, for the ship under analysis, a pure quadratic model for damping, together with a pure linear model for the restoring term is sufficient, for practical purposes, to predict the roll peak  $\phi_r$ , at the steepness required by the alternative assessment of Weather Criterion.

6.4.3 It is however important to underline that for ships having significant nonlinear  $\overline{GZ}$  curves, it is necessary to introduce a nonlinear correction in the restoring term in order to account for the bending of the response curve and the corresponding peak frequency shift. It is in addition noted, from the experience gained from this exercise, that an additional test in the range of low forcing frequencies (say  $\omega = 0.75 \cdot \omega_0$ ) could help in the fitting of the effective wave slope, allowing to take into account a frequency dependence of this coefficient. This latter frequency dependence could be important when the bending of the response curve is significant.

6.4.4 As an additional note, it can be said that the application of different tentative models in the PIT allows for an assessment of the likely level of uncertainty inherent in the extrapolation.

6.4.5 In the case under analysis, the level of uncertainty is of the order of  $\pm 2^\circ$ , however this figure strongly depends on the actual analysed case.

**6.4.6** The value of the effective wave slope obtained through the PIT (about 0.85 on average) is slightly different from the value obtained through the application of the Three steps procedure ( $r = 0.759$ ). This difference can be readily explained by recalling that, in the Three steps procedure, the damping is evaluated from the roll decays tests, while the effective wave slope is evaluated from the roll tests in beam waves, using the previously obtained damping coefficient. In the PIT approach, on the contrary, both the damping and the effective wave slope are determined from the same experimental data in beam waves, for this reason the final outcomes could differ in terms of single components. The final predictions of the angle  $\phi_r$ , given by the PIT technique and by the Three steps procedure are however very close: the two alternative procedures can be then considered, for this particular case, as equivalent from a practical point of view.

## **6.5 References**

- [1] Francescutto, A., Contento, G., “Bifurcations in Ship Rolling: Experimental Results and Parameter Identification Technique”, Ocean Engineering, Vol. 26, 1999, pp. 1095-1123.
- [2] Tzamtzis, S., Francescutto, A., Bulian, G. and Spyrou, K., “Development and testing of a procedure for the alternative assessment of Weather Criterion on experimental basis”, Technical Report, University of Trieste, Dept. Naval Architecture & Environmental Engineering, 2005.
- [3] Nayfeh, A.H., Mook, D.T., “Nonlinear Oscillations”, John Wiley & Sons, Inc., 1979.
- [4] IMO Document, SLF 47/6/18, “Proposal of Guidelines for a standard model test procedure to determine the steady wind heeling lever”, Submitted by Italy and Japan, 7 July 2004.
- [5] IMO Document, SLF 47/6/19, “Proposal of Guidelines for model tests to determine the roll angle for the weather criterion”, Submitted by Japan, 7 July 2004.
- [6] IMO Document, SLF 48/4/15, “Comments on draft guidelines for alternative assessment of weather criterion based on trial experiment results”, Submitted by Japan, 8 July 2005.

\*\*\*



**ANNEX 6****DRAFT MSC CIRCULAR****REVISED GUIDANCE TO THE MASTER FOR AVOIDING DANGEROUS SITUATIONS IN ADVERSE WEATHER AND SEA CONDITIONS**

1 The Maritime Safety Committee, at its [eighty-second session (29 November to 8 December 2006)], approved the Revised Guidance to the master for avoiding dangerous situations in adverse weather and sea conditions, set out in the annex, with a view to providing masters with a basis for decision making on ship handling in adverse weather and sea conditions, thus assisting them to avoid dangerous phenomena that they may encounter in such circumstances.

2 Member Governments are invited to bring the annexed Revised Guidance to the attention of interested parties as they deem appropriate.

3 This Revised Guidance supersedes the Guidance to the master for avoiding dangerous situations in following and quartering seas (MSC/Circ.707).

## ANNEX

### REVISED GUIDANCE TO THE MASTER FOR AVOIDING DANGEROUS SITUATIONS IN ADVERSE WEATHER AND SEA CONDITIONS

#### 1 GENERAL

1.1 Adverse weather conditions, for the purpose of the following guidelines, include wind induced waves or heavy swell. Some combinations of wave length and wave height under certain operation conditions may lead to dangerous situations for ships complying with the IS Code. However, description of adverse weather conditions below shall not preclude a ship master from taking reasonable action in less severe conditions if it appears necessary.

1.2 When sailing in adverse weather conditions, a ship is likely to encounter various kinds of dangerous phenomena, which may lead to capsizing or severe roll motions causing damage to cargo, equipment and persons on board. The sensitivity of a ship to dangerous phenomena will depend on the actual stability parameters, hull geometry, ship size and ship speed. This implies that the vulnerability to dangerous responses, including capsizing, and its probability of occurrence in a particular sea state may differ for each ship.

1.3 On ships which are equipped with an on-board computer for stability evaluations, and which use specially developed software which takes into account the main particulars, actual stability and dynamic characteristics of the individual ship in the real voyage conditions, such software should be approved by the Administration. Results derived from such calculations should only be regarded as a supporting tool during the decision making process.

1.4 Waves should be observed regularly. In particular, the wave period  $T_W$  should be measured by means of a stop watch as the time span between the generation of a foam patch by a breaking wave and its reappearance after passing the wave trough. The wave length  $\lambda$  is determined either by visual observation in comparison with the ship length or by reading the mean distance between successive wave crests on the radar images of waves.

1.5 The wave period and the wave length  $\lambda$  are related as follows:

$$\lambda = 1.56 \cdot T_W^2 \text{ [m]} \text{ or } T_W = 0.8\sqrt{\lambda} \text{ [s]}$$

1.6 The period of encounter  $T_E$  could be either measured as the period of pitching by using stop watch or calculated by the formula:

$$T_E = \frac{3T_W^2}{3T_W + V\cos(\alpha)} \text{ [s]}$$

where  $V$  = ship's speed [knots]; and

$\alpha$  = angle between keel direction and wave direction ( $\alpha = 0^\circ$  means head sea)

1.7 The diagram in figure 1 may as well be used for the determination of the period of encounter.

1.8 The height of significant waves should also be estimated.

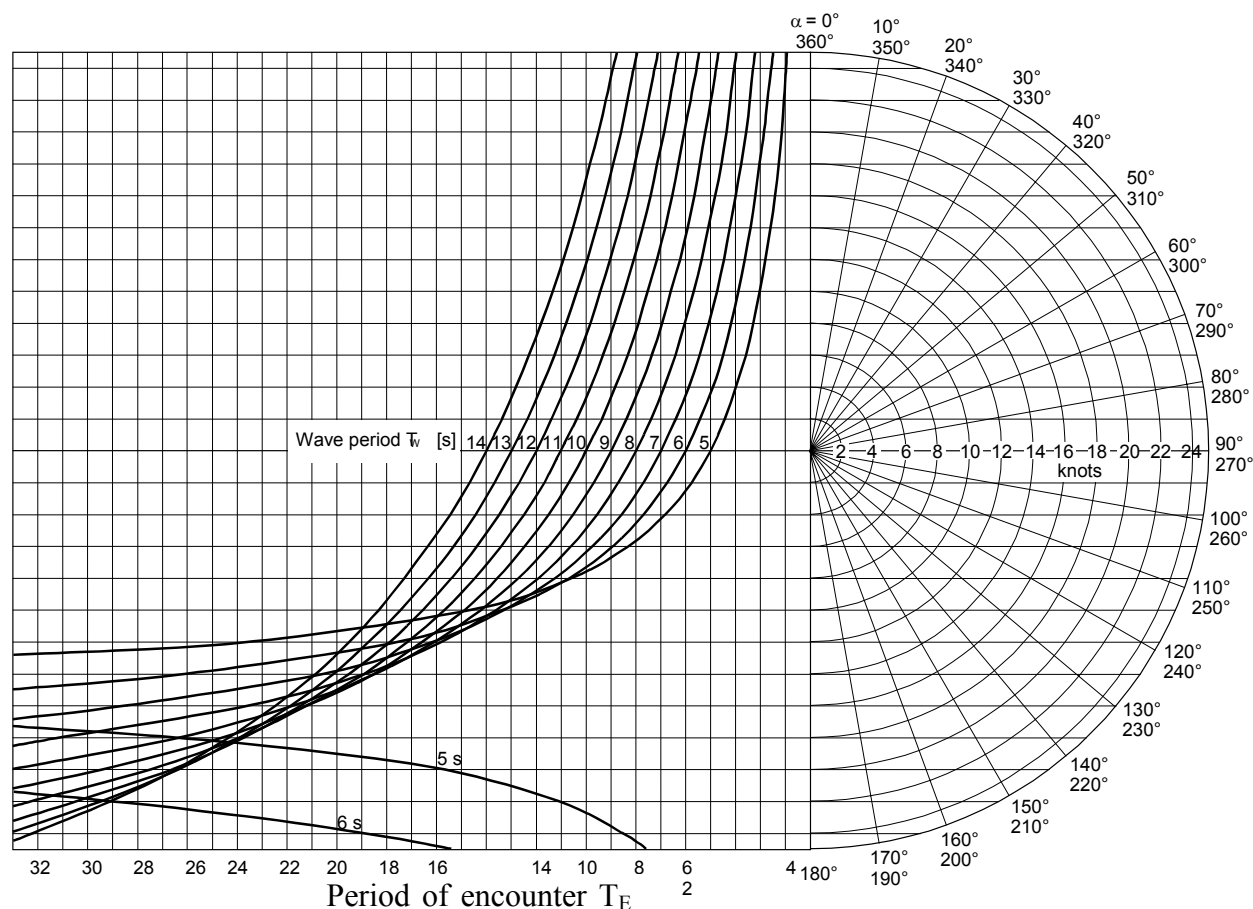

**Figure 1: Determination of the period of encounter  $T_E$**

## 2 CAUTIONS

2.1 It should be noted that this guidance to the master has been designed to accommodate for all types of merchant ships. Therefore, being of a general nature, the guidance may be too restrictive for certain ships with more favourable dynamic properties, or too generous for certain other ships. A ship could be unsafe even outside the dangerous zones defined in this guidance if the stability of the ship is insufficient. Masters are requested to use this guidance with fair observation of the particular features of the ship and her behaviour in heavy weather.

2.2 It should further be noted that this guidance is restricted to hazards in adverse weather conditions that may cause capsizing of the vessel or heavy rolling with a risk of damage. Other hazards and risks in adverse weather conditions, like damage through slamming, longitudinal or torsional stresses, special effects of waves in shallow water or current, risk of collision or stranding, are not addressed in this guidance and must be additionally considered when deciding on an appropriate course and speed in adverse weather conditions.

2.3 The master should ascertain that his ship complies with the stability criteria specified in the IS Code or an equivalent thereto. Appropriate measures should be taken to assure the ship's watertight integrity. Securing of cargo and equipment should be re-checked. The ship's natural period of roll  $T_R$  should be estimated by observing roll motions in calm sea.

### **3 DANGEROUS PHENOMENA**

#### **3.1 Phenomena occurring in following and quartering seas**

A ship sailing in following or stern quartering seas encounters the waves with a longer period than in beam, head or bow waves, and principal dangers caused in such situation are as follows:

##### ***3.1.1 Surf-riding and broaching-to***

When a ship is situated on the steep forefront of a high wave in following or quartering sea conditions, the ship can be accelerated to ride on the wave. This is known as surf-riding. In this situation the so-called broaching-to phenomenon may occur, which endangers the ship to capsizing as a result of a sudden change of the ship's heading and unexpected large heeling.

##### ***3.1.2 Reduction of intact stability when riding a wave crest amidships***

When a ship is riding on the wave crest, the intact stability can be decreased substantially according to changes of the submerged hull form. This stability reduction may become critical for wave lengths within the range of 0.6 L up to 2.3 L, where L is the ship's length in metres. Within this range the amount of stability reduction is nearly proportional to the wave height. This situation is particularly dangerous in following and quartering seas, because the duration of riding on the wave crest, which corresponds to the time interval of reduced stability, becomes longer.

#### **3.2 Synchronous rolling motion**

Large rolling motions may be excited when the natural rolling period of a ship coincides with the encounter wave period. In case of navigation in following and quartering seas this may happen when the transverse stability of the ship is marginal and therefore the natural roll period becomes longer.

#### **3.3 Parametric roll motions**

3.3.1 Parametric roll motions with large and dangerous roll amplitudes in waves are due to the variation of stability between the position on the wave crest and the position in the wave trough. Parametric rolling may occur in two different situations:

- .1 The stability varies with an encounter period  $T_E$  that is about equal to the roll period  $T_R$  of the ship (encounter ratio 1:1). The stability attains a minimum once during each roll period. This situation is characterized by asymmetric rolling, i.e. the amplitude with the wave crest amidships is much greater than the amplitude to the other side. Due to the tendency of retarded up-righting from the large amplitude, the roll period  $T_R$  may adapt to the encounter period to a certain extent, so that this kind of parametric rolling may occur with a wide bandwidth of encounter periods. In quartering seas a transition to harmonic resonance may become noticeable.
- .2 The stability varies with an encounter period  $T_E$  that is approximately equal to half the roll period  $T_R$  of the ship (encounter ratio 1:0.5). The stability attains a minimum twice during each roll period. In following or quartering seas, where the encounter period becomes larger than the wave period, this may only occur

with very large roll periods  $T_R$ , indicating a marginal intact stability. The result is symmetric rolling with large amplitudes, again with the tendency of adapting the ship response to the period of encounter due to reduction of stability on the wave crest. Parametric rolling with encounter ratio 1:0.5 may also occur in head and bow seas.

3.3.2 Other than in following or quartering seas, where the variation of stability is solely effected by the waves passing along the vessel, the frequently heavy heaving and/or pitching in head or bow seas may contribute to the magnitude of the stability variation, in particular due to the periodical immersion and emersion of the flared stern frames and bow flare of modern ships. This may lead to severe parametric roll motions even with small wave induced stability variations.

3.3.3 The ship's pitching and heaving periods usually equals the encounter period with the waves. How much the pitching motion contributes to the parametric roll motion depends on the timing (coupling) between the pitching and rolling motion.

### **3.4 Combination of various dangerous phenomena**

The dynamic behaviour of a ship in following and quartering seas is very complex. Ship motion is three-dimensional and various detrimental factors or dangerous phenomena like additional heeling moments due to deck-edge submerging, water shipping and trapping on deck or cargo shift due to large roll motions may occur in combination with the above mentioned phenomena, simultaneously or consecutively. This may create extremely dangerous combinations, which may cause ship capsize.

## **4 OPERATIONAL GUIDANCE**

The shipmaster is recommended to take the following procedures of ship handling to avoid the dangerous situations when navigating in severe weather conditions.

### **4.1 Ship condition**

This guidance is applicable to all types of conventional ships navigating in rough seas, provided the stability criteria specified in resolution A.749(18), as amended by resolution MSC.75(69), are satisfied.

### **4.2 How to avoid dangerous conditions**

#### **4.2.1 For surf-riding and broaching-to**

Surf-riding and broaching-to may occur when the angle of encounter is in the range  $135^\circ < \alpha < 225^\circ$  and the ship speed is higher than  $(1.8\sqrt{L})/\cos(180 - \alpha)$  (knots). To avoid surf riding, and possible broaching the ship speed, the course or both should be taken outside the dangerous region reported in figure 2.

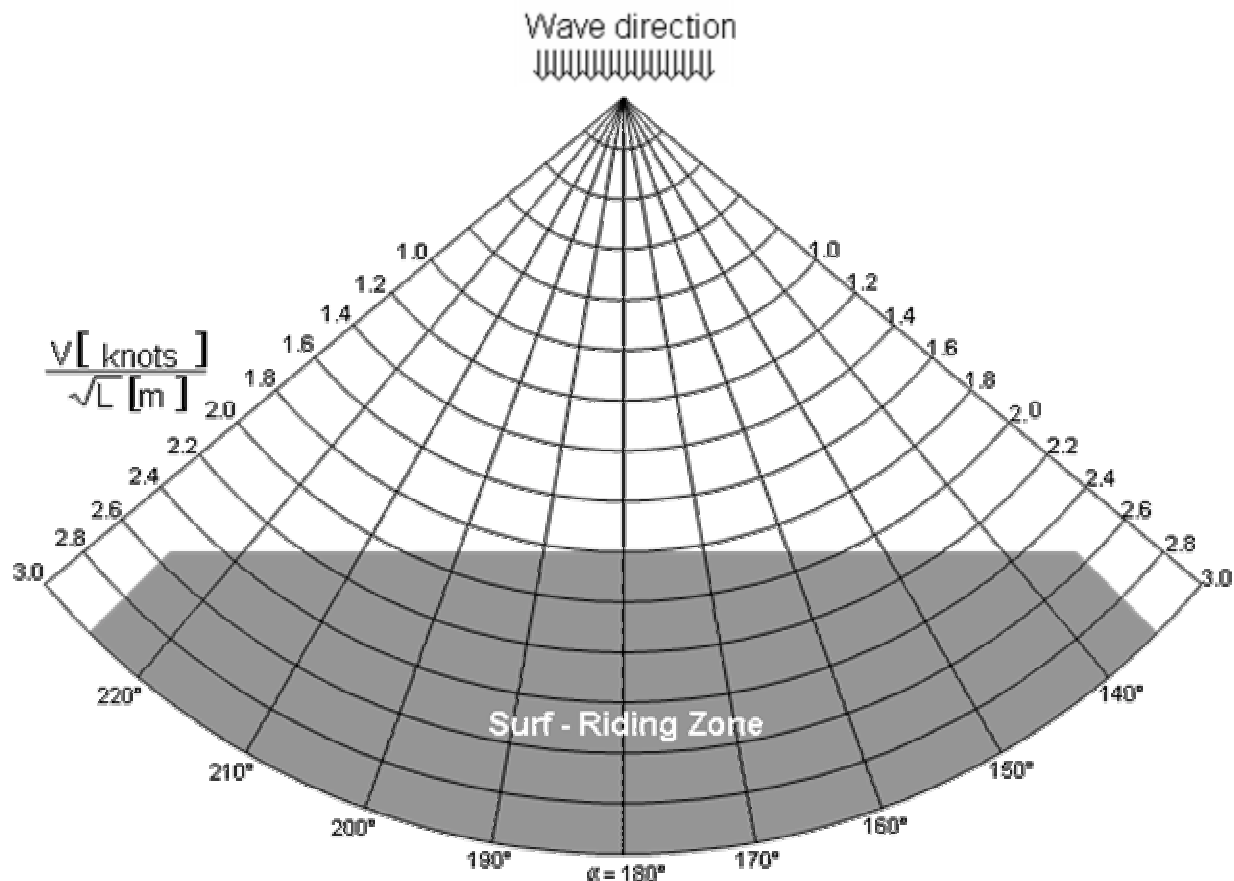

**Figure 2: Risk of surf-riding in following or quartering seas**

#### **4.2.2 For successive high-wave attack**

4.2.2.1 When the average wave length is larger than  $0.8 L$  and the significant wave height is larger than  $0.04 L$ , and at the same time some indices of dangerous behaviour of the ship can be clearly seen, the master should pay attention not to enter in the dangerous zone as indicated in figure 3. When the ship is situated in this dangerous zone, the ship speed should be reduced or the ship course should be changed to prevent successive attack of high waves, which could induce the danger due to the reduction of intact stability, synchronous rolling motions, parametric rolling motions or combination of various phenomena.

4.2.2.2 The dangerous zone indicated in figure 3 corresponds to such conditions for which the encounter wave period ( $T_E$ ) is nearly equal to double (i.e., about 1.8-3.0 times) of the wave period ( $T_W$ ) (according to figure 1 or paragraph 1.4).

#### **4.2.3 For synchronous rolling and parametric rolling motions**

4.2.3.1 The master should prevent a synchronous rolling motion which will occur when the encounter wave period  $T_E$  is nearly equal to the natural rolling period of ship  $T_R$ .

4.2.3.2 For avoiding parametric rolling in following, quartering, head, bow or beam seas the course and speed of the ship should be selected in a way to avoid conditions for which the

encounter period is close to the ship roll period ( $T_E \approx T_R$ ) or the encounter period is close to one half of the ship roll period ( $T_E \approx 0.5 \cdot T_R$ ).

4.2.3.3 The period of encounter  $T_E$  may be determined from figure 1 by entering with the ship's speed in knots, the encounter angle  $\alpha$  and the wave period  $T_W$ .

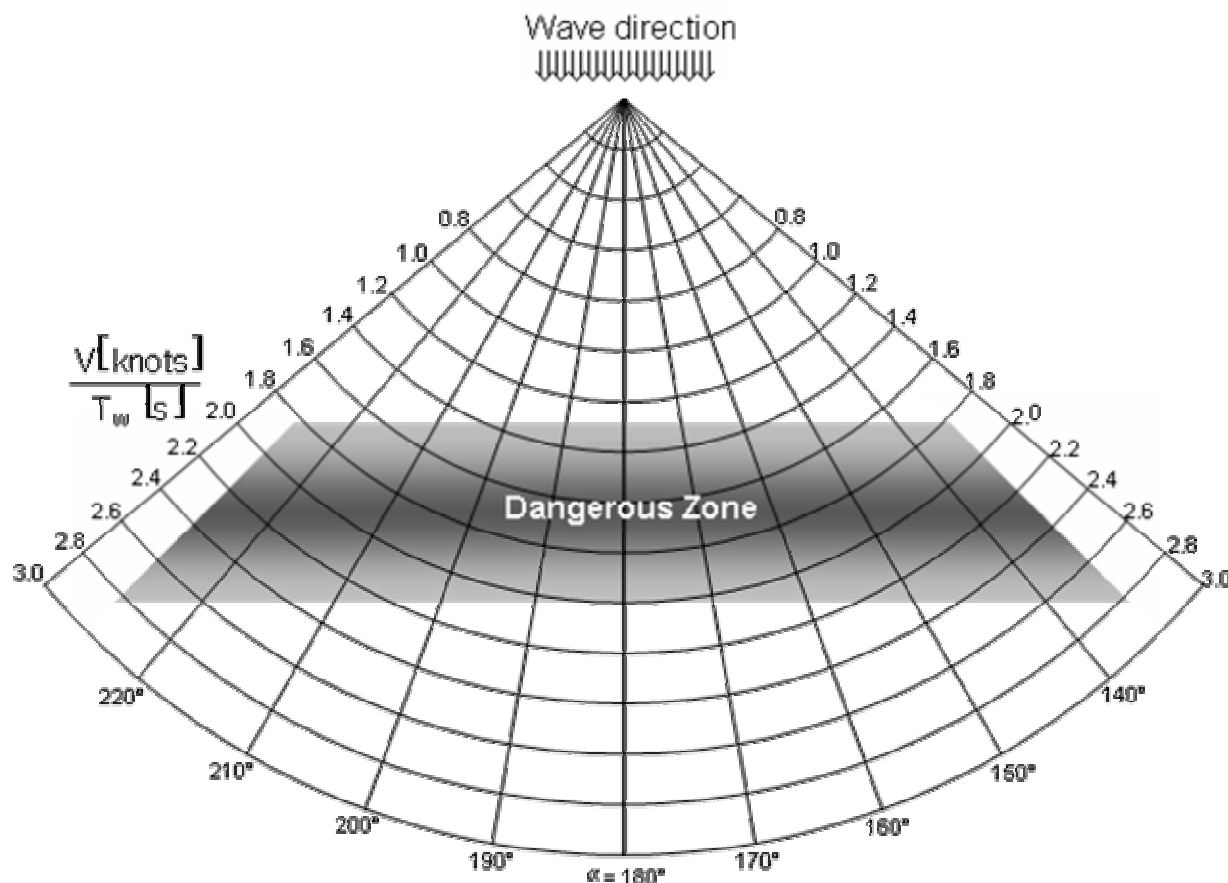

**Figure 3: Risk of successive high wave attack in following and quartering seas**

### Abbreviations and symbols

Symbols	Explanation	Units
$T_W$	wave period	s
$\lambda$	wave length	m
$T_E$	encounter period with waves	s
$\alpha$	angle of encounter ( $\alpha = 0^\circ$ in head sea, $\alpha = 90^\circ$ for sea from starboard side)	degrees
$V$	ship's speed	knots
$T_R$	natural period of roll of ship	s
$L$	length of ship (between perpendiculars)	m

\*\*\*





**ANNEX 7**

**DRAFT MSC CIRCULAR**

**GUIDELINES FOR THE APPROVAL OF STABILITY INSTRUMENTS**

1 The Maritime Safety Committee, at its [eighty-second session (29 November to 8 December 2006)], approved the Guidelines for the approval of stability instruments, set out in the annex, aiming at providing additional guidance on approval procedures of stability instruments supporting the safe operation of ships.

2 Member Governments are invited to bring the annexed Guidelines for the approval of stability instruments to the attention of interested parties as they deem appropriate.

## ANNEX

### GUIDELINES FOR THE APPROVAL OF STABILITY INSTRUMENTS

#### 1 Purpose

The aim of this document is to provide additional guidance on approval procedures of stability instruments supporting the safe operation of ships.

#### 2 Definition

A *stability instrument* is an instrument installed on board a particular ship by means of which it can be ascertained that stability requirements specified for the ship in Stability Booklet are met in any operational loading condition. A stability instrument comprises hardware and software.

#### 3 Software approval

The accuracy of the computational results and actual ship data used by the programs should be verified for the particular ship on which the programs will be installed. This ship specific approval of on-board loading instruments is required for all ships equipped with a stability instrument.

#### 4 Acceptable tolerances

4.1 Depending on the type and scope of programs, the acceptable tolerances should be determined differently, according to 4.1 or 4.2. Excess from these tolerances should not be accepted unless the Administration considers that there is a satisfactory explanation for the difference and that there will be no adverse effect on the safety of the ship.

4.2 Examples of pre-programmed input data include the following:

- .1 Hydrostatic data: displacement, LCB, LCF, VCB,  $KM_t$  and MCT versus draught.
- .2 Stability data: KN or MS values at appropriate heel/trim angles versus displacement, stability limits.
- .3 Compartment data: volume, LCG, VCG, TCG and FSM/grain heeling moments versus level of the compartment's contents.

4.3 Examples of output data include the following:

- .1 Hydrostatic data: displacement, LCB, LCF, VCB,  $KM_t$  and MCT versus draught as well as actual draughts, trim.
- .2 Stability data: FSC (free surface correction), GZ-values, VCG, GM, VCG/GM limits, allowable grain heeling moments, derived stability criteria, e.g. areas under the GZ curve, weather criteria.
- .3 Compartment data: calculated volume, LCG, VCG, TCG and FSM/grain heeling moments versus level of the compartment's contents.

4.4 The computational accuracy of the calculation program results should be within the acceptable tolerances specified in 4.1 or 4.2, of the results using an independent program or the approved stability information with identical input.

4.5 Programs which use only pre-programmed data from the approved stability information as the basis for stability calculations should have zero tolerances for the printouts of input data. Output data tolerances should be close to zero, however, small differences associated with calculation rounding or abridged input data are acceptable. Additionally differences associated with the use of hydrostatic and stability data for trims that differ from those in the approved stability information are acceptable subject to review by the Administration.

4.6 Programs which use hull form models as their basis for stability calculations may have tolerances for the printouts of basic calculated data established against either data from the approved stability information or data obtained using the authority's approval model. Acceptable tolerances should be in accordance with the table below.

<b>Hull Form Dependent</b>	
Displacement	2%
Longitudinal center of buoyancy, from AP	1% / 50 cm max
Vertical center of buoyancy	1% / 5 cm max
Transverse center of buoyancy	0.5% of B / 5 cm max
Longitudinal center of flotation, from AP	1% / 50 cm max
Moment to trim 1 cm	2%
Transverse metacentric height	1% / 5 cm max
Longitudinal metacentric height	1% / 50cm max
Cross curves of stability	50mm
<b>Compartment dependent</b>	
Volume or deadweight	2%
Longitudinal center of gravity, from AP	1% / 50 cm max
Vertical centre of gravity	1% / 5 cm max
Transverse center of gravity	0.5% of B / 5 cm max
Free surface moment	2%
Shifting moment	5%
Level of contents	2%
<b>Trim and stability</b>	
Draughts (forward, aft, mean)	1% / 5 cm max
GMt	1% / 5 cm max
GZ values	5% / 5 cm max
FS correction	2%
Downflooding angle	2°
Equilibrium angles	1°
Distance to unprotected openings or margin line from WL, if applicable	+/- 5% / 50 mm
Areas under righting arm curve	5% or 0,0012mrad

Deviation in % =  $\{(base\ value - applicant's\ value) / base\ value\} \times 100$

4.7 The “base value” may be taken from the approved stability information.

\*\*\*



**ANNEX 8****UPDATED PLAN OF ACTION FOR THE INTACT STABILITY WORK**

1 The following updated plan of action was agreed by the Sub-Committee, taking into account annex 3 of document SLF 48/WP.2 and the various tasks accomplished to date under this item.

2 The following remaining tasks are to be completed by 2007:

- .1 development of the performance-based criteria;
- .2 consideration of regulations for certain types of ships;
- .3 consideration of matters related to manoeuvrability and course keeping ability as they affect stability;
- .4 consideration of matters related to large accelerations and loads on cargo;
- .5 consideration of stability under dead ship condition;
- .6 consideration of matters related to stability variation in waves; and
- .7 consideration of matters related to direct assessment as an alternative.

\*\*\*



**ANNEX 9**

**DRAT AMENDMENTS TO THE INTERNATIONAL CODE FOR THE SAFE  
CARRIAGE OF PACKAGED IRRADIATED NUCLEAR FUEL, PLUTONIUM AND  
HIGH-LEVEL RADIOACTIVE WASTES ON BOARD SHIPS (INF CODE)**

**CHAPTER 2  
DAMAGE STABILITY**

- 1 In paragraph 2.2.1, the words “Part B” are replaced by the words “Part B-1”.
- 2 In paragraphs 2.2.2 and 2.3.2, the following new sentence is added at the end of the paragraphs:

“For ships less than 80 m in length, the subdivision index R at 80 m shall be used.”

\*\*\*





**ANNEX 10****DRAFT MSC RESOLUTION****RECOMMENDATIONS CONCERNING TONNAGE MEASUREMENT OF  
OPEN-TOP CONTAINERSHIPS**

THE MARITIME SAFETY COMMITTEE,

RECALLING Article 28(b) of the Convention on the International Maritime Organization concerning the functions of the Committee,

RECALLING FURTHER the relevant provisions of the International Convention on Tonnage Measurement of Ships, 1969,

RECALLING ALSO circular TM.5/Circ.4 on Provisional formula to calculate a reduced gross tonnage of Open-top containerships whereby the Committee, being concerned with the economic disadvantages caused by the use of greater gross tonnage in comparison with gross tonnage of conventional containerships for the assessment of fees, agreed to recommend a reduced gross tonnage for open-top containerships based on a provisional formula,

RECALLING ALSO circular TM.5/Circ.5 on Interpretations of the provisions of the International Convention on Tonnage Measurement of Ships, 1969, in particular section 3 entitled "Open-top containerships",

NOTING that, by the aforementioned circular TM.5/Circ.4, Governments were invited to submit to the Organization information on open-top containerships in operation and under consideration which would enable the assessment of the final coefficients in the formula, including principal dimensions, gross tonnage underdeck and ondeck carrying capacities of containers, deadweight etc.,

HAVING RECOGNIZED that based on the provisions included in circular MSC/Circ.608/Rev.1, open-top containerships are designed and constructed to a high safety level in particular. This applies to improved protection and securing of containers,

NOTING that, in view of the explicit amendment procedure of the 1969 Tonnage Measurement Convention, it may require a significant period of time for any amendment to become effective,

REALIZING the need for the establishment of the principles for the treatment and unified application of tonnage measurement of open-top containerships,

HAVING CONSIDERED, at its [eighty-second session], the recommendation made by the Sub-Committee on Stability and Load Lines and on Fishing Vessels Safety, at its forty-ninth session,

1. ADOPTS the Recommendations concerning tonnage measurement of open-top containerships, the text of which is set out in the Annex to the present resolution;

2. AGREES that Governments which are Contracting Governments to the 1969 Tonnage Measurement Convention should use these Recommendations when applying the provisions of the Convention;
3. INVITES Governments to advise the ports and harbours authorities to apply the Recommendations when assessing fees based on reduced gross tonnage for open-top containerships;
4. REVOKES circular TM.5/Circ.4 and section 3 entitled “Open-top containerships” of circular TM.5/Circ.5.

## ANNEX

### RECOMMENDATIONS CONCERNING TONNAGE MEASUREMENT OF OPEN-TOP CONTAINERSHIPS

1 In order to use a unified base for the application of tonnage measurement of open-top containerships, the Administrations are recommended to accept the following.

#### **Definition of open-top containership**

2 *An open-top containership*, for the purpose of application of the 1969 Tonnage Convention, means a ship which is designed for the carriage of containers and which is constructed like an open “U”, with not less than 66.7% of the cargo hatches in an “open-top” configuration, with a double bottom and above this, high-sided erections without hatch covers on the upper deck and without a complete deck above the moulded draught (refer to the figure), and needs to be regarded as a ship of a novel type as referred to in regulation 1(3).

#### **Interpretations of the provisions of the 1969 Tonnage Convention**

3 The provisions of the 1969 Tonnage Convention for treatment of enclosed spaces should be applied to open-top containerships subject to the following unified interpretations:

.1 ***Upper deck (regulation 2(1))***

In a ship which is exempted by the Administration from the requirements to fit weathertight hatch covers on the uppermost deck exposed to weather and sea, as in an open-top containership, the upper deck should be taken as that deck which would have been determined by regulation 2(1) as if such hatch covers had been fitted.

.2 ***Enclosed spaces (regulation 2(4))***

In open-top containerships, an opening in a deck such as the absence of hatch covers should not preclude a space from being included in the enclosed space.

.3 ***Shelter above container stacks***

In the case of open-top containerships having movable non-load-bearing covers (shelter) of light construction resting on the container-guides, the space above the hatch coamings up to the covers does not qualify as an excluded space according to regulation 2(5). For this particular design, however, an exception can be made in accordance with regulation 1(3). The space can be excluded provided that this type of ship meets the requirements of an open-top containership without such covers.

### Reduced gross tonnage of open-top containerships

4 To reduce the disadvantages caused by the use of a greater gross tonnage in comparison with a gross tonnage of conventional containerships for assessing fees, a reduced gross tonnage for open-top containerships, without limitation in size, based on a simplified formula is recommended as follows:

$$GT_R = 0.9 \times GT$$

where:

$GT_R$  = the reduced gross tonnage

$GT$  = the gross tonnage calculated in accordance with the 1969 Tonnage Convention

### Entry into the International Tonnage Certificate (1969)

5 In the International Tonnage Certificate (1969), under “Remarks”, an entry should be made for the tonnage of the open-top containership as follows:

“In accordance with resolution MSC. ... (82), the reduced gross tonnage which should be used for the calculation of tonnage-based fees is.....”

### Figure referred to in paragraph 2

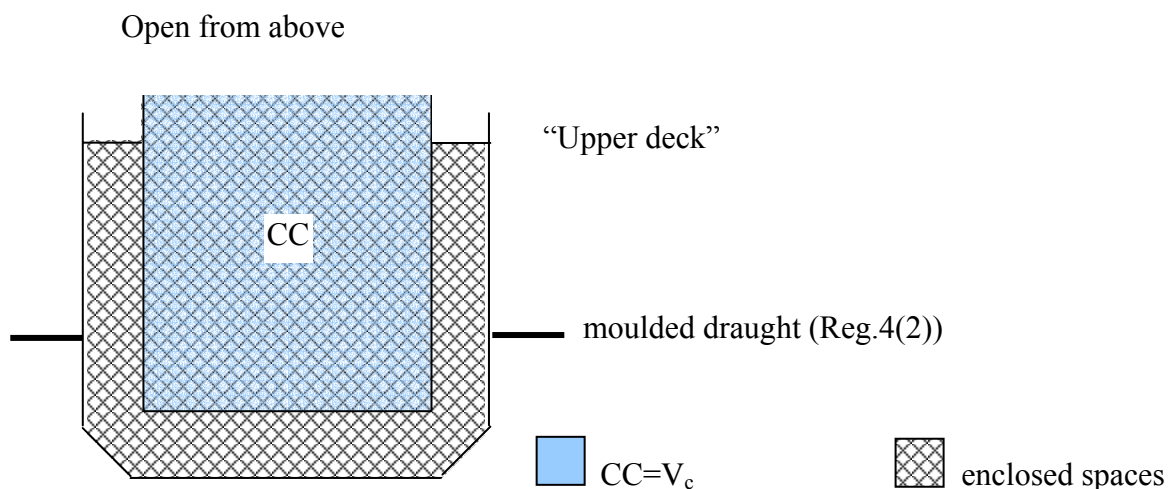

\*\*\*

ANNEX 11

DRAFT REVISED FORM OF DAMAGE CARD  
INTERNATIONAL MARITIME ORGANIZATION

Card No ..... Number of files to this casualty .....  
(If more than one damage, please complete another sheet with description of that penetration)

Date and place° of casualty (category and details) .....  
(harbour, quay wall ; river, channel ; coastal waters ; open sea ; other)

Nature of casualty (category and details) .....  
(capsize ; collision ; fire/explosion ; grounding ; heavy weather ; loss ; other)

Nature of damage (category and details) .....  
(dent/deformation ; breakage/crevice ; strong deformation ; other)

Damaged Ship.

Ship Name° ..... IMO No. ....

Type\* (category and details) .....  
(Bulk Carrier ; Gen. Cargo ; Container ; Fishing ; Passenger + Pass/Cargo ; RoRo, Car Carrier, Ferry, Car Ferry ; Service Ship + Specialised ; Tanker ; other)

Length between perpendiculars\*  $L_{pp}$  = .....  $L_{oa}$  = ..... Moulded breadth\*  $B$  = .....

Moulded depth\*  $D$  = .....

Draught before damage: amidships  $d_i$  = ..... (or fore  $d_i$  = ..... aft  $d_i$  = .....)

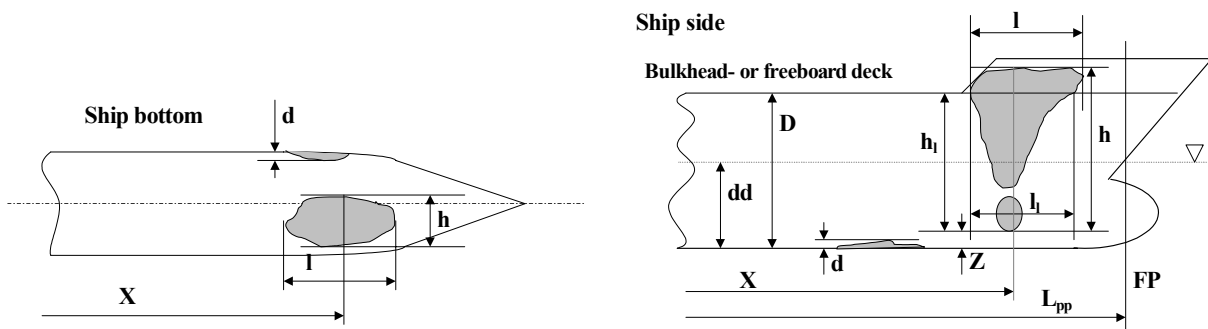

Dimensions and location of damage (see sketches above).

Ship side ..... Damage position .....  
(portside ; starboard ; bottom) (fore ship ; afterbody ; cargohold ; rudder ; engineroom ; other)

Position (height) with reference to WL ..... Damage type (position No) .....  
(damage extends: 1=below and above; 2=above but not below; 3= below but not above; 4= within - the physical limits of the ship structure)

Distance from AP to centre of damage\*  $X$  = .....

Distance from base line to the lower point of damage\*  $Z$  = .....

Length of  $l$  = ..... Height of  $h$  = ..... Penetration  $d$  = .....

damage\*  $l_1$  = ..... damage\*  $h_1$  = ..... of damage\*  $d_1$  = .....

$dd_{mid}$  = .....  $dd_{fore}$  = .....  $dd_{aft}$  = ..... (draughts after damage)

$dd_{mid\ calc}$  = .....

Hole in ship:  Yes  No

Struck vessel:  Yes  No

Ship to ship collision:  Yes  No

Striking vessel:  Yes  No

Notes: .....

(If damage extends above bulkhead/freeboard deck, additional dimensions should be given for the part located below this deck, these being marked with suffix "1")



**NOTES**

1. Damage cards should be completed for decked, steel seagoing ships 25 m in length and over, for all breaches of the hull causing flooding of any compartment (collisions, stranding, etc.)
2. The term "damaged ship" refers to the ship for which this card is being completed.
3. A sketch showing location of damage and of main transverse bulkheads would be desirable.
4. Depth D should be measured to the bulkhead deck in passenger ships and to the freeboard deck in non-passenger ships or to the uppermost completed deck, if bulkhead or freeboard deck are not specified.
5. In the case of collision with another ship, it is desirable to fill in damage cards for both ships.
6. All measurements should be given in metres.
7. Data marked with an asterisk (\*) are the most important.
8. The provision of data marked (°) is optional.

\*\*\*





## ANNEX 12

**PROPOSED REVISED WORK PROGRAMME OF THE SUB-COMMITTEE  
AND PROVISIONAL AGENDA FOR SLF 50**

**PROPOSED REVISED WORK PROGRAMME OF THE SUB-COMMITTEE**

		<b>Target completion date/number of sessions needed for completion</b>	<b>Reference</b>
1	Analysis of intact stability casualty records	Continuous	MSC 70/23, paragraph 20.4; SLF 30/18, paragraphs 4.16 and 4.17
2	<b>Analysis of damage cards</b>	Continuous	MSC 70/23, paragraph 20.4;
	<del>±</del> <b>revision of the IMO damage card</b>	2006	<del>SLF 41/18, paragraph 17.5; MSC 78/26, paragraph 12.10; SLF 48/21, section 15</del>
3	<b>Consideration of IACS unified interpretations</b>	Continuous	MSC 78/26, paragraph 22.12
H.1	<b>Development of explanatory notes for harmonized SOLAS chapter II-1</b>	<del>2006</del> 2008	MSC 69/22, paragraph 20.60.1; <del>SLF 48/21, section 3</del> SLF 49/17, section 3
H.2	<b>Safety of small fishing vessels</b> (in co-operation with DE, COMSAR, FP, NAV and STW, as necessary)	2009	MSC 79/23, paragraphs 11.15 and 20.32; SLF 48/21, section 16

- 
- Notes:**
- "H" means a high priority item and "L" means a low priority item. However, within the high and low priority groups, items have not been listed in any order of priority.
  - Struck-out text indicates proposed deletions and the shaded text shows proposed additions or changes.
  - Items printed in bold letters have been selected for inclusion in the provisional agenda for SLF 50.

**Work programme of the Sub-Committee (continued)**

		<b>Target completion date/number of sessions needed for completion</b>	<b>Reference</b>
H.3	<b>Passenger ship safety</b>	2006	MSC 74/24, paragraph 21.4; SLF 48/21, section 6
H.4 H.3	<b>Revision of the Intact Stability Code</b>	2007	SLF 41/18, paragraph 3.14; SLF 48/21, section 4 SLF 49/17, section 5
H.5 H.4	<b>Review of the SPS Code (co-ordinated by DE)</b>	2006 2007	MSC 78/26, paragraph 24.9 SLF 49/17, section 11
H.6 H.5	<b>Development of options to improve effect on ship design and safety of the 1969 TM Convention</b>	2008	MSC 81/25, paragraph 23.53
H.7 H.6	<b>Guidelines for uniform operating limitations on high-speed craft (co-ordinated by DE)</b>	2008	MSC 81/25, paragraph 23.45
H.8 H.7	<b>Time dependant survivability of passenger ships in damaged condition</b>	3 sessions 2009	MSC 81/25, paragraph 23.54 SLF 49/17, section 14
[H.8]	<b>Interpretation of alterations and modifications of a major character under the revised SOLAS chapter II-1</b>	2007	SLF 49/17, section 13]*
[H.9]	<b>Guidance on the impact of open watertight doors on survivability under regulation 22.4 of the revised SOLAS chapter II-1</b>	2008	SLF 49/17, section 13]*

---

\* Pending approval of MSC 82.

Work programme of the Sub-Committee (continued)

		<b>Target completion date/number of sessions needed for completion</b>	<b>Reference</b>
<del>L.2</del> L.1	<b>Revision of resolution A.266(VIII)</b>	<del>2006</del> 2007	SLF 45/14, paragraphs 3.19 and 11.1.4.1; MSC 76/23, paragraph 20.50; SLF 47/17, paragraph 14.2 SLF 49/17, section 9
L.3	<b>Tonnage measurement of open-top containerhips</b>	2006	MSC 78/26, paragraph 24.50; SLF 47/17, paragraph 14.2
<del>L.4</del> L.2	<b>Revision of MSC/Circ.650</b>	<del>2006</del> 2007	SLF 47/17, paragraph 3.8 SLF 49/17, section 13

**DRAFT PROVISIONAL AGENDA FOR SLF 50\***

- Opening of the session
- 1 Adoption of the agenda
  - 2 Decisions of other IMO bodies
  - 3 Development of explanatory notes for harmonized SOLAS chapter II-1
  - 4 Revision of the Intact Stability Code
  - 5 Safety of small fishing vessels
  - 6 Development of options to improve effect on ship design and safety of the 1969 TM Convention
  - 7 Guidelines for uniform operating limitations on high-speed craft
  - 8 Time dependant survivability of passenger ships in damaged condition
  - 9 Consideration of IACS unified interpretations
  - 10 Revision of resolution A.266(VIII)
  - 11 Review of the SPS Code
  - 12 Analysis of damage cards
  - 13 Revision of MSC/Circ.650
  - [14 Interpretation of alterations and modifications of a major character under the revised SOLAS chapter II-1]\*\*
  - [15 Guidance on the impact of open watertight doors on survivability under regulation 22.4 of the revised SOLAS chapter II-1]\*\*
  - 16 Work programme and agenda for SLF 51
  - 17 Election of Chairman and Vice-Chairman for 2008
  - 18 Any other business
  - 19 Report to the Maritime Safety Committee

---

\* Agenda item numbers do not necessarily indicate priority.

\*\* Pending approval of MSC 82.